

RESTRICTED

CHAPTER 9
FITS, CLEARANCES AND
REPAIR TOLERANCES

CHAPTER 9

A.P. 4308, Vol. 6, Part 1
A.L.B., Feb. 61

6

CHAP.

Chapter 9

FITS, CLEARANCES AND REPAIR TOLERANCES

List of contents

Para.	1	Introduction ...
	2	Method of using tables
	3	Fitting of bushes
Para.	4	Oversize pins and bolts
	5	Ballraces and needle bearings

List of illustrations

Fig.	9/1	Engine mounting, fuselage and tailplane attachment
	9/2	Aligning gear
Fig.	9/3	Wing

Introduction
 1. This chapter gives tables of permissible limits of wear for male and female parts of various joints, together with the methods of rectification when such limits are exceeded. Each table faces an exploded view in which the parts are referenced by Key Numbers for easy identification.

Method of using tables
 2. First identify the item to be checked on the appropriate illustration and the associated table, by means of its Key No. Then check the diameter of the item by micrometer or plug gauge as instructed in the table. If the "Max. wear diameter" is not exceeded the item is suitable for a further period of service; when the specified plug gauge can be inserted in a female part, or the micrometer reading for a male part indicates a diameter less than quoted in the table, rectification action must be taken as follows:

Bushed holes - Renew the bush or fit an oversize bush. Part No. and remaining diameter are specified and reaming diameter are specified.

(a) Ream the hole in the fitting to the dimensions quoted in the last column of the table
 (b) Press in the oversize bush, first applying Duralac where the metals are dissimilar
 (c) Ream the oversize bush to the "As new" diameter quoted in the sixth column of the table
 (d) Drill oil holes from grease nipples, etc. through the bush and check that they are clear

RESTRICTED

races or tracks are firm in their housing and are free from pitting, flaking or dents. Bearings must rotate freely under finger pressure, and needles should not skew or seize. If any of these faults occur, the affected bearings must be renewed. Note...

Side play in ball bearings, particularly those of "self aligning" type, should not be confused with diametrical wear.

4. In order to preserve interchangeability, no oversize pins or bolts are issued for general use on Chipmunk aircraft. Should it be found expedient to fit an oversize item, application for a special repair scheme can be made.

Ballraces and needle bearings

5. Check that the inner and outer

RESTRICTED

Continued overleaf

A.P.4308, Vol.6, Part 1, Chap.9
A.L.8, Feb.61

F.S./2

Fig. 9/1. Engine mounting, fuselage and tailplane attachments.

ENGINE MOUNTING

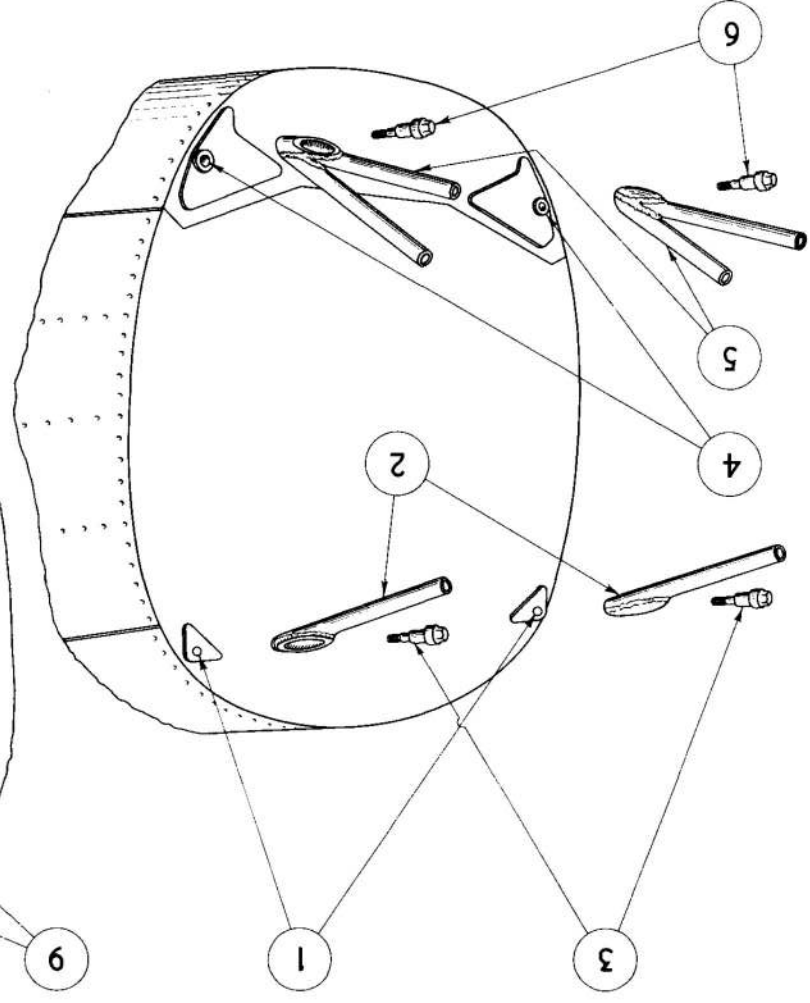

RUDDER CONNECTING BAR ATTACHMENTS

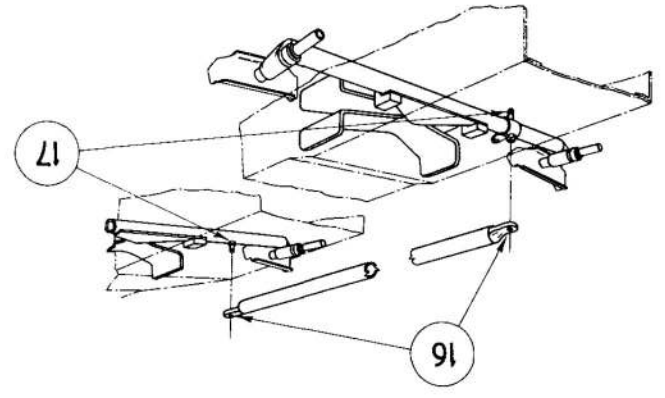

TAILPLANE ATTACHMENTS

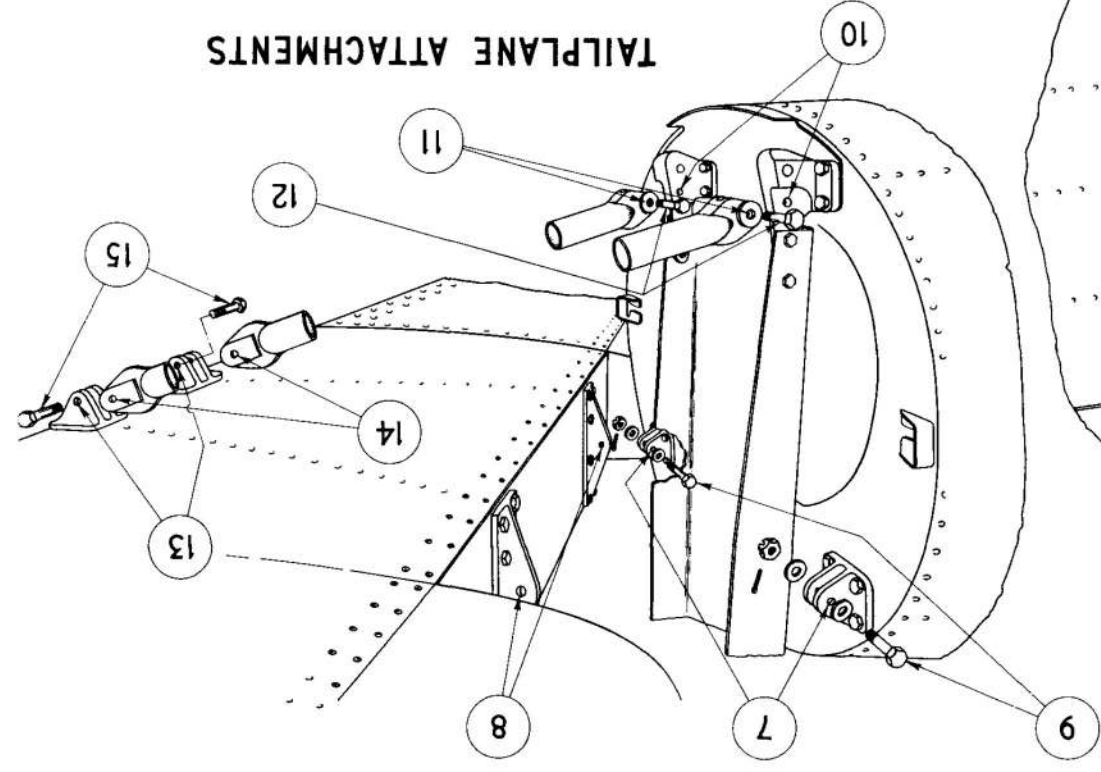

RESTRICTED

Engine mounting, fuselage and tailplane attachments

KEY TO FIG.9/1

Key No.	Description	Part No.	Max. wear dia. (in.)	Checking tool*	"As new" dia. (in.)	Rectification of worn components
1	Fuselage fitting	CL.FS.485-486	0.5655	R. CL.Y.101/G	9/16 + 0.0004	Renew
2	Top fitting	CL.EM.13	0.5655	R. CL.Y.101/G	9/16 + 0.0025	Renew
3	Special bolt	CL.E.159	0.5600	Micrometer	9/16 - 0.0006 + 0.0005	Renew
4	Fuselage fitting	CL.FS.139-140	0.5655	R. CL.Y.101/G	9/16 + 0.0004	Renew
5	Bottom fitting	CL.EM.15	0.5655	R. CL.Y.101/G	9/16 - 0.0005	Renew
6	Special bolt	CL.E.159	0.5600	Micrometer	9/16 - 0.0006 - 0.0012	Renew
7	Fuselage fitting	CL.FS.453	0.2510	R. CL.Y.101/A	1/4 + 0.0003	Apply for repair scheme
8	Tailplane fitting	CL.TP.167	0.2510	R. CL.Y.101/A	1/4 + 0.0003	Apply for repair scheme
9	Special bolt	CL.CF.715	0.2485	Micrometer	1/4 - 0.0002	Renew
10	Fuselage fitting	CL.FS.459-460	0.2510	R. CL.Y.101/A	1/4 + 0.0003	Apply for repair scheme
11	Strut	CL.T.5	0.2510	R. CL.Y.101/A	1/4 + 0.0003	Renew
12	Special bolt	CL.CF.713	0.2485	Micrometer	1/4 - 0.0002	Renew
13	Tailplane fitting	CL.FS.453	0.2510	R. CL.Y.101/A	1/4 + 0.0003	Apply for repair scheme
14	Strut	CL.T.5	0.2510	R. CL.Y.101/A	1/4 + 0.0003	Renew
15	Special bolt	CL.CF.715	0.2485	Micrometer	1/4 - 0.0002	Renew
16	Bush : Connecting rod	CL.CF.481	0.2550	R. CL.Y.101/H	1/4 + 0.0000	Renew
17	Special bolt	CL.CF.999	0.2470	Micrometer	1/4 - 0.0005 - 0.0050	Renew

* R. CL.Y.101 is a composite de Havilland plug gauge; the suffix letter specified in the above table refers to that part of the gauge which is to be used when checking the fitting concerned.

RESTRICTED

Fig. 9/2. Aligning gear

MAIN UNDERCARRIAGE

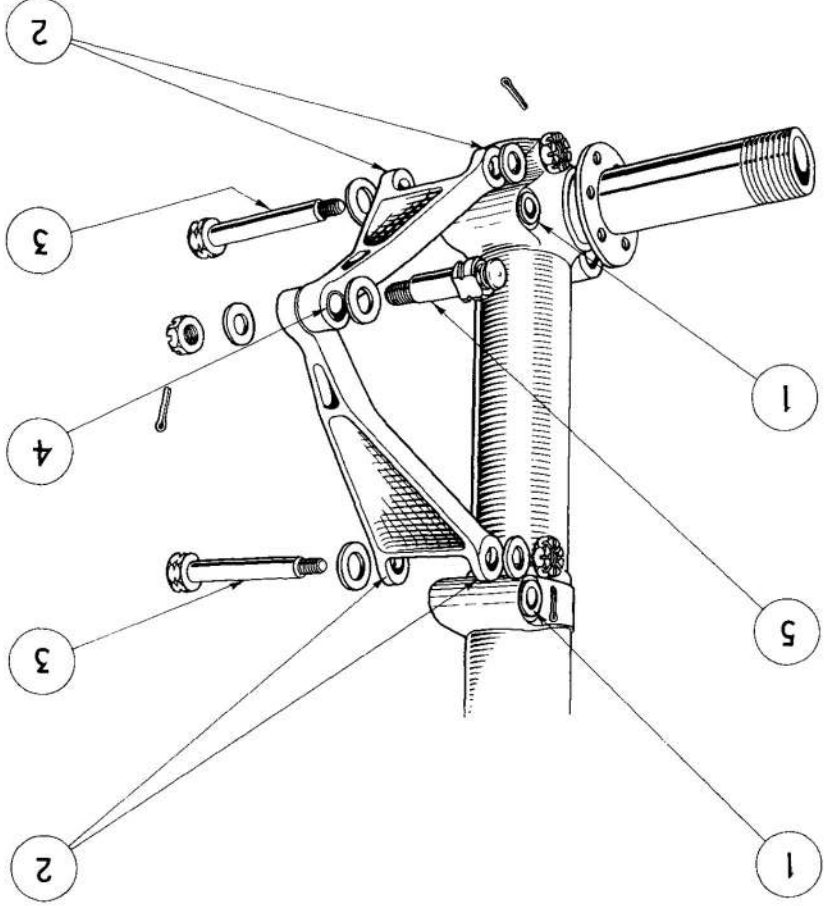

TAILWHEEL ASSEMBLY

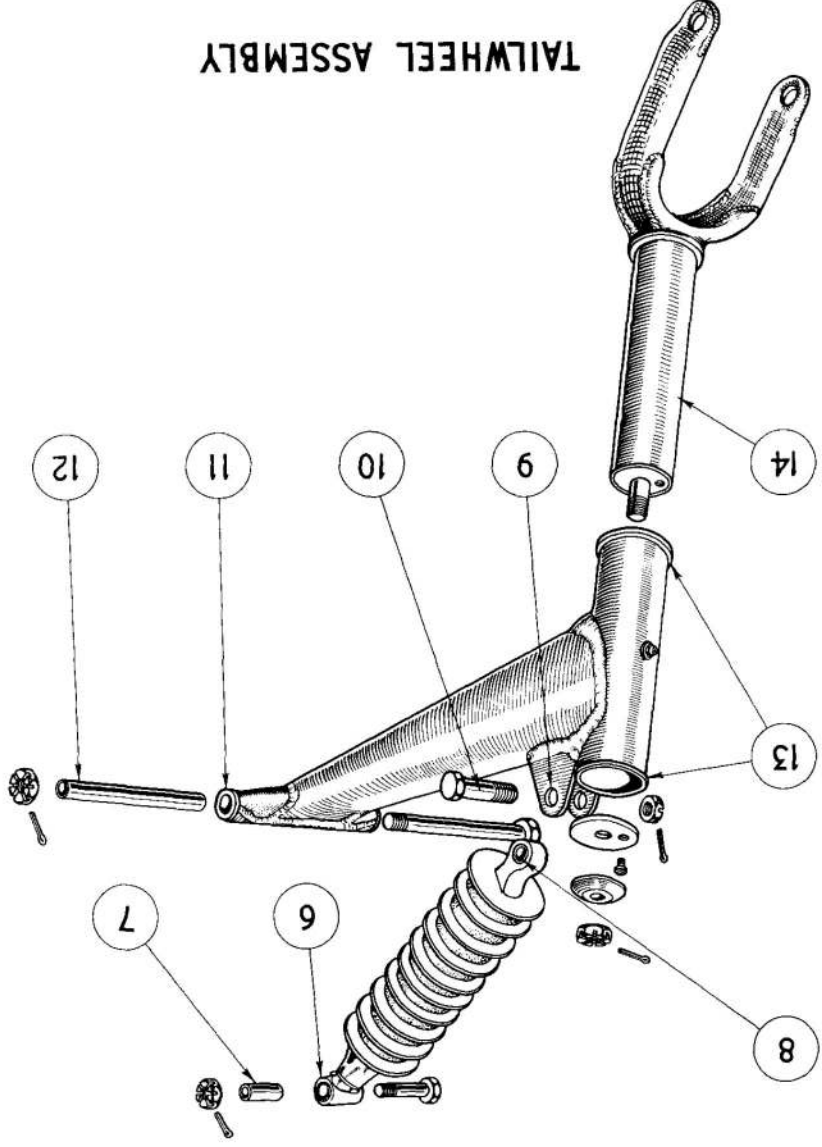

RESTRICTED

KEY TO FIG. 9/2

Aligning gear

Key No.	Description	Part No.	Max. wear dia. (in.)	Checking tool*	"As new" dia. (in.)	Rectification of worn components	Dia. of hole in fitting for oversize bush (in.)
1	Bush :	CI. U. 47	0.4390	R. CI. Y. 101/D	7/16 ± 0.0004	R. CI. U. 101 Renew or fit oversize bush,	0.5659
2	Torque link	CI. U. 7	0.4390	R. CI. Y. 101/D	7/16 ± 0.0004	Apply for repair scheme	-
3	Special bolt	CI. U. 9	0.4345	Micrometer	7/16 - 0.0006 Renew	Renew	-
4	Bush; Torque link	CI. U. 117	0.4390	R. CI. Y. 101/D	7/16 ± 0.0004	R. CI. U. 102 Renew or fit oversize bush,	0.5659
5	Hinge pin	CI. U. 119	0.4345	Micrometer	7/16 - 0.0012 Renew	Renew	-
6	Bush; Shock strut	CI. UT. 87	0.4390	R. CI. Y. 101/D	7/16 ± 0.0004	Renew	-
7	Distance tube	CI. UT. 33	0.4345	Micrometer	7/16 - 0.0012 Renew	Renew	-
8	Bush; Shock strut	CI. UT. 35	0.3765	R. CI. Y. 101/C	3/8 ± 0.0004	Renew	-
9	Yoke assembly	CI. UT. 91	0.3765	R. CI. Y. 101/C	3/8 ± 0.0004	Apply for repair scheme	-
10	Standard bolt	AL. 9J	0.3720	Micrometer	3/8 ± 0.0000 Renew	Renew	-
11	Bush; Yoke	CI. UT. 31	0.4390	R. CI. Y. 101/D	7/16 ± 0.0004	R. CI. UT. 102 Renew or fit oversize bush,	0.6285
12	Distance piece	CI. UT. 99	0.4345	Micrometer	7/16 - 0.0006 Renew	Renew	-
13	Bush : Yoke	CI. UT. 29	1.2530	R. CI. Y. 101/E	1.25 ± 0.0015	R. CI. UT. 101 Renew or fit oversize bush,	1.4036
14	Fork assembly	CI. UT. 11	1.2450	Micrometer	1.25 - 0.0020 Renew	Renew	-

* R. CI. Y. 101 is a composite de Havilland plug gauge; the suffix letter specified in the above table refers to that part of the gauge which is to be used when checking the fitting concerned.

RESTRICTED

Fig. 9/3. Main plane

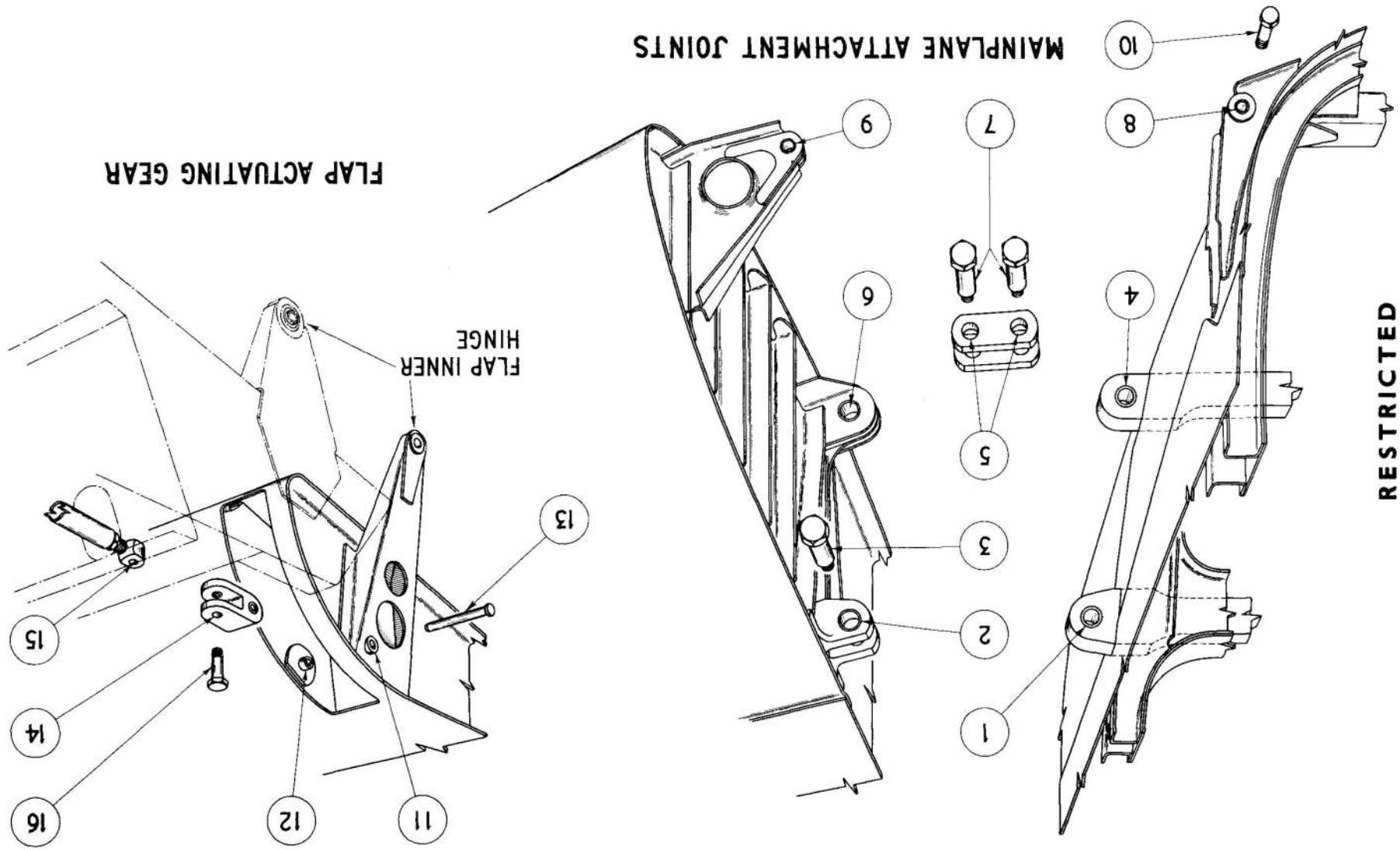

KEY TO FIG. 9/3

Main plane

Key No.	Description	Part No.	Max. wear dia. (in.)	Checking tool*	"As new" dia. (in.)	Rectification of worn components	Dia. of hole in fitting for oversize bush (in.)
1	Bush : Tie bar	CL. W. 77	0.7510	R. CL. Y. 101/F	3/4 + 0.0005	R. CL. W. 105 Renew or fit oversize bush,	0.8785
2	Bush : Wing fittings	CL. W. 75	0.7510	R. CL. Y. 101/F	3/4 + 0.0005	R. CL. W. 105 Renew or fit oversize bush,	0.8775
3	Special bolt	CL. W. 491	0.7485	Micrometer	3/4 - 0.0003 Renew	R. CL. W. 104	0.8775
4	Bush : Tie bar	CL. W. 77	0.7510	R. CL. Y. 101/F	3/4 + 0.0005	R. CL. W. 105 Renew or fit oversize bush,	0.8785
5	Links	CL. W. 493	0.7505	B. S. Plug gauge	3/4 + 0.0005	R. CL. W. 105 Renew	0.8775
6	Bush : Wing fitting	CL. W. 77	0.7510	R. CL. Y. 101/F	3/4 + 0.0005	R. CL. W. 105 Renew or fit oversize bush,	0.8785
7	Special bolts	CL. W. 495	0.7485	Micrometer	3/4 - 0.0003 Renew	R. CL. W. 105	0.8775
8	Bush : Fuselage frame	CL. F.S. 51	0.3765	R. CL. Y. 101/C	3/8 + 0.0004	R. CL. F. 116 Renew or fit oversize bush,	0.5034
9	Bush : Nose spar	CL. W. 87	0.3765	R. CL. Y. 101/C	3/8 + 0.0004	R. CL. W. 106 Renew or fit oversize bush,	0.5670
10	Standard bolt	A15. 10J	0.3720	Micrometer	3/8 - 0.0005 Renew	R. CL. W. 106	0.5665
11	Hinge bracket	CL. W.F. 81-2	0.3160	R. CL. Y. 101/B	5/16 + 0.0004 Renew	R. CL. W. 106	-
12	Bearing plate	CL. W.F. 75	0.3160	R. CL. Y. 101/B	5/16 + 0.0004 Renew	R. CL. W. 106	-
13	Pin	CL. W.F. 73	0.3080	Micrometer	5/16 - 0.0012 Renew	R. CL. W. 106	-
14	Fork fitting	CL. W.F. 67	0.3160	R. CL. Y. 101/B	5/16 + 0.0003 Renew	R. CL. W. 106	-
15	Eye end : Connecting rod	CL. CF. 263	0.3160	R. CL. Y. 101/B	5/16 + 0.0004 Renew	R. CL. W. 106	-
16	Special bolt	CL. CF. 1163	0.3080	Micrometer	5/16 - 0.0015 Renew	R. CL. W. 106	-

* R. CL. Y. 101 is a composite de Havilland plug gauge; the suffix letter specified in the above table refers to that part of the gauge which is to be used when checking the fitting concerned.

RESTRICTED

This file was downloaded
from the RTFM Library.

Link: www.scottbouch.com/rtfm

Please see site for usage terms,
and more aircraft documents.

