

FUSELAGE

Renewal of rear portion
(Completely revised)

In the event of heavy damage affecting the rear fuselage this portion can be removed and a replacement effected as instructed.

Preparation

1. (1) Remove the damaged rear end by releasing attachment of joint strap securing front and rear fuselage.
- (2) Set up the front fuselage on suitable trestles to maintain it in a level position. All trestles must be located beneath a former and use must be made of a pre-formed wooden support between the trestles and the fuselage to prevent concentration of the load at one point.

- (3) Project a datum below the fuselage as shown in the illustration. This enables a cross check on the fuselage level by measuring the dimensions at the various joints on the structure.
- (4) In the production of the fuselage components the rear end of the front portion has been designed as a close fit in the joint strap fitted at the front end of the rear fuselage. A jig must be assembled as shown in fig. 1.
- (5) In some few cases it may be found that datum pegs have not been fitted. In such cases fore and aft and lateral levelling may be effected by use of a clinometer carried on a straight edge sup-

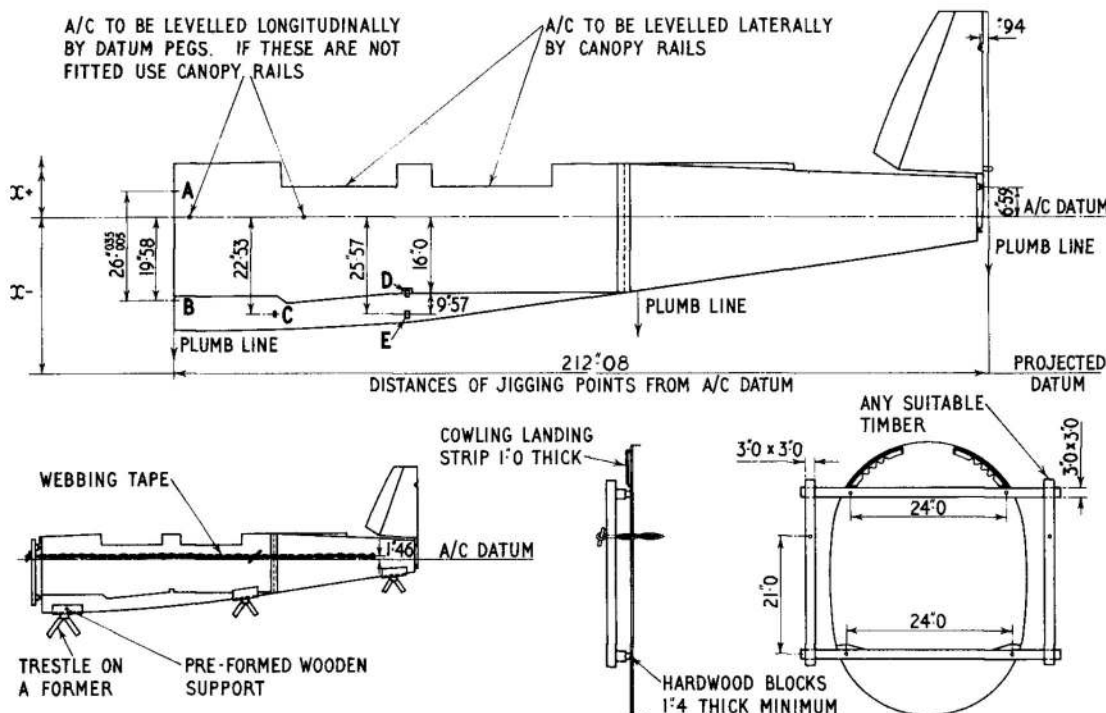

Fig. 1. General arrangement of repair

RESTRICTED

ported across the canopy rails. It will be necessary also to make an accurate check of the dimensions to the projected datum.

Repair method

2. (1) With the fin fitted, offer up a fuselage rear end, Part No. R C1 FS 157, to its approximate position and check that it is vertical by measuring the distance of the plumb line from the top hinge position as shown in fig. 1. Make a symmetry check of the diagonal measurements from the underside of the rear bulkhead (Vol. 1).
- (2) Fit the tail lifting bar and by means of webbing tapes on each side of the fuselage rig tourniquets and draw the two compon-

ents together as shown in the illustration.

(3) Check height of tailplane attachments from the projected datum and their distance from the firewall (fig. 1).

(4) Again check that the fin is vertical and that the three plumb lines are in alignment. If the rear fuselage stringer bracket lugs do not meet the rear face of former 8 and they should be packed with shims shown and secured with attachments shown in fig. 2.

(5) Drill for 5/32 in. dia. rivets in joint strap from the inside using the existing 1/8 in. dia. holes in the front portion as a template. Complete the fuselage by riveting up.

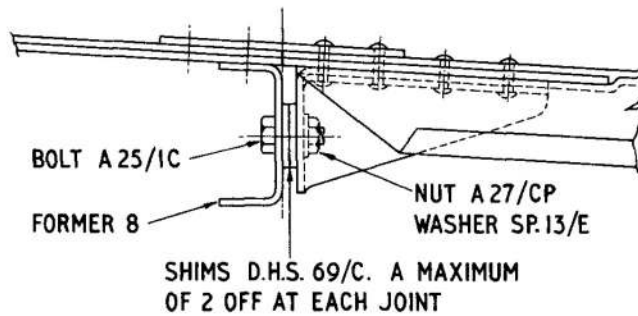

Fig. 2. Stringer bracket attachment

Estimation of bench hours

3. The repair outlined will take approximately 120 bench hours.

Repair material

4. The following repair material will be required :-

Stores Ref.	Description	Size or s. w. g.	Specification
28D/9436920	Bolt A. 25. 1C	2 B. A.	
28M/940320	Nut A. 27. CP	2 B. A.	
28W/9419402	Washer SP. 13C	2 B. A.	
28Q/10653	Rivet AS. 2228/505	5/32 in. dia.	L. 69
28Q/11659	Rivet AS. 2228/506	5/32 in. dia.	L. 69

Rear fuselage Pt. No. R. C1. FS. 157

RESTRICTED

This file was downloaded
from the RTFM Library.

Link: www.scottbouch.com/rtfm

Please see site for usage terms,
and more aircraft documents.

