

RESTRICTED

AIR PUBLICATION 4321A
VOL. 3, PART I
NOVEMBER 1950
1st EDITION

AVON I ENGINE

SCHEDULE OF SPARE PARTS

ENGINE SPARES R.A.F. VOCABULARY; SECTION No. 36VV

FUEL SYSTEM SPARES (LUCAS)
R.A.F. VOCABULARY SECTION No. 36LL

AIR MINISTRY

MEMORANDUM OF INSTRUCTIONS

1. **CONTENTS.** This schedule contains a complete list of Parts embodied in the **AVON MK. I** Engine.

2. **MULTI-INDENTATION SYSTEM.** The parts in the schedule are arranged in ~~alphabetical~~ ^{of assembly} order, and items are indented to show their correct relationship to each other. The following is a key diagram of the layout as used throughout the body of this schedule:—

1	2	3	4	5
MAIN ASSEMBLY details of main assembly				
SUB ASSEMBLY details of sub assembly				
SUB SUB ASSEMBLY details of sub sub assembly				
SUB SUB SUB ASSEMBLY details of sub sub sub assembly				
PARTS NOT INCLUDED IN MAIN ASSEMBLY				

3. **MR AND C/S COLUMN.** Items indicated M/ are required for Major Repair purposes only and will not normally be held in stock by Units other than those carrying out major repair work. A, B or C indicates class of store.

4. **NUMBER OFF COLUMN.** The number off shown against an Assembly or detail Part indicates the quantity required in the position shown and does not preclude the recurrence of the Assembly or detail Part in other positions in the complete major Assembly. In order to assess whether or not the Part recurs, reference should be made to the Reference/Part Number Index which quotes all pages where the Part/Assembly appears.

5. **DEMANDS.** Normally only those parts which have been allotted Reference Numbers in this Schedule are to be demanded from the appropriate Maintenance Unit under the Royal Air Force Vocabulary Section quoted. Demands and issue Vouchers are to be prepared in accordance with the procedure laid down in Air Publication 830, Vol. 1.

For further details of items shown in this Schedule under Sections other than 36 or 37, reference should be made to the relevant Section or A.P.1086.

RESTRICTED

Avon 1
A.L.20

vic

A.P.4321A, Vol.3

MODIFICATION RECORD SHEET

MOD. No.	A.L. No.	MOD. No.	A.L. No.	MOD. No.	A.L. No.	MOD. No.	A.L. No.	MOD. No.	A.L. No.	MOD. No.	A.L. No.	MOD. No.	A.L. No.
1080	N.A.	1126	N.A.	1172	N.A.	1218	N.A.	All Modifications from 1242 to					
1081	N.A.	1127	N.A.	1173	N.A.	1219	N.A.	4999 inclusive are reserved					
1082	N.A.	1128	N.A.	1174	19	1220	N.A.	for AVON 200 SERIES ENGINES					
1083		1129	N.A.	1175	N.A.	1221	N.A.						
1084	N.A.	1130	N.A.	1176	N.A.	1222	N.A.						
1085	N.A.	1131	N.A.	1177	N.A.	1223	N.A.						
1086	N.A.	1132	N.A.	1178	N.A.	1224	N.A.						
1087	19	1133	19	1179	19	1225	N.A.						
1088	N.A.	1134	19	1180	N.A.	1226	N.A.						
1089	19	1135	N.A.	1181	N.A.	1227	N.A.						
1090	N.A.	1136	N.A.	1182	N.A.	1228	N.A.						
1091	19	1137	N.A.	1183	N.A.	1229	N.A.						
1092	19	1138	N.A.	1184	N.A.	1230	19						
1093	N.A.	1139	N.A.	1185	N.A.	1231	N.A.						
1094	19	1140	N.A.	1186	N.A.	1232	N.A.						
1095	N.A.	1141	N.A.	1187	N.A.	1233	N.A.						
1096	19	1142	N.A.	1188	N.A.	1234	N.A.						
1097	N.A.	1143	N.A.	1189	N.A.	1235	N.A.						
1098	N.A.	1144	N.A.	1190	C	1236	N.A.						
1099	N.A.	1145	N.A.	1191		1237	N.A.						
1100	N.A.	1146	N.A.	1192	N.A.	1238	N.A.						
1101	N.A.	1147	N.A.	1193	N.A.	1239	N.A.						
1102	N.A.	1148	N.A.	1194	N.A.	1240							
1103	N.A.	1149	N.A.	1195	N.A.	1241	N.A.						
1104	N.A.	1150	N.A.	1196	N.A.								
1105	N.A.	1151	N.A.	1197	19								
1106	21	1152	N.A.	1198	19								
1107	N.A.	1153	N.A.	1199	N.A.								
1108	N.A.	1154	N.A.	1200	N.A.								
1109	N.A.	1155	N.A.	1201	N.A.								
1110	N.A.	1156	N.A.	1202	N.A.								
1111	N.A.	1157	N.A.	1203	N.A.								
1112	N.A.	1158	N.A.	1204	N.A.								
1113	N.A.	1159	N.A.	1205	N.A.								
1114	N.A.	1160	N.A.	1206	N.A.								
1115	N.A.	1161	N.A.	1207	N.A.								
1116	N.A.	1162	*	1208	N.A.								
1117	N.A.	1163	N.A.	1209	N.A.								
1118	*	1164	N.A.	1210	N.A.								
1119	N.A.	1165	N.A.	1211	N.A.								
1120	N.A.	1166	N.A.	1212	N.A.								
1121	N.A.	1167	N.A.	1213	*								
1122	N.A.	1168	N.A.	1214	N.A.								
1123	N.A.	1169	N.A.	1215	N.A.								
1124	N.A.	1170	N.A.	1216	19								
1125	N.A.	1171	N.A.	1217	N.A.								

- * Modifications Incorporated
- C Modifications cancelled
- N.A. Modifications not applicable to this schedule

RESTRICTED

Avon 1 and 102

vid

A, P, 4321A, Vol. 3

MODIFICATION RECORD SHEET

A. L. 39

MOD. No.	A.L. No.	MOD. No.	A.L. No.	MOD. No.	A.L. No.	MOD. No.	A.L. No.	MOD. No.	A.L. No.	MOD. No.	A.L. No.	MOD. No.	A.L. No.
5000	NA	5045	NA	5090	NA	5135		5180	NA	5225		5270	
5001	NA	5046	NA	5091	NA	5136	20	5181		5226		5271	
5002	NA	5047	NA	5092	NA	5137		5182		5227	NA	5272	
5003	20	5048	C	5093	NA	5138	22	5183		5228		5273	27
5004	NA	5049	NA	5094	NA	5139	21	5184	NA	5229		5274	NA
5005	NA	5050	NA	5095	NA	5140	22	5185		5230	NA	5275	
5006	NA	5051	NA	5096	NA	5142	NA	5186		5231		5276	25
5007	NA	5052	20	5097	NA	5142	22	5187	NA	5232		5277	25
5008	NA	5053	20	5098	NA	5143	NA	5188		5233	NA	5278	39
5009	NA	5054	20	5099	NA	5144	NA	5189		5234		5279	25
5010		5055	20	5100	NA	5145	21	5190	25	5235	25	5280	
5011	NA	5056	NA	5101	NA	5146	NA	5191	22	5236	NA	5281	NA
5012	19	5057	20	5102	20	5147	NA	5192	NA	5237		5282	26
5013	NA	5058	NA	5103	NA	5148	22	5193	NA	5238		5283	
5014	20	5059	20	5104	NA	5149	NA	5194	NA	5239		5284	23
5015	19	5060	NA	5105	NA	5150		5195		5240		5285	
5016	19	5061	20	5106	NA	5151	NA	5196		5241	NA	5286	
5017	NA	5062	NA	5107	NA	5152		5197		5242	NA	5287	23
5018	NA	5063	NA	5108		5153	NA	5198		5243	NA	5288	NA
5019	NA	5064	NA	5109	NA	5154	NA	5199		5244	25	5289	NA
5020	NA	5065	NA	5110		5155		5200		5245	NA	5290	NA
5021	NA	5066	NA	5111	21	5156	NA	5201		5246	23	5291	26
5022	NA	5067	NA	5112		5157	NA	5202	NA	5247	NA	5292	NA
5023	NA	5068	NA	5113	NA	5158	NA	5203	NA	5248		5293	26
5024	NA	5069	NA	5114	21	5159		5204		5249	25	5294	
5025	NA	5070	NA	5115	NA	5160	NA	5205	22	5250	26	5295	27
5026	21	5071	NA	5116	20	5161		5206	NA	5251		5296	
5027	21	5072	NA	5117	NA	5162		5207		5252	27	5297	
5028	C	5073	NA	5118		5163		5208	NA	5253	25	5298	NA
5029	NA	5074	NA	5119		5164		5209	NA	5254		5299	
5030	NA	5075	20	5120		5165	NA	5210		5255	NA	5300	23
5031	NA	5076	NA	5121	25	5166		5211		5256		5301	NA
5032	20	5077	NA	5122	NA	5167	NA	5212	NA	5257		5302	NA
5033	NA	5078	NA	5123	NA	5168	NA	5213	NA	5258	NA	5303	NA
5034	20	5079	NA	5124		5169	NA	5214	NA	5259	NA	5304	
5035	29	5080	NA	5125		5170		5215		5260		5305	NA
5036	NA	5081	NA	5126	NA	5171		5216	NA	5261		5306	NA
5037	21	5082	NA	5127	NA	5172		5217		5262		5307	
5038	NA	5083	NA	5128		5173	NA	5218		5263	NA	5308	26
5039	20	5084	NA	5129		5174	27	5219		5264	NA	5309	
5040	21	5085	NA	5130	21	5175	NA	5220		5265	NA	5310	NA
5041	NA	5086	NA	5131	NA	5176	22	5221	NA	5266	NA	5311	NA
5042	NA	5087	20	5132		5177	NA	5222	25	5267		5312	NA
5043	NA	5088	NA	5133	20	5178	NA	5223		5268	25	5313	27
5044	NA	5089	NA	5134	NA	5179		5224	NA	5269		5314	

* Modifications incorporated

C Modifications cancelled

N.A. Modifications not applicable to this schedule

RESTRICTED

Avon 1 and 102

v i e

AP4321A, Vol.3

MODIFICATION RECORD SHEET

A.L.40

MOD No.	A.L. No.	MOD No.	A.L. No.	MOD. No.	A.L. No.	MOD. No.	A.L. No.	MOD. No.	A.L. No.	MOD. No.	A.L. No.	MOD. No.	A.L. No.
5315	NA	5361		5407	29	5453	36	5499					
5316	NA	5362		5408		5454	NA	5500					
5317	27	5363		5409		5455	NA	5501					
5318	NA	5364	NA	5410	NA	5456	NA	5502					
5319	NA	5365		5411	NA	5457	NA	5503					
5320	26	5366	NA	5412	NA	5458	37	5504					
5321	NA	5367	NA	5413	NA	5459	NA	5505					
5322	NA	5368		5414		5460	NA	5506					
5323	27	5369		5415	29	5461	NA	5507					
5324		5370	NA	5416	NA	5462	36	5508					
5325	NA	5371	NA	5417	NA	5463	NA	5509					
5326	NA	5372		5418		5464	37	5510					
5327	NA	5373	27	5419	31	5465		5511					
5328	NA	5374	NA	5420	NA	5466	NA	5512					
5329		5375	28	5421	NA	5467		5513					
5330		5376	33	5422	NA	5468	NA	5514					
5331	NA	5377	NA	5423	NA	5469		5515					
5332	NA	5378	NA	5424	NA	5470	38	5516					
5333	NA	5379	27	5425	NA	5471	NA	5517					
5334	NA	5380	27	5426		5472	NA	5518					
5335	NA	5381	NA	5427	33	5473	NA	5519					
5336	NA	5382		5428	NA	5474	39	5520					
5337		5383		5429	NA	5475		5521					
5338	NA	5384		5430	NA	5476		5522					
5339		5385		5431		5477		5523					
5340		5386	NA	5432	34	5478	38	5524					
5341		5387		5433	NA	5479	38	5525					
5342	NA	5388	NA	5434	NA	5480	38	5526					
5343	27	5389	NA	5435	33	5481	NA	5527					
5344		5390	27	5436		5482	40	5528					
5345	NA	5391	NA	5437	NA	5483	NA	5529					
5346	NA	5392	NA	5438	NA	5484	NA	5530					
5347	NA	5393		5439	NA	5485	40	5531					
5348	27	5394	NA	5440	34	5486	NA	5532					
5349	27	5395	NA	5441	NA	5487	NA	5533					
5350	27	5396	NA	5442	NA	5488	NA	5534					
5351	NA	5397		5443	33	5489	40	5535					
5352		5398	NA	5444		5490		5536					
5353		5399		5445	NA	5491		5537					
5354	27	5400		5446		5492	NA	5538					
5355	27	5401		5447	35	5493		5539					
5356	28	5402	34	5448	C	5494		5540					
5357	32	5403	NA	5449	NA	5495		5541					
5358	27	5404		5450	NA	5496		5542					
5359	NA	5405	NA	5451	NA	5497		5543					
5360	NA	5406		5452	36	5498		5544					

- * Modifications incorporated
- C Modifications cancelled
- N.A. Modifications not applicable to this schedule

MODIFICATION RECORD SHEET LUCAS FUEL SYSTEM COMPONENTS

Mod. No.	A.L. No.	Mod. No.	A.L. No.	Mod. No.	A.L. No.	Mod. No.	A.L. No.	Mod. No.	A.L. No.	Mod. No.	A.L. No.	Mod. No.	A.L. No.
CP190		CP211		CP232		CP253		CP274		CP295		CP316	
CP191		CP212		CP233		CP254		CP275		CP296		CP317	
CP192		CP213		CP234		CP255		CP276		CP297		CP318	
CP193		CP214		CP235		CP256		CP277		CP298		CP319	
CP194	1	CP215		CP236		CP257		CP278		CP299		CP320	
CP195		CP216		CP237		CP258		CP279		CP300		CP321	
CP196		CP217		CP238		CP259		CP280		CP301		CP322	
CP197		CP218		CP239		CP260		CP281		CP302		CP323	
CP198		CP219		CP240		CP261		CP282		CP303		CP324	
CP199		CP220		CP241		CP262		CP283		CP304		CP325	
CP200		CP221		CP242		CP263	5	CP284		CP305		CP326	
CP201		CP222		CP243		CP264		CP285		CP306		CP327	
CP202		CP223		CP244		CP265		CP286		CP307		CP328	
CP203	3	CP224		CP245		CP266		CP287		CP308		CP329	
CP204		CP225		CP246		CP267		CP288		CP309		CP330	
CP205		CP226	5	CP247		CP268		CP289		CP310		CP331	
CP206		CP227		CP248		CP269		CP290		CP311		CP332	
CP207		CP228		CP249		CP270		CP291		CP312		CP333	
CP208		CP229		CP250		CP271		CP292		CP313		CP334	
CP209		CP230		CP251		CP272		CP293		CP314		CP335	
CP210	3	CP231		CP252		CP273		CP294		CP315		CP336	

* Modifications incorporated in initial issue of schedule.

© Modifications cancelled.

N.A. Modifications not applicable to this schedule.

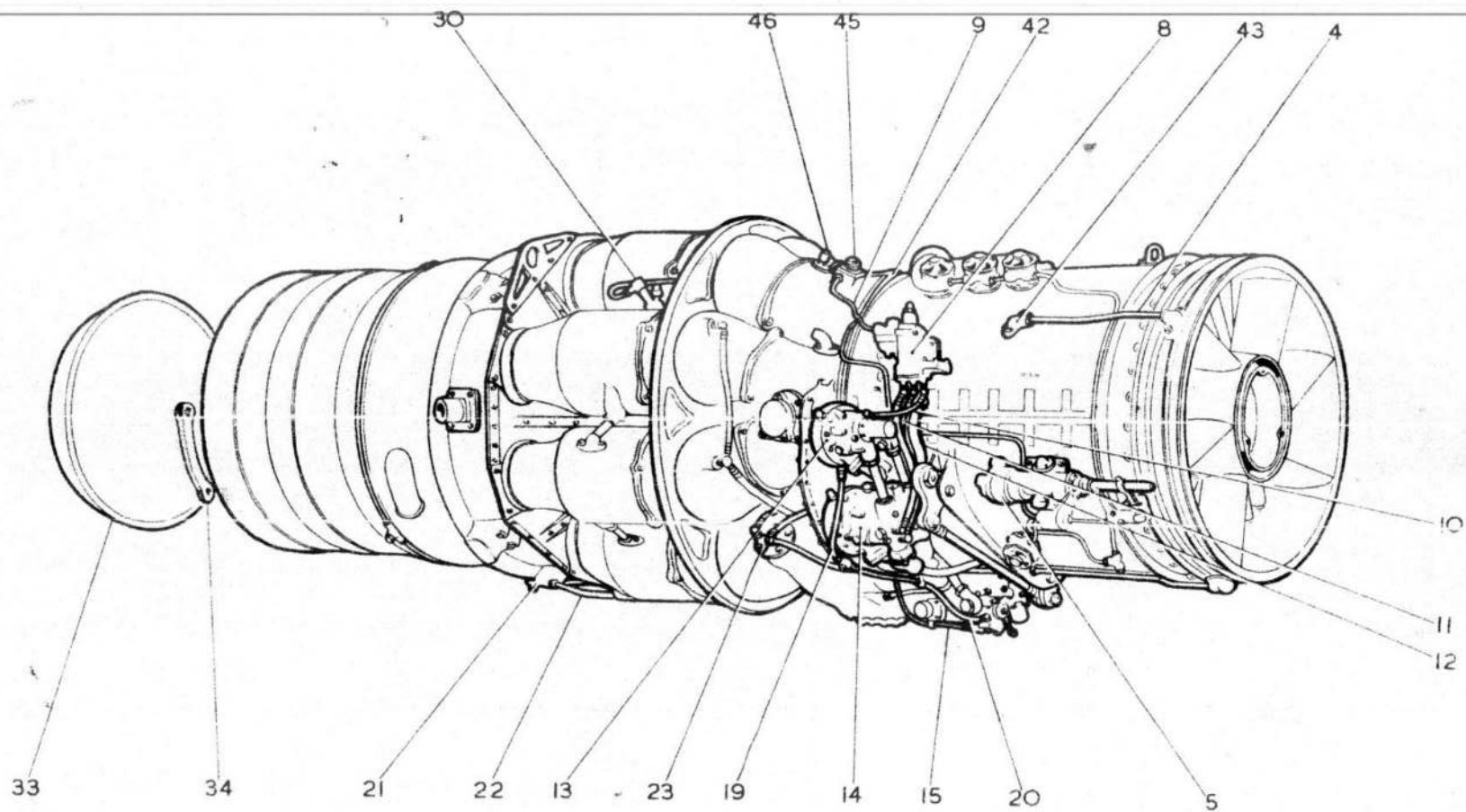

CHECKING LIST ITEMS (RESTRICTED) AL15

AVON I

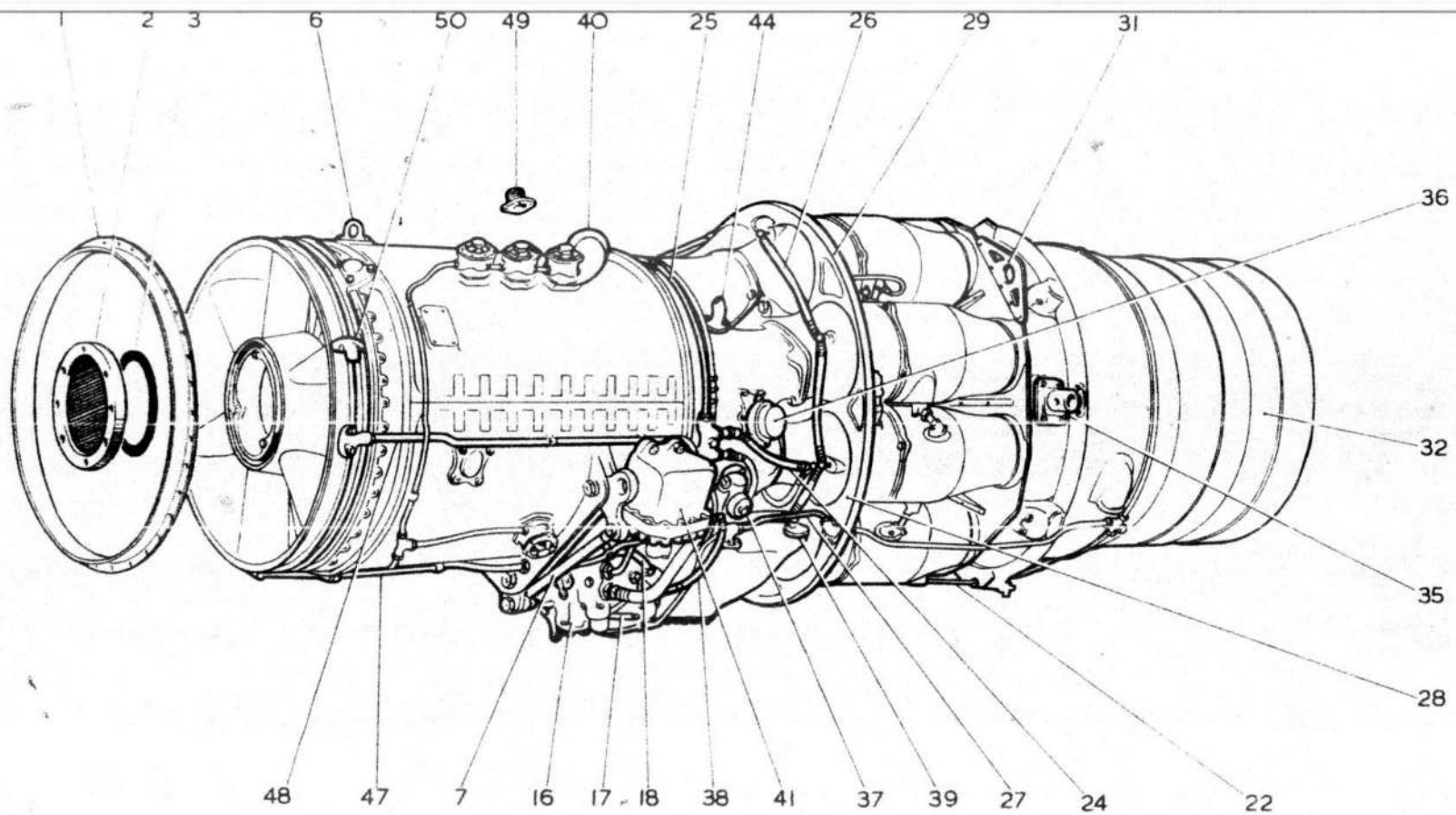

XI

CHECKING LIST ITEMS (RESTRICTED) AL15

AVON I

AIR MINISTRY CHECKING LIST
FOR AVON 1 AERO ENGINES
AS INSTALLED IN CANBERRA AIRCRAFT

This checking list has been prepared to show only those items of a readily detachable nature or about which doubt may exist whether they should form part of, or should be transferred with, the engine. The list consequently excludes those other engine components which are not liable to incidental removal, but personnel are not thereby relieved of the responsibility for checking and recording, in accordance with the regulations, discrepancies of such components.

The engine is to be vouched as instructed in A.P.830, Vol.1, 5th Edition, Part 2, Leaflet B 9/1, quoting the Air Publication and latest issue number of the checking list.

1. The fitting of an alternative item of different type or part number but falling within the same generic heading of a checking list item does not constitute a discrepancy.
2. During storage or transit of the engine, all exposed apertures, pipe ends, unions etc. are to be suitably blanked off to prevent the ingress of foreign matter.
3. Every effort should be made to despatch the log book with the engine, and the log book should record the shortage of major components.
4. It must be clearly understood that all items included in the checking lists are to be accounted for notwithstanding the fact that certain items may not be required for the specific airframe into which the engine is installed and the relevant issue or receipt vouchers and Forms 530 are to be suitably endorsed to show the shortages. Similar action is to be taken regarding surplus items (Forms 729 are also to be suitably endorsed by the resident Inspector-in-Charge, A.I.D., at the contractor's works).
5. The engine is to be transferred complete to checking lists unless instructions are issued to the contrary, or through exceptional circumstances, e.g. parts lost in crash, modifications etc.
6. The items listed below are not to be regarded as part of, or transferred with, this engine :-
 - (i) Motor, starter, electric or Turbo starter complete with fairing
 - (ii) Pipe, jet
 - (iii) Shaft, driving, for auxiliary gearbox
 - (iv) Generator, for engine speed indicator
 - (v) Tool kit

Continued

AIR MINISTRY CHECKING LIST Continued

Item No.	Description	Qty. per Engine
1	Ring, sealing, air intake	1
2	Cover, blanking, for turbo starter on inlet casing	1
3	Ring, starter fairing	1
4	Pipe, rigid, air feed to front bearing	1
5	Ram operating inlet guide vanes	1
6	Eye, lifting, engine on compressor casing	1
7	Suspension, front engine locating, complete with two sphericals	1
8	Unit, acceleration control	1
9	Pipe, rigid, from compressor casing outlet casing adaptor to acceleration control unit	1
10	Pipe, flexible, accelerator control unit to upper fuel pump solenoid	1
11	Pipe, flexible, accelerator unit to bottom fuel pump metering valve	2
12	Pipe, flexible, accelerator unit to bottom fuel pump inlet	1
13	Pump, fuel, upper, complete with solenoid	1
14	Pump, fuel, lower, complete with metering unit	1
15	Pipe, rigid, from barometric pressure control return to pump inlet	1
16	Unit, fuel control, comprises: Pressurising valve, shut-off cock and throttle valve; Barometric pressure control and low pressure filter	1
17	Pipe, flexible, H.P. pump pressure to barometric pressure control	1
18	Pipe, flexible and rigid, from servo-interconnecting upper to lower fuel pump and barometric pressure control	1 set
19	Pipe, flexible, spill, from upper fuel pump to lower fuel pump	1
20	Pipe, flexible, spill, from lower fuel pump to drain connection	1
21	Connection, drain valve assembly	1
22	Pipe, rigid, from No's.4 and 5 combustion chambers to drain valve	2
23	Pipe, flexible, pilot manifold, from connection on sump to burners	1
24	Pipe, flexible, from pilot manifold to burners	1 set
25	Pipe, pilot manifold	1 set
26	Pipe, flexible, manifold main burners	1 set
27	Pipe, fire extinguisher on compressor casing and exhaust cone with interconnecting pipe	1 set
28	Fireproof bulkhead (3 pieces)	1
29	Ring, joint, for fireproof bulkhead (rubber)	1
30	Plugs, high energy igniter	2
31	Plates, rear slinging engine attachment	2
32	Cone, exhaust, complete	1
33	Cover, blanking, for exhaust cone	1

Continued

AIR MINISTRY CHECKING LIST Continued

Item No.	Description	Qty. per Engine
34	Rings, clamping, for transitional unit	2
35	Trunnion, rear engine mounting	2
36	Cover, blanking, for gearbox drive	2
37	Transmitter, oil pressure unit	1
38	Pipe, flexible, spill, from oil cooler to draining connection	1
39	Cap, filter oil sump	1
40	Valve, bleed, on compressor casing	8
41	Cooler, oil, fuel cooled	1
42	Pipe, rigid, from bleed control unit to compressor casing, 7 stage tapping	1
43	Adaptor, for compressor delivery pressure tapping	1
44	Breather, on outlet casing	4
45	Connection, H.P. cabin pressure on compressor outlet casing	1
46	Connection, on outlet casing fuel tank pressurisation	1
47	Pipe, rigid, oil feed front bearing from inlet casing to sump	2
48	Pipe, rigid, ram pressure from intake casing to barometric pressure control	1
49	Connection, L.P. cabin pressure on compressor casing	1
50	Connection, electrical, on intake casing, for turbo starter	1

ISSUE NUMBER OF CHECKING LIST

ISSUE No.	5				
AMENDT. No.	15				
DATE	Oct.1955				

NOTE: The amendment list number quoted above is the latest affecting the checking list and may not necessarily be in numerical order, or the latest amendment to the Volume 3.

RESTRICTED

Avon 1 and 102

A.L. 34

xiv

A.P.4321A, Vol.3, Part 1

INDEX OF MAIN ASSEMBLIES Continued

Sec No.	Description	G.A. Drg. No.	Page No.	Plate No.
	FRONT BEARING HOUSING AND FITTINGS	BA.46930	173	26
	FRONT SUSPENSION	BA.20290	191	27
	FUEL CONTROL UNIT, COMBINED (MOD.697)	BA.70573	195	28, 28A, 28B
	FUEL PIPES AND FITTINGS (PRE-MOD.174)	BA.22057	207	29, 30, 31
	(MOD.175)	BA.46931	227	31A, 31B
	GOVERNOR PUMP (MOD.641)	BA.68559	228Q	31C
	INTERNAL WHEELCASE AND GEARS	BA.22053	229	32, 33
	JET PIPE	BA.22072	244	34
	NOZZLE BOX AND GUIDE VANES	BA.22142	267	35, 36
	OIL COOLER (FUEL COOLED)	BA.22071	284	37
	OIL PIPES AND FITTINGS	BA.22689	292	38
	OIL PUMPS	BA.22064	300	39
	OIL SUMP AND FILTER CASING	BA.22063	304	40, 41
	RAM, OPERATING, INLET GUIDE VANES (MOD.960)	BA.81235	327	42, 43, 43A
		BA.43760		
	REAR BEARING HOUSING AND INTERMEDIATE CASING	BA.22056	339	44, 45
	STARTER, TURBO, SINGLE BREECH	-	347	
	TORCH IGNITER AND FITTINGS (PRE-MOD.174)	BA.22061	349	46
	TURBINE WHEELS AND SHAFTS	BA.19686	353	47
	WIRING CONNECTIONS, TURBO STARTER		359	
	(SINGLE BREECH) (PRE-MOD.40)	BA.22060*		
	(MOD.40) (PRE-MOD.5402)	BA.32312*		
	(MOD.5402)	GP.6832		

Continued

RESTRICTED

Avon 1 and 102

xv

INDEX OF MAIN ASSEMBLIES Continued

A.P.4321A, Vol.3

A.L.39

Sec No.	Description	G.A. Drg. No.	Page No.	Plate No.
	TRANSPORTATION PARTS (AVON 1)	BA.23007	361	48,48A
	TRANSPORTATION PARTS (AVON 102)(MOD.5432)	GP.10894		
	SPECIAL REPAIR PARTS	-	367	
	LUCAS FUEL SYSTEM COMPONENTS:- BAROMETRIC PRESSURE CONTROL	BPC.15/18K	385	51
	CONSTANT PRESSURE FUEL PUMP, UPPER	GB.239/5C	405	52,53
	CONSTANT PRESSURE FUEL PUMP, LOWER (MOD.30 PRE-MOD.130)	GB.238/1C	419	54,55
	CONSTANT PRESSURE FUEL PUMP, LOWER (MOD.130)	GB.238/4C	424E	
	GENERATOR TACHOMETER (MOD.5142)	2708672	424F	
	LOW FUEL PRESSURE WARNING LIGHT SWITCH (MOD.5142)	2701823	424G	
	INDEX OF REFERENCE NUMBERS	-	430	
	INDEX OF PART NUMBERS	-	478	
	INDEX OF NATO SOCK NUMBERS		531	

This file was downloaded
from the RTFM Library.

Link: www.scottbouch.com/rtfm

Please see site for usage terms,
and more aircraft documents.

