

RESTRICTED

AIR PUBLICATION 4326 C
VOLUME 3 PART I
JANUARY 1952
1st EDITION

**CANBERRA
PR. MK3
SCHEDULE OF SPARE PARTS**

AIR MINISTRY

THE AMENDMENTS PROMULGATED IN THE UNDERMENTIONED
AMENDMENT LISTS HAVE BEEN MADE IN THIS SCHEDULE.

Amendment List		Amendments made by	Date
Number	Date		
1	May 1953	W. Smith	21.10.53
2	December 53 January 54	W. Smith	20.1.54
3	January 1954	W. Smith	26.4.54
4		Incorporated	
5			
6			
7	April	Ben. Hayward	10.4.56
8			
9	Feb. 56	D. Morris	26.11.56
10	Jan. 1957	D. Morris	27.6.57
11	May 1957	D. Morris	10.4.57
12	July 1957	D. Morris	17.3.58
13	July 1958	D. Morris	27.1.59
14	Dec. 1958	D. Morris	14.5.59
15	April 1959	D. Morris	31.3.60
16	June 60	D. Morris	24.1.61
17	Jan. 61	D. Morris	7.6.61
18	Dec. 61	D. Morris	23.2.62
19	Dec. 62	D. Morris	26.3.63
20	Sept. 63	D. Morris	31.12.63
21	Feb. 64	D. Morris	15.6.64
22	Oct. 64	D. Morris	3.2.65
23	Oct. 66	D. Morris	13.4.67
24	May 67	D. Morris	10.10.68

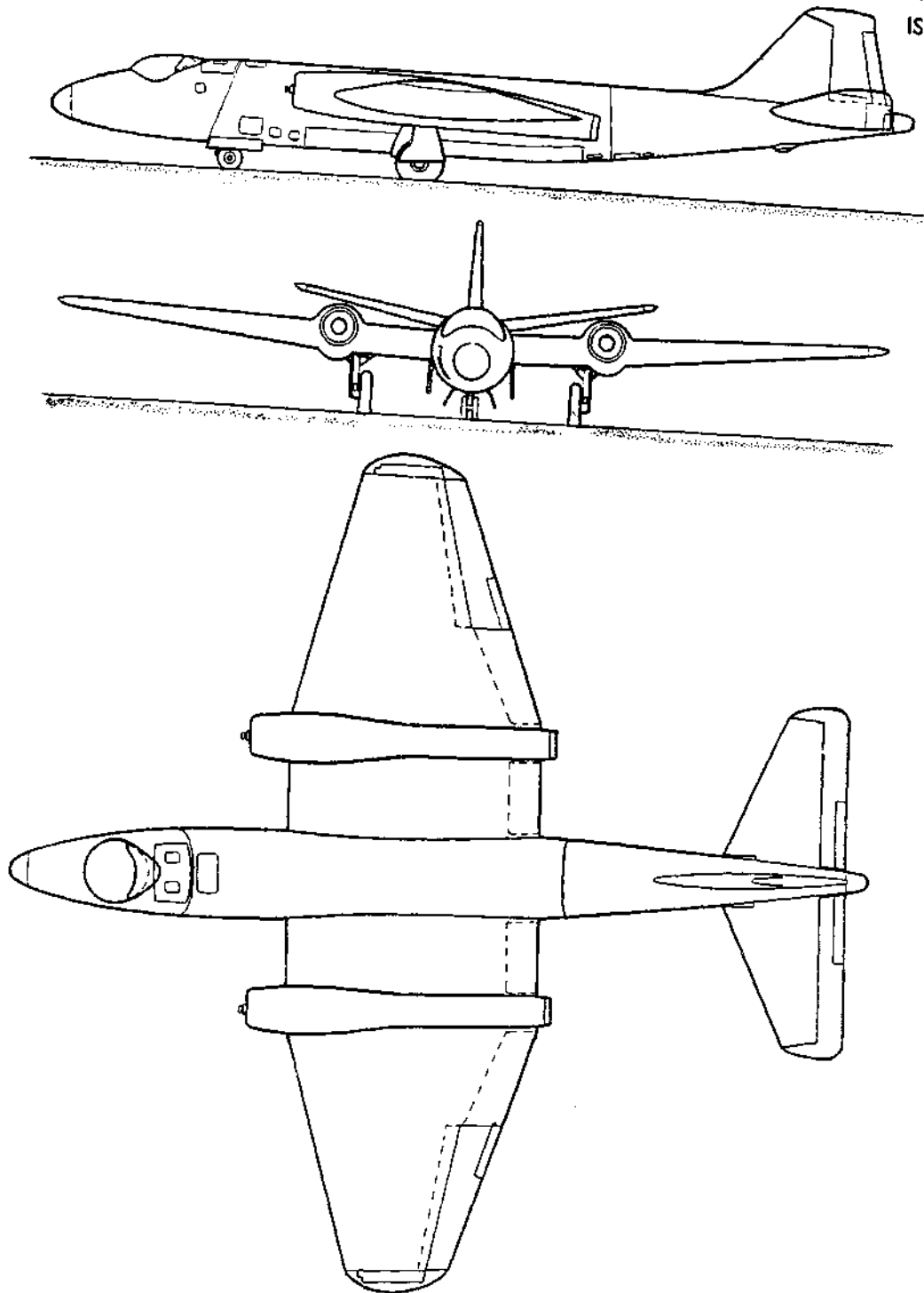

GENERAL ARRANGEMENT
(Data if for packing and storage only)

Duty : Photographic reconnaissances.

Type : Twin-engine monoplane.

DIMENSIONS

Wing span : 64ft. 0in.
Overall height : 15ft. 7in.
Overall length : 66ft. 8in.
Chord at root, 19ft. ; at tip 7ft. 8in.
Main plane dihedral : Inner wing,
2 deg. ; Outer wing, 4 deg. 21 min.
Incidence main plane, 2 deg.
Incidence tail plane variable, from
minus 3 deg. 22 mins. to plus 2 deg.
22 mins.
Tail plane dihedral, 10 deg.

AREAS

Main planes with ailerons, 960 sq. ft.
Ailerons (2), total 72 sq. ft.
Tail plane with elevators, 191 sq. ft.
Elevators, including horn, 58 sq. ft.
Fin, 31 sq. ft.
Rudder, 31 sq. ft.

FUEL TANK CAPACITIES

No. 1—237 galls.
No. 2—237 galls.
No. 3—214 galls.
No. 4—201 galls.
No. 5—540 galls.
Ventral (including collector box—
40 galls.), 440 galls.
Wing-tip jettisonable tanks (2) each
260 galls.
Total fuel, 2,389 galls.



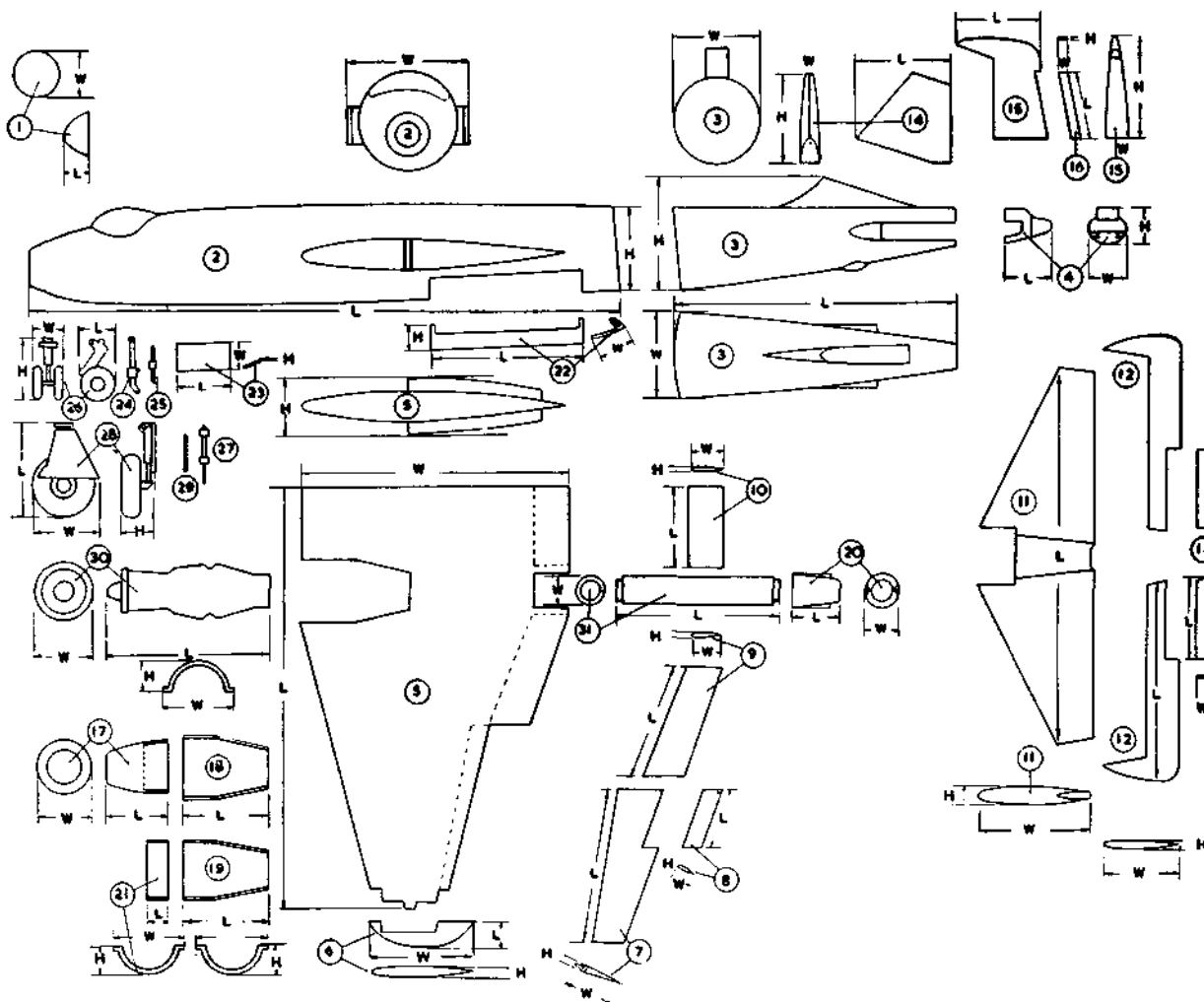

FIG. 6. COMPONENT WEIGHTS AND DIMENSIONS.

No.	COMPONENT	Length	Width	Height	Tare Wt. (lbs.)	Eqpd. Wt. (lbs.)	No.	COMPONENT	Length	Width	Height	Tare Wt. (lbs.)	Eqpd. Wt. (lbs.)
1	NOSE FAIRING ...	1' 5"	2' 7" diameter	—	56	—	19	ENGINE BOTTOM REAR COWL ...	5' 5"	2' 0"	1' 3"	33	—
2	FRONT FUSELAGE ...	42' 1"	7' 7"	6' 6"	2735	5470 less fuel	20	JET PIPE COWL ...	3' 8"	2' 8"	2' 7"	21	—
3	REAR FUSELAGE ...	19' 1"	5' 10"	7' 11"	510	600	21	SERVICE PANEL ...	2' 2"	2' 0"	1' 9"	15	—
4	REAR CONE ...	4' 9"	2' 5"	5' 10"	25	65	22	FLARE BAY DOORS ...	11' 5"	3' 0"	1' 8"	112	—
5	MAIN PLANE ...	28' 6"	19' 0"	4' 3"	2200	2620	23	NOSE U/C DOORS ...	4' 2"	1' 5"	3"	9	—
6	WING TIPS ...	1' 8"	7' 8"	10"	16	—	24	NOSE U/C RADIUS ROD ...	3' 11"	4"	8"	20	—
7	AILERON ...	12' 6"	1' 3"	9"	3	—	25	NOSE U/C JACK AND LEG ...	2' 2"	5"	6"	9	10
8	AILERON TAB ...	4' 2"	1' 8"	2"	3	—	26	NOSE U/C WHEEL AND LEG ...	2' 2"	1' 7"	3' 7"	230	—
9	FLAP, OUTBOARD ...	5' 11"	2' 9"	3"	34	—	27	MAIN U/C JACK AND LEG ...	1' 11"	4"	7"	14	16
10	FLAP, INBOARD ...	8' 7"	2' 6"	3"	22	—	28	MAIN U/C WHEEL AND LEG ...	6' 3"	3' 11"	2' 1"	600	—
11	TAIL PLANE ...	26' 0"	7' 9"	1' 5"	495	110	29	MAIN U/C SIDE STAY ...	2' 9"	8"	6"	36	—
12	ELEVATOR ...	13' 11"	4' 5"	8"	75	—	30	ENGINES ...	11' 0"	3' 6"	—	2280	—
13	ELEVATOR TAB ...	5' 7"	1' 6"	2"	8	—	31	JET PIPE ...	12' 3"	diameter 2' 2" diameter	—	180	—
14	FIN ...	6' 4"	1' 3"	6' 9"	94	—							
15	RUDDER ...	7' 1"	1' 3"	7' 0"	132	—							
16	RUDDER TAB ...	5' 5"	9"	2"	7	—							
17	ENGINE FRONT COWLING ...	13' 2"	3' 10"	3' 10"	59	—							
18	ENGINE TOP REAR COWL ...	5' 5"	2' 0"	1' 3"	30	—							





MEMORANDUM OF INSTRUCTIONS

1. CONTENTS

This Schedule contains a list of the Airframe Spare Parts embodied in Canberra P.R. MK.3 which have been allocated Vocabulary Section 26FZ.

2. DEMANDS

Units are to prepare their demands for spare parts strictly in accordance with A.P. 830, Vol. 1. Demands for the parts required to make an airframe serviceable are invariably to quote the Serial Number of the Aircraft. Units are to demand parts for this airframe under Vocabulary Section 26FZ except where the schedule states otherwise. Where the schedule states that a part is held under another Vocabulary Section the demand should quote that section after reference to the appropriate publication.

3. Unreferenced airframe items are not normally provisioned as spares. Demands for these items are to be submitted only when required to replace parts which have become unserviceable in use, or to meet anticipated requirements where previous consumption has been recorded. Such demands are to quote Maker's Part No.

4. Parts qualified by the symbol "LM" are to be manufactured by consumer units. If it is found that manufacture is beyond the capacity of the unit and that the requirement cannot be economically met by fitting an assembly bearing a reference number then the Unit should demand the part required under its part number and endorse demand "Unable to manufacture Locally".

5. When a Unit requires an unreferenced item which is beyond the Unit's capacity to manufacture or when a referenced part cannot be obtained consideration should be given to fitting the assembly of which this item is a part, if that assembly bears a reference number.

6. Certain items are annotated "MR". These are normally provisioned for issue only to Units and Contractors authorised to undertake the major repair of Canberra P.R. MK.3 airframes.

7. MODIFICATIONS (CLASSES 1 or 2)

When an item is introduced by a modification the modification number is shown after the description of the item. Redundant items are deleted from the text.

8. MODIFICATIONS (CLASSES 3 and 4) AND AMENDMENTS

When an item is introduced by this authority the No. is shown after the description. Parts rendered redundant are not to be deleted from the publication, but the description of these items must include the additional words "(PRE MOD.)". New items added must include, in the description, the words "(MOD.)".

9. OBSOLESCENT STOCK

An asterisk (*) shown in the Part No. column of an item indicates that no further purchase of the item will be made but that stocks will be issued until they are exhausted.

10. NUMBERS OFF

The figure in the Number Off column indicates:—

- (a) The quantity required per airframe when the description is NOT indented.
(b) The quantity required per assembly or sub-assembly when the description IS indented.

11. COMPILATION OF TEXT

The multi-indentation system has been used in which the main assemblies, sub-assemblies, groups and detail items indicate their relationship by the indentation of the descriptive titles. This indentation is in accordance with the following outline:—

- (a) Main assembly, sub-assemblies, separate groups and detail parts of the main assembly start at the left-hand margin. The main assembly is distinguished by bold capital type from the remainder.
- (b) First division: sub-sub-assemblies, groups or detail parts of the major breakdown listed in the preceding paragraph are indented one space.
- (c) Second division: groups or items are indented one further space.
- (d) Third and subsequent divisions: in sequence.

12. MAIN ASSEMBLY DRAWINGS

Where for description or identification purposes only a Main Assembly drawing is shown, that drawing number is shown in brackets at the end of the description.

13. PIPE LINES AND FLEXIBLE CABLES

Local manufacture of these items is intended wherever possible. Charts showing the various materials and parts required are included as appendices at the end of the schedule.

14. AMENDMENT LISTS

Amendments are to be correctly inserted and entered in the Amendment Certificate which is to be found in front of the schedule. Manuscript amendments are to be made in ink.

Amendment Lists are numbered consecutively and will be issued at regular intervals. This schedule is to be checked with the statement of Amendment Lists issued, which is published periodically by A.M.O.s.

15. SERIAL NUMBER

This schedule is Serial Numbered and is to be accounted for in accordance with A.M.O. A.772/47.

16. ASSOCIATED PUBLICATIONS

The following associated Schedules of Spare Parts for Airframe Accessory Equipment are to be used in conjunction with this schedule:—

A.P. 4515 B, C, F, G, R and S
Vol. 3, Part 1

17. CLASSIFICATION OF EQUIPMENT

The letters denoting the Class of Store are defined as follows:—

CLASS "A"—Class "A" items are those items of equipment which remain on charge and cannot be replaced except on return to store. Repairable items which are beyond the capacity or authority of the unit to repair are to be returned to the appropriate Maintenance Unit categorised R/D.

CLASS "B"—Class "B" items are those items of equipment which remain on charge and cannot be replaced except on return to store. Items which are beyond the capacity of the unit to repair, or which for technical reasons are not capable of being repaired whatever the defect are to be disposed of locally by units.

CLASS "C"—Class "C" items are items of equipment other than Class "A" or "B" which are consumable in use, or are incapable of being economically repaired and are not of a nature which would necessitate detailed accounting as Class "A" or "B" equipment.

MODIFICATION AND AMENDMENT SHEET
(Airframe)

Mod. No.	A.L. No.	Mod. No.	A.L. No.	Mod. No.	A.L. No.	Mod. No.	A.L. No.	Mod. No.	A.L. No.	Mod. No.	A.L. No.
1(M)	NA	29	NA	57(M)	‡	85(M)	‡	113	NA	141	NA
2(M)	‡	30	NA	58(M)	5	86(M)	NA	114	NA	142	NA
3(M)	‡	31	NA	59	C	87(M)	‡	115	NA	143	NA
4(M)	NA	32	NA	60	NA	88	C	116	NA	144	NA
5	NA	33	NA	61	NA	89(M)	‡	117	NA	145	NA
6	NA	34	NA	62(M)	NA	90(M)	‡	118	NA	146	NA
7	NA	35	NA	63(M)	‡	91	NA	119	NA	147	NA
8(M)	‡	36	NA	64	C	92	NA	120	NA	148	NA
9(M)	NA	37	NA	65	NA	93	C	121	NA	149	NA
10(M)	‡	38	NA	66(M)	NA	94	C	122	NA	150(M)	NA
11(M)	‡	39	NA	67(M)	‡	95(M)	2	123	NA	151	C
12(M)	‡	40	NA	68(M)	‡	96(M)	‡	124	NA	152(M)	NA
13	NA	41	NA	69(M)	NA	97(M)	NA	125	NA	153(M)	‡
14(M)	‡	42	NA	70	C	98(M)	NA	126	NA	154(M)	‡
15(M)	‡	43	NA	71(M)	‡	99(M)	NA	127	NA	155(M)	NA
16	NA	44	NA	72(M)	‡	100	NA	128	NA	156	NA
17	C	45	NA	73	NA	101	NA	129	NA	157(M)	NA
18(M)	‡	46	NA	74(M)	NA	102	NA	130	NA	158	C
19	NA	47	NA	75	NA	103	NA	131	NA	159(M)	‡
20	NA	48	NA	76	NA	104	NA	132	NA	160	C
21	NA	49	NA	77	NA	105	NA	133	NA	161(M)	NA
22	NA	50	NA	78(M)	‡	106	NA	134	NA	162	NA
23	NA	51(M)	‡	79(M)	‡	107	NA	135	NA	163(M)	NA
24	NA	52	C	80	NA	108	NA	136	NA	164(M)	NA
25	NA	53(M)	NA	81	NA	109	NA	137	NA	165(M)	‡
26	NA	54(M)	NA	82	NA	110	NA	138	NA	166	C
27	NA	55	NA	83(M)	NA	111	NA	139	NA	167	NA
28	NA	56(M)	‡	84	NA	112	NA	140	NA	168(M)	NA

‡ Incorporated in initial issue of Schedule.
 NA Modification/Amendment not applicable to this Schedule.
 C Modification/Amendment cancelled.
 (A) Amendment.
 (M) Modification.

MODIFICATION AND AMENDMENT SHEET
(Airframe)

Mod. No.	A.L. No.	Mod. No.	A.L. No.	Mod. No.	A.L. No.	Mod. No.	A.L. No.	Mod. No.	A.L. No.	Mod. No.	A.L. No.
169	NA	197(M)	NA	225	NA	253(M)	‡	281(M)	NA	309(M)	‡
170(M)	‡	198(M)	NA	226	NA	254	C	282	NA	310	NA
171(M)	‡	199(M)	‡	227	NA	255(M)	‡	283(M)	‡	311(M)	‡
172	C	200	NA	228	NA	256(M)	NA	284(M)	NA	312(M)	‡
173	C	201	NA	229	NA	257	NA	285(M)	‡	313(M)	‡
174(M)	‡	202	NA	230	NA	258(M)	‡	286(M)	NA	314(M)	NA
175(M)	‡	203	NA	231	NA	259(M)	‡	287	C	315(M)	‡
176(M)	‡	204	NA	232	NA	260(M)	NA	288	NA	316(M)	NA
177(M)	NA	205	NA	233	NA	261(M)	NA	289	NA	317(M)	5
178(M)	NA	206	NA	234	NA	262	NA	290	NA	318	
179(M)	‡	207	NA	235	NA	263	NA	291(M)	‡	319(M)	NA
180(M)	‡	208	NA	236	NA	264	NA	292(M)	‡	320(M)	‡
181(M)	NA	209	NA	237	NA	265(M)	‡	293(M)	NA	321(M)	NA
182(M)	‡	210	NA	238	NA	266(M)	‡	294(M)	‡	322(M)	‡
183(M)	‡	211	NA	239	NA	267(M)	‡	295(M)	NA	323(M)	‡
184(M)	NA	212	NA	240	NA	268(M)	NA	296(M)	‡	324(M)	NA
185(M)	‡	213	NA	241	NA	269(M)	2	297(M)	‡	325(M)	NA
186(M)	‡	214	NA	242	NA	270(M)	1	298	C	326	NA
187	NA	215	NA	243	NA	271(M)	‡	299(M)	‡	327(M)	NA
188(M)	‡	216	NA	244	NA	272(M)	3	300(M)	NA	328	A
189(M)	NA	217	NA	245	NA	273(M)	1	301	NA	329	NA
190	NA	218	NA	246	NA	274	C	302	NA	330(M)	NA
191(M)	‡	219	NA	247	NA	275(M)	‡	303(M)	NA	331	NA
192	C	220	NA	278	NA	276(M)	NA	304(M)	NA	332(M)	NA
193	NA	221	NA	249	NA	277(M)	NA	305(M)	‡	333	NA
194	NA	222	NA	250	NA	278(M)	NA	306	NA	334	A
195	NA	223	NA	251(M)	‡	279(M)	‡	307	NA	335	A
196(M)	‡	224	NA	252(M)	NA	280(M)	‡	308(M)	NA	336(M)	2

‡ Incorporated in initial issue of Schedule.
 NA Modification/Amendment not applicable to this Schedule.
 C Modification/Amendment cancelled.
 (A) Amendment
 (M) Modification

MODIFICATION AND AMENDMENT SHEET
(Airframe)

Mod. No.	A.L. No.	Mod. No.	A.L. No.	Mod. No.	A.L. No.	Mod. No.	A.L. No.	Mod. No.	A.L. No.	Mod. No.	A.L. No.
337(M)	‡	365	NA	393	NA	421(M)	NA	449(M)	NA	477	NA
338	C	366	NA	394	NA	422(M)	NA	450(M)	5	478	NA
339	‡	367	NA	395	NA	423	NA	451	NA	479	NA
340	‡	368	NA	396	NA	424(M)	‡	452	NA	480	NA
341	NA	369	NA	397	NA	425	C	453	NA	481	NA
342	NA	370	NA	398	NA	426(M)	‡	454	NA	482	NA
343(M)	NA	371	NA	399	NA	427	NA	455	NA	483	NA
344(M)	I	372	NA	400	NA	428(M)	NA	456	NA	484	NA
345(M)	‡	373	NA	401(M)	‡	429(M)	‡	457	NA	485	NA
346	NA	374	NA	402(M)	NA	430(M)	‡	458	NA	486	NA
347	‡	375	NA	403	NA	431(M)	C	459	NA	487	NA
348	C	376	NA	404	‡	432	NA	460	NA	488	NA
349	‡	377	NA	405(M)	NA	433(M)	‡	461	NA	489	NA
350	NA	378	NA	406(M)	NA	434(M)	NA	462	NA	490	NA
351	NA	379	NA	407	NA	435	C	463	NA	491	NA
352	NA	380	NA	408(M)	NA	436	C	464	NA	492	NA
353	NA	381	NA	409	NA	437	NA	465	NA	493(A)	‡
354	NA	382	NA	410(M)	‡	438(M)	NA	466	NA	494	NA
355	NA	383	NA	411	NA	439	NA	467	NA	495	NA
356	NA	384	NA	412	NA	440(M)	I	468	NA	496	NA
357	NA	385	NA	413(M)	NA	441	NA	469	NA	497	NA
358	NA	386	NA	414	NA	442(M)	NA	470	NA	498	NA
359	NA	387	NA	415	NA	443(M)	NA	471	NA	499	NA
360	NA	388	NA	416(M)	5	444(M)	NA	472	NA	500	NA
361	NA	389	NA	417	C	445(M)	‡	473	NA	501(M)	NA
362	NA	390	NA	418(M)	‡	446(M)	I	474	NA	502(M)	‡
363	NA	391	NA	419(M)	6	447	NA	475	NA	503(M)	NA
364	NA	392	NA	420	NA	448(M)	C	476	NA	504(M)	NA

‡ Incorporated in initial issue of Schedule.
 NA Modification/Amendment not applicable to this Schedule.
 C Modification/Amendment cancelled.
 (A) Amendment.
 (M) Modification.

MODIFICATION AND AMENDMENT SHEET
(Airframe)

Mod. No.	A.L. No.	Mod. No.	A.L. No.	Mod. No.	A.L. No.	Mod. No.	A.L. No.	Mod. No.	A.L. No.	Mod. No.	A.L. No.
505	NA	533(M)	6	561(A)	‡	589(A)	‡	617(M)	1	645(M)	6
506(M)	NA	534(M)	6	562	NA	590(A)	NA	618(M)	NA	646(M)	1
507(M)	NA	535(M)	1	563	NA	591	NA	619	C	647(M)	6
508(M)	NA	536(M)	NA	564	NA	592	NA	620(M)	A	648	NA
509(M)	‡	537(M)	‡	565	NA	593	NA	621(M)	‡	649(M)	6
510(M)	NA	538(M)	NA	566(A)	3	594	NA	622	A	650(M)	NA
511	NA	539(M)	C	567	NA	595	NA	623(M)	NA	651	NA
512(M)	‡	540	NA	568(A)	NA	596	NA	624	C	652	NA
513(M)	NA	541(M)	6	569(A)	‡	597	NA	625(M)	NA	653(A)	NA
514(M)	NA	542(M)	‡	570	NA	598	NA	626	NA	654	NA
515(M)	5	543(M)	1	571	NA	599(A)	5	627(M)	2	655(A)	‡
516(M)	‡	544	C	572	NA	600	NA	628	A	656	NA
517	NA	545	A	573	NA	601(M)	1	629(M)	NA	657(A)	‡
518	C	546	NA	574	NA	602	C	630(M)	1	658	NA
519(M)	18	547	A	575	NA	603(M)	5	631(M)	NA	659(A)	‡
520(M)	‡	548	NA	576(A)	NA	604	C	632(M)	2	660(A)	6
521(M)	1	549	6	577(A)	‡	605(M)	6	633(M)	C	661(A)	NA
522	C	550(M)	1	578	NA	606(M)	6	634(M)	C	662	NA
523(M)	6	551	NA	579	NA	607(M)	NA	635(M)	6	663(A)	‡
524(M)	C	552	NA	580	NA	608(M)	2	636(M)	3	664	NA
525(M)	NA	553	NA	581(A)	NA	609	C	637(M)	NA	665(A)	NA
526	C	554	NA	582	NA	610(M)	1	638(M)	1	666(A)	‡
527(M)	‡	555(A)	NA	583	NA	611	NA	639(M)	5	667(A)	‡
528(M)	‡	556	NA	584	NA	612	6	640	A	668	NA
529	C	557	NA	585(A)	‡	613(M)	6	641(M)	1	669(A)	NA
530	NA	558	NA	586	NA	614(M)	C	642(M)	3	670	NA
531(M)	NA	559	NA	587	NA	615	C	643(M)	5	671(A)	‡
532(M)	C	560	NA	588(A)	‡	616	NA	644(M)	2	672(A)	NA

‡ Incorporated in initial issue of Schedule.
 NA Modification/Amendment not applicable to this Schedule.
 C Modification/Amendment cancelled.
 (A) Amendment
 (M) Modification

MODIFICATION AND AMENDMENT SHEET
(Airframe)

Mod. No.	A.L. No.	Mod. No.	A.L. No.	Mod. No.	A.L. No.	Mod. No.	A.L. No.	Mod. No.	A.L. No.	Mod. No.	A.L. No.
673	NA	701	NA	729	NA	757(A)	NA	785	NA	813(A)	NA
674	NA	702	NA	730	NA	758(A)	NA	786(A)	NA	814(A)	1
675(A)	1	703	NA	731	NA	759(A)	‡	787	NA	815(A)	NA
676(A)	NA	704(M)	6	732	NA	760(A)	NA	788(A)	2	816(A)	6
677	NA	705(M)	C	733(M)	6	761	NA	789(A)	6	817(A)	2
678(A)	NA	706	NA	734(M)	6	762(A)	‡	790(A)	6	818(A)	NA
679(A)	NA	707(M)	NA	735(M)	NA	763	NA	791(A)	6	819(A)	5
680	NA	708(M)	NA	736	NA	764(A)	‡	792	NA	820(A)	NA
681(A)	NA	709(M)	1	737(M)	5	765	NA	793(A)	NA	821(A)	1
682(A)	‡	710	NA	738(M)	5	766	NA	794(A)	2	822	NA
683(A)	‡	711(M)	6	739	NA	767	NA	795(A)	6	823(A)	2
684	NA	712(M)	1	740(M)	NA	768	NA	796(A)	NA	824(A)	NA
685	NA	713	NA	741	NA	769(A)	3	797(A)	6	825(A)	NA
686	NA	714(M)	4	742	NA	770(A)	NA	798(A)	6	826(A)	6
687	NA	715	NA	743(M)	2	771	NA	799(A)	6	827(A)	3
688(A)	‡	716(M)	5	744(M)	2	772	NA	800(A)	2	828(A)	NA
689	NA	717	NA	745(M)	4	773(A)	6	801(A)	2	829	NA
690	NA	718	NA	746	C	774	NA	802(A)	6	830(A)	2
691(A)	NA	719	C	747(M)	6	775(A)	6	803(A)	NA	831(A)	6
692	NA	720	A	748(M)	1	776(A)	2	804(A)	NA	832(A)	NA
693	NA	721	NA	749(M)	1	777	NA	805(A)	NA	833(A)	NA
694(A)	‡	722	NA	750(M)	NA	778(A)	NA	806(A)	5	834(A)	NA
695(A)	2	723	NA	751(M)	NA	779(A)	NA	807(A)	NA	835(A)	NA
696(A)	NA	724(M)	NA	752(A)	6	780	NA	808(A)	6	836(A)	3
697	NA	725	C	753(A)	‡	781(A)	NA	809(A)	6	837(A)	1
698(A)	NA	726(M)	2	754	NA	782(A)	NA	810(A)	2	838	NA
699(A)	NA	727(M)	2	755	NA	783(A)	2	811(A)	NA	839(A)	NA
700(A)	NA	728(M)	2	756	NA	784(A)	NA	812(A)	NA	840(A)	6

‡ Incorporated in initial issue of Schedule.
 NA Modification/Amendment not applicable to this Schedule.
 C Modification/Amendment cancelled.
 (A) Amendment.
 (M) Modification.

MODIFICATION AND AMENDMENT SHEET
(Airframe)

Mod. No.	A.L. No.	Mod. No.	A.L. No.	Mod. No.	A.L. No.	Mod. No.	A.L. No.	Mod. No.	A.L. No.	Mod. No.	A.L. No.
841	NA	869(M)	6	897	NA	925	NA	953(A)	6	981	NA
842(A)	NA	870(M)	C	898	NA	926(A)	NA	954(A)	NA	982(A)	NA
843	NA	871	NA	899(M)	NA	927(A)	NA	955(A)	NA	983(A)	NA
844(A)	3	872	NA	900(M)	6	928(A)	NA	956(A)	NA	984(A)	NA
845(A)	NA	873	C	901(A)	6	929(A)	NA	957(A)	6	985(A)	NA
846(A)	2	874(M)	5	902(A)	2	930(A)	NA	958(A)	6	986(A)	NA
847(A)	NA	875(M)	4	903(A)	NA	931(A)	NA	959(A)	3	987(A)	NA
848(A)	NA	876	18	904(A)	NA	932(A)	NA	960(A)	2	988(A)	NA
849	NA	877(M)	5	905(A)	NA	933(A)	NA	961(A)	NA	989(A)	NA
850(A)	NA	878(M)	2	906(A)	NA	934(A)	6	962(A)	6	990(A)	6
851(M)	NA	879(M)	C	907(A)	A	935(A)	6	963(A)	6	991(A)	6
852(M)	2	880(M)	4	908(A)	3	936(A)	NA	964(A)	NA	992(A)	NA
853(M)	6	881	NA	909(A)	NA	937(A)	NA	965(A)	NA	993(A)	NA
854	NA	882	NA	910	NA	938(A)	NA	966(A)	2	994(A)	6
855	NA	883	NA	911(A)	2	939(A)	NA	967(A)	NA	995(A)	NA
856(M)	5	884	NA	912(A)	NA	940(A)	NA	968(A)	6	996	NA
857(M)	6	885(M)	NA	913(A)	NA	941(A)	NA	969(A)	NA	997(A)	6
858(M)	6	886(M)	3	914(A)	4	942(A)	NA	970(A)	6	998(A)	NA
859(M)	5	887	NA	915	NA	943(A)	2	971(A)	NA	999(A)	6
860(M)	5	888(M)	5	916(A)	NA	944(A)	4	972	NA	1000(A)	NA
861	NA	889(M)	6	917(A)	NA	945(A)	NA	973(A)	NA	1001	NA
862(M)	3	890	NA	918	NA	946(A)	NA	974(A)	NA	1002(M)	NA
863(M)	2	891(M)	NA	919(A)	NA	947(A)	NA	975(A)	6	1003	NA
864(M)	NA	892	C	920(A)	2	948(A)	6	976(A)	6	1004	NA
865(M)	3	893	C	921	NA	949	NA	977(A)	6	1005	
866(M)	5	894(M)	2	922(A)	NA	950(A)	NA	978(A)	NA	1006	C
867(M)	2	895(M)	4	923(A)	NA	951(M)	NA	979(A)	2	1007(M)	5
868(M)	NA	896	NA	924(A)	2	952(A)	6	980(A)	6	1008(M)	3

‡ Incorporated in initial issue of Schedule.
 NA Modification/Amendment not applicable to this Schedule.
 C Modification/Amendment cancelled.
 (A) Amendment.
 (M) Modification

MODIFICATION AND AMENDMENT SHEET
(Airframe)

Mod. No.	A.L. No.	Mod. No.	A.L. No.	Mod. No.	A.L. No.	Mod. No.	A.L. No.	Mod. No.	A.L. No.	Mod. No.	A.L. No.
1009	NA	1037(M)	C	1065(A)	NA	1093(A)	NA	1121(A)	NA	1149	NA
1010(M)	6	1038	NA	1066(A)	6	1094(A)	NA	1122(A)	NA	1150(A)	NA
1011	NA	1039	NA	1067(A)	NA	1095(A)	NA	1123(A)	5	1151(M)	NA
1012	NA	1040(M)	NA	1068(A)	6	1096(A)	6	1124(A)	6	1152(M)	NA
1013	NA	1041(M)	NA	1069(A)	NA	1097(A)	NA	1125	NA	1153	NA
1014	NA	1042(M)	C	1070(A)	NA	1098(A)	5	1126	NA	1154	NA
1015	NA	1043	NA	1071(A)	NA	1099(A)	NA	1127	NA	1155(M)	6
1016	NA	1044(M)	NA	1072(A)	NA	1100(A)	NA	1128(A)	NA	1156(M)	5
1017(M)	6	1045(M)	NA	1073(A)	NA	1101(A)	NA	1129	NA	1157	A
1018	NA	1046(M)	NA	1074(A)	NA	1102(A)	NA	1130(A)	NA	1158	NA
1019	C	1047	NA	1075(A)	NA	1103(A)	NA	1131(A)	NA	1159(M)	NA
1020	NA	1048(M)	6	1076(A)	NA	1104(A)	NA	1132(A)	NA	1160(M)	4
1021(M)	3	1049	NA	1077(A)	NA	1105(A)	NA	1133(A)	NA	1161	NA
1022(M)	NA	1050(M)	NA	1078(A)	NA	1106(A)	6	1134(A)	NA	1162	NA
1023(M)	NA	1051(A)	NA	1079(A)	6	1107(A)	NA	1135(A)	NA	1163	NA
1024(M)	NA	1052(A)	NA	1080(A)	NA	1108(A)	3	1136(A)	NA	1164(M)	A
1025(M)	13	1053(A)	NA	1081(A)	NA	1109(A)	NA	1137(A)	NA	1165(M)	6
1026	NA	1054(A)	NA	1082(A)	NA	1110(A)	NA	1138(A)	NA	1166	C
1027(M)	3	1055(A)	NA	1083(A)	NA	1111(A)	NA	1139(A)	NA	1167	C
1028(M)	4	1056(A)	NA	1084(A)	NA	1112(A)	NA	1140(A)	NA	1168	NA
1029	NA	1057(A)	6	1085(A)	NA	1113(A)	NA	1141(A)	NA	1169	NA
1030	NA	1058(A)	6	1086(A)	6	1114(A)	NA	1142(A)	NA	1170(M)	6
1031	C	1059(A)	NA	1087(A)	NA	1115(A)	NA	1143(A)	6	1171(M)	5
1032	C	1060(A)	NA	1088(A)	NA	1116(A)	5	1144(A)	NA	1172	C
1033(M)	5	1061(A)	NA	1089	NA	1117(A)	NA	1145(A)	NA	1173	NA
1034(M)	6	1062(A)	NA	1090(A)	NA	1118(A)	NA	1146(A)	NA	1174	NA
1035	C	1063	NA	1091(A)	NA	1119(A)	NA	1147(A)	NA	1175(M)	A
1036(M)	6	1064(A)	NA	1092(A)	NA	1120(A)	NA	1148(A)	NA	1176(M)	5

‡ Incorporated in initial issue of Schedule.
 NA Modification/Amendment not applicable to this Schedule.
 C Modification/Amendment cancelled.
 (A) Amendment.
 (M) Modification.

MODIFICATION AND AMENDMENT SHEET
(Airframe)

Mod. No.	A.L. No.	Mod. No.	A.L. No.	Mod. No.	A.L. No.	Mod. No.	A.L. No.	Mod. No.	A.L. No.	Mod. No.	A.L. No.
1177	NA	1205(A)	NA	1233	NA	1261(M)	A	1289	A	1317(A)	NA
1178	NA	1206(A)	NA	1234(A)	NA	1262	NA	1290(M)	NA	1318(A)	NA
1179	NA	1207(A)	NA	1235(A)	NA	1263	NA	1291	NA	1319(A)	NA
1180	NA	1208(A)	NA	1236(A)	NA	1264	NA	1292	NA	1320(A)	NA
1181	NA	1209(A)	NA	1237(A)	NA	1265	NA	1293	NA	1321(A)	NA
1182	NA	1210(A)	NA	1238(A)	5	1266(M)	15	1294(M)	12	1322(A)	NA
1183	NA	1211(A)	NA	1239(A)	NA	1267	NA	1295	NA	1323(A)	NA
1184	NA	1212(A)	NA	1240	NA	1268(M)	NA	1296	NA	1324(A)	NA
1185	NA	1213(A)	NA	1241(A)	NA	1269(M)	C	1297	NA	1325(A)	NA
1186	NA	1214(A)	NA	1242	NA	1270	NA	1298	NA	1326(A)	NA
1187	NA	1215(A)	NA	1243(A)	NA	1271(M)	A	1299	NA	1327(A)	NA
1188	NA	1216(A)	NA	1244(A)	NA	1272	NA	1300	NA	1328(A)	NA
1189	NA	1217(A)	NA	1245(A)	6	1273(M)	13	1301(A)	NA	1329(A)	NA
1190	NA	1218(A)	NA	1246(A)	NA	1274(M)	6	1302(A)	NA	1330(A)	NA
1191	NA	1219(A)	NA	1247(A)	NA	1275(M)	A	1303(A)	NA	1331	NA
1192	C	1220(A)	NA	1248(A)	NA	1276(M)	5	1304(A)	6	1332(A)	NA
1193	C	1221(A)	NA	1249(A)	NA	1277(M)	13	1305(A)	NA	1333(A)	NA
1194	C	1222(A)	4	1250(A)	NA	1278(M)	A	1306(A)	6	1334(A)	A
1195	NA	1223(A)	NA	1251(M)	6	1279	C	1307(A)	NA	1335	NA
1196(M)	5	1224(A)	NA	1252	NA	1280	NA	1308(A)	NA	1336(A)	A
1197(M)	NA	1225(A)	NA	1253	NA	1281	NA	1309(A)	NA	1337(A)	NA
1198	NA	1226(A)	NA	1254(M)	A	1282(M)	A	1310(A)	NA	1338(A)	NA
1199	NA	1227(A)	NA	1255	NA	1283(M)	NA	1311(A)	NA	1339(A)	NA
1200(M)	A	1228(A)	NA	1256	NA	1284	18	1312(A)	NA	1340(A)	NA
1201(A)	NA	1229(A)	NA	1257	NA	1285	C	1313(A)	NA	1341(A)	NA
1202(A)	NA	1230(A)	NA	1258	NA	1286(M)	NA	1314(A)	NA	1342(A)	5
1203(A)	5	1231(A)	NA	1259(M)	NA	1287(M)	A	1315(A)	NA	1343(A)	A
1204(A)	NA	1232(A)	NA	1260	NA	1288(M)	NA	1316(A)	6	1344(A)	NA

‡ Incorporated in initial issue of Schedule.
 NA Modification/Amendment not applicable to this Schedule.
 C Modification/Amendment cancelled.
 (A) Amendment.
 (M) Modification

MODIFICATION AND AMENDMENT SHEET
(Airframe)

Mod. No.	A.L. No.	Mod. No.	A.L. No.	Mod. No.	A.L. No.	Mod. No.	A.L. No.	Mod. No.	A.L. No.	Mod. No.	A.L. No.
1345(A)	NA	1373(A)	NA	1401(M)	NA	1429	C	1457(M)	A	1485	NA
1346(A)	NA	1374(A)	A	1402	NA	1430	NA	1458(M)	NA	1486	NA
1347(A)	NA	1375(A)	NA	1403	NA	1431(M)	12	1459	NA	1487	NA
1348(A)	NA	1376(A)	NA	1404(M)	A	1432(M)	NA	1460(M)	NA	1488	NA
1349(A)	A	1377(A)	NA	1405(M)	12	1433(M)	A	1461	NA	1489(M)	9
1350(A)	A	1378(A)	NA	1406(M)	A	1434(M)	A	1462(M)	A	1490	NA
1351(A)	NA	1379(A)	A	1407	NA	1435	NA	1463	NA	1491	NA
1352(A)	NA	1380(A)	NA	1408	NA	1436		1464(M)	A	1492	NA
1353(A)	NA	1381	NA	1409(M)	C	1437	A	1465(M)	A	1493	NA
1354(A)	A	1382(A)	NA	1410(M)	C	1438	NA	1466(M)	NA	1494(M)	NA
1355(A)	NA	1383(A)	NA	1411(M)	A	1439(M)	A	1467	NA	1495(M)	13
1356	NA	1384	NA	1412	NA	1440	NA	1468	NA	1496(M)	13
1357(A)	NA	1385(A)	NA	1413	NA	1441	NA	1469	NA	1497(M)	9
1358(A)	NA	1386(A)	A	1414	NA	1442	NA	1470(M)	12	1498(M)	A
1359(A)	NA	1387(A)	NA	1415	C	1443	NA	1471	NA	1499	NA
1360(A)	NA	1388	NA	1416	NA	1444	NA	1472	NA	1500	NA
1361(A)	NA	1389(A)	NA	1417	C	1445	NA	1473	NA	1501	NA
1362(A)	NA	1390(A)	NA	1418(M)	NA	1446	NA	1474	NA	1502	NA
1363(A)	NA	1391(A)	NA	1419	C	1447	NA	1475	C	1503	NA
1364(A)	NA	1392(A)	NA	1420	NA	1448	C	1476	NA	1504	NA
1365(A)	NA	1393(A)	NA	1421(M)	NA	1449	NA	1477(M)	A	1505	NA
1366(A)	NA	1394(A)	NA	1422(M)	A	1450(M)	NA	1478	NA	1506	NA
1367(A)	NA	1395(A)	NA	1423(M)	NA	1451(M)	A	1479(M)	NA	1507	NA
1368(A)	NA	1396	NA	1424(M)	NA	1452(M)	A	1480	NA	1508	NA
1369(A)	NA	1397(A)	NA	1425	NA	1453(M)	NA	1481(M)		1509	NA
1370	NA	1398(A)	NA	1426(M)	9	1454	NA	1482	NA	1510	NA
1371(A)	NA	1399(A)	NA	1427(M)	12	1455	NA	1483(M)	NA	1511	NA
1372(A)	NA	1400	NA	1428(M)	NA	1456(M)	NA	1484(M)	A	1512	NA

‡ Incorporated in initial issue of Schedule.
 NA Modification/Amendment not applicable to this Schedule.
 C Modification/Amendment cancelled.
 (A) Amendment.
 (M) Modification.

MODIFICATION AND AMENDMENT SHEET
(Airframe)

Mod. No.	A.L. No.	Mod. No.	A.L. No.	Mod. No.	A.L. No.	Mod. No.	A.L. No.	Mod. No.	A.L. No.	Mod. No.	A.L. No.
1513	NA	1541	NA	1569	NA	1597	NA	1625(A)	NA	1653(A)	A
1514	NA	1542	NA	1570	NA	1598	NA	1626(A)	A	1654(A)	NA
1515	NA	1543	NA	1571	NA	1599	NA	1627(A)	A	1655(A)	A
1516	NA	1544	NA	1572	NA	1600	NA	1628(A)	A	1656	NA
1517	NA	1545	NA	1573	NA	1601	NA	1629(A)	A	1657(A)	A
1518	NA	1546	NA	1574	NA	1602(A)	NA	1630	NA	1658(A)	A
1519	NA	1547	NA	1575	NA	1603(A)	A	1631(A)	NA	1659(A)	NA
1520	NA	1548	NA	1576	NA	1604(A)	6	1632(A)	A	1660(A)	A
1521	NA	1549	NA	1577	NA	1605(A)	A	1633(A)	NA	1661	NA
1522	NA	1550	NA	1578	NA	1606(A)	NA	1634(A)	A	1662	NA
1523	NA	1551	NA	1579	NA	1607(A)	NA	1635(A)	A	1663(A)	NA
1524	NA	1552	NA	1580	NA	1608	NA	1636(A)	NA	1664(A)	NA
1525	NA	1553	NA	1581	NA	1609(A)	A	1637(A)	NA	1665(A)	NA
1526	NA	1554	NA	1582	NA	1610(A)	NA	1638(A)	NA	1666(A)	NA
1527	NA	1555	NA	1583	NA	1611(A)	NA	1639(A)	NA	1667(A)	NA
1528	NA	1556	NA	1584	NA	1612	NA	1640	NA	1668(A)	A
1529	NA	1557	NA	1585	NA	1613(A)	NA	1641(A)	NA	1669(A)	NA
1530	NA	1558	NA	1586	NA	1614(A)	NA	1642(A)	NA	1670	NA
1531	NA	1559	NA	1587	NA	1615(A)	NA	1643(A)	NA	1671(A)	NA
1532	NA	1560	NA	1588	NA	1616	NA	1644(A)	NA	1672(A)	NA
1533	NA	1561	NA	1589	NA	1617(A)	NA	1645(A)	NA	1673(A)	NA
1534	NA	1562	NA	1590	NA	1618(A)	NA	1646(A)	A	1674(A)	NA
1535	NA	1563	NA	1591	NA	1619(A)	NA	1647	NA	1675(A)	NA
1536	NA	1564	NA	1592	NA	1620(A)	NA	1648(A)	NA	1676	NA
1537	NA	1565	NA	1593	NA	1621(A)	NA	1649(A)	NA	1677(A)	NA
1538	NA	1566	NA	1594	NA	1622(A)	NA	1650(A)	NA	1678(A)	A
1539	NA	1567	NA	1595	NA	1623	NA	1651(A)	NA	1679(A)	NA
1540	NA	1568	NA	1596	NA	1624(A)	NA	1652(A)	A	1680(A)	A

‡ Incorporated in initial issue of Schedule.
 NA Modification/Amendment not applicable to this Schedule.
 C Modification/Amendment cancelled.
 (A) Amendment.
 (M) Modification

MODIFICATION AND AMENDMENT SHEET
(Airframe)

Mod. No.	A.L. No.	Mod. No.	A.L. No.	Mod. No.	A.L. No.	Mod. No.	A.L. No.	Mod. No.	A.L. No.	Mod. No.	A.L. No.
1681(A)	A	1709	18	1737(M)	NA	1765	NA	1793	NA	1821(A)	A
1682	NA	1710	C	1738	NA	1766	NA	1794	NA	1822(A)	NA
1683	NA	1711	C	1739	NA	1767	NA	1795	NA	1823(A)	NA
1684	A	1712(M)	12	1740(M)	A	1768	NA	1796	NA	1824(A)	NA
1685(A)	NA	1713(M)	A	1741	C	1769	NA	1797	NA	1825(A)	NA
1686(A)	NA	1714(M)	A	1742	NA	1770	C	1798	NA	1826(A)	NA
1687(A)	NA	1715	NA	1743	NA	1771(M)	NA	1799	NA	1827(A)	NA
1688(A)	A	1716(M)	NA	1744	NA	1772	C	1800	C	1828(A)	A
1689(A)	NA	1717	C	1745	NA	1773	NA	1801(A)	A	1829(A)	A
1690(A)	A	1718	C	1746	C	1774		1802(A)	NA	1830(A)	NA
1691(A)	NA	1719	C	1747(M)	A	1775	C	1803(A)	NA	1831(A)	NA
1692(A)	NA	1720(M)	NA	1748	NA	1776	C	1804(A)	NA	1832(A)	NA
1693(A)	A	1721(M)	A	1749	C	1777	C	1805	NA	1833(A)	NA
1694(A)	NA	1722(M)	NA	1750(M)	NA	1778	NA	1806(A)	NA	1834(A)	NA
1695(A)	A	1723	NA	1751	NA	1779	C	1807(A)	A	1835(A)	NA
1696(A)	NA	1724(M)	A	1752	NA	1780	C	1808(A)	NA	1836(A)	NA
1697(A)	NA	1725(M)	A	1753	NA	1781	NA	1809(A)	A	1837	NA
1698(A)	A	1726	NA	1754	NA	1782	NA	1810(A)	A	1838(A)	NA
1699(A)	A	1727	NA	1755	NA	1783(M)	NA	1811(A)	A	1839(A)	NA
1700(A)	NA	1728	NA	1756	NA	1784	NA	1812(A)	A	1840(A)	NA
1701	NA	1729	C	1757	NA	1785	C	1813(A)	NA	1841	NA
1702	NA	1730	NA	1758	NA	1786	NA	1814(A)	NA	1842(A)	NA
1703	NA	1731(M)	A	1759	NA	1787	NA	1815(A)	NA	1843	NA
1704	NA	1732(M)	NA	1760	NA	1788	NA	1816(A)	NA	1844(A)	NA
1705(M)	A	1733	NA	1761	NA	1789	NA	1817(A)	A	1845(A)	NA
1706	NA	1734(M)	A	1762	NA	1790	NA	1818(A)	NA	1846(A)	NA
1707(M)	12	1735(M)	NA	1763	NA	1791	NA	1819(A)	NA	1847(A)	A
1708	15	1736	NA	1764	NA	1792	NA	1820	NA	1848(A)	A

‡ Incorporated in initial issue of Schedule.
 NA Modification/Amendment not applicable to this Schedule.
 C Modification/Amendment cancelled.
 (A) Amendment.
 (M) Modification.

MODIFICATION AND AMENDMENT SHEET
(Airframe)

Mod. No.	A.L. No.	Mod. No.	A.L. No.	Mod. No.	A.L. No.	Mod. No.	A.L. No.	Mod. No.	A.L. No.	Mod. No.	A.L. No.
1849	NA	1877(A)	NA	1905	18	1933	NA	1961	NA	1989(M)	C
1850(A)	NA	1878(A)	NA	1906	NA	1934(M)	NA	1962	NA	1990(M)	A
1851(A)	NA	1879(A)	NA	1907	NA	1935	NA	1963	NA	1991	C
1852	NA	1880(A)	NA	1908	NA	1936	NA	1964	C	1992	C
1853(A)	A	1881(A)	NA	1909	NA	1937	NA	1965	C	1993(M)	NA
1854(A)	A	1882(A)	NA	1910	NA	1938	NA	1966	NA	1994	C
1855(A)	A	1883(A)	NA	1911(M)	A	1939	NA	1967	NA	1995(M)	NA
1856(A)	NA	1884	NA	1912(M)	A	1940	NA	1968	NA	1996	NA
1857(A)	NA	1885(A)	NA	1913	NA	1941	C	1969	NA	1997(M)	NA
1858	NA	1886(A)	NA	1914	C	1942	C	1970	NA	1998	C
1859(A)	NA	1887(A)	NA	1915	NA	1943	C	1971	NA	1999	18
1860(A)	NA	1888(A)	NA	1916	NA	1944	NA	1972	C	2000	
1861(A)	NA	1889(A)	NA	1917	NA	1945(M)	NA	1973(M)	A	2001(A)	NA
1862(A)	NA	1890(A)	NA	1918(M)	NA	1946	NA	1974	NA	2002(A)	NA
1863(A)	NA	1891(A)	NA	1919	NA	1947	NA	1975	NA	2003(A)	NA
1864(A)	NA	1892(A)	NA	1920	NA	1948	NA	1976	C	2004(A)	NA
1865(A)	NA	1893(A)	NA	1921(M)	NA	1949	C	1977	NA	2005(A)	NA
1866(A)	NA	1894(A)	NA	1922	NA	1950	NA	1978	NA	2006(A)	NA
1867(A)	NA	1895(A)	NA	1923	NA	1951	NA	1979	C	2007(A)	NA
1868(A)	NA	1896(A)	NA	1924(M)	NA	1952	C	1980	C	2008(A)	NA
1869(A)	A	1897(A)	NA	1925(M)	A	1953	C	1981(M)	A	2009	NA
1870(A)	NA	1898(A)	NA	1926	NA	1954	NA	1982	NA	2010(A)	NA
1871(A)	NA	1899	NA	1927	NA	1955	NA	1983	NA	2011(A)	NA
1872(A)	NA	1900(A)	NA	1928	NA	1956	NA	1984	C	2012(A)	NA
1873(A)	NA	1901	NA	1929	NA	1957	NA	1985(M)	NA	2013(A)	NA
1874(A)	NA	1902	NA	1930	NA	1958(M)	A	1986	C	2014(A)	A
1875	NA	1903		1931	NA	1959	C	1987	C	2015(A)	A
1876(A)	NA	1904(M)	A	1932(M)	A	1960(M)	A	1988	C	2016	NA

‡ Incorporated in initial issue of Schedule.
 NA Modification/Amendment not applicable to this Schedule.
 C Modification/Amendment cancelled.
 (A) Amendment.
 (M) Modification

MODIFICATION AND AMENDMENT SHEET
(Airframe)

Mod. No.	A.L. No.	Mod. No.	A.L. No.	Mod. No.	A.L. No.	Mod. No.	A.L. No.	Mod. No.	A.L. No.	Mod. No.	A.L. No.
2017(A)	NA	2045(A)	NA	2073(A)	NA	2101	C	2129	NA	2157	C
2018(A)	NA	2046(A)	NA	2074(A)	NA	2102	NA	2130	C	2158(M)	NA
2019	NA	2047(A)	NA	2075(A)	A	2103	NA	2131	C	2159(M)	A
2020(A)	NA	2048(A)	NA	2076(A)	NA	2104	NA	2132(M)	A	2160(M)	A
2021(A)	NA	2049(A)	NA	2077(A)	NA	2105	NA	2133(M)	NA	2161	NA
2022(A)	A	2050	NA	2078(A)	A	2106	C	2134(M)	A	2162	C
2023(A)	A	2051	NA	2079(A)	NA	2107(M)	13	2135	NA	2163	C
2024(A)	NA	2052(A)	NA	2080(A)	NA	2108(M)	A	2136	NA	2164	C
2025(A)	NA	2053(A)	A	2081	NA	2109	NA	2137	C	2165	C
2026(A)	NA	2054(A)	NA	2082(A)	NA	2110	C	2138	C	2166	NA
2027	NA	2055(A)	NA	2083(A)	NA	2111	C	2139	C	2167	NA
2028(A)	NA	2056(A)	NA	2084(A)	NA	2112	C	2140	C	2168	C
2029(A)	NA	2057(A)	NA	2085(A)	NA	2113	C	2141	C	2169	C
2030	NA	2058(A)	A	2086	NA	2114	C	2142	NA	2170	C
2031(A)	NA	2059(A)	NA	2087(A)	NA	2115	C	2143	NA	2171	NA
2032(A)	NA	2060(A)	NA	2088(A)	NA	2116	C	2144	NA	2172	20
2033(A)	NA	2061	NA	2089(A)	A	2117	C	2145	C	2173	20
2034(A)	NA	2062(A)	NA	2090(A)	NA	2118	C	2146	NA	2174	NA
2035(A)	NA	2063(A)	A	2091(A)	NA	2119	C	2147	NA	2175	C
2036(A)	NA	2064	NA	2092(A)	NA	2120	C	2148(M)	18	2176	NA
2037(A)	NA	2065(A)	NA	2093(A)	A	2121	NA	2149	NA	2177	NA
2038(A)	NA	2066(A)	NA	2094	NA	2122	C	2150	NA	2178	NA
2039(A)	NA	2067(A)	NA	2095	NA	2123(M)	A	2151(M)	A	2179	NA
2040(A)	A	2068	NA	2096(A)	NA	2124	C	2152	C	2180	NA
2041(A)	NA	2069(A)	A	2097(A)	NA	2125	NA	2153	C	2181	NA
2042(A)	NA	2070	NA	2098(A)	A	2126	NA	2154	NA	2182	NA
2043(A)	NA	2071(A)	NA	2099(A)	NA	2127	NA	2155	NA	2183	
2044	NA	2072(A)	NA	2100(A)	NA	2128	NA	2156	NA	2184	NA

‡ Incorporated in initial issue of Schedule.
 NA Modification/Amendment not applicable to this Schedule.
 C Modification/Amendment cancelled.
 (A) Amendment.
 (M) Modification.

MODIFICATION AND AMENDMENT SHEET
(Airframe)

Mod. No.	A.L. No.	Mod. No.	A.L. No.	Mod. No.	A.L. No.	Mod. No.	A.L. No.	Mod. No.	A.L. No.	Mod. No.	A.L. No.
2185	C	2213(A)	NA	2241	NA	2269	NA	2297	NA	2325	NA
2186	NA	2214(A)	NA	2242(A)	NA	2270	NA	2298	A	2326	NA
2187(M)	12	2215(A)	NA	2243(A)	NA	2271	NA	2299	NA	2327	NA
2188	NA	2216	NA	2244(A)	NA	2272	NA	2300	NA	2328	C
2189(M)	A	2217(A)	NA	2245(A)	NA	2273	NA	2301(M)	A	2329	NA
2190	C	2218(A)	A	2246(A)	A	2274	NA	2302	NA	2330	NA
2191	NA	2219(A)	NA	2247(A)	A	2275	NA	2303	NA	2331	NA
2192(M)	NA	2220(A)	A	2248	NA	2276	NA	2304	NA	2332	C
2193	NA	2221(A)	A	2249	NA	2277	NA	2305	NA	2333	NA
2194	NA	2222(A)	NA	2250(A)	NA	2278	NA	2306(M)	A	2334	A
2195	NA	2223(A)	NA	2251	NA	2279	NA	2307	C	2335(M)	A
2196	NA	2224	NA	2252	NA	2280	NA	2308(M)	A	2336	C
2197	NA	2225(A)	NA	2253	NA	2281	NA	2309	NA	2337	C
2198	NA	2226(A)	NA	2254	NA	2282	NA	2310		2338	C
2199	NA	2227(A)	NA	2255	NA	2283	NA	2311(M)	A	2339	NA
2200	NA	2228(A)	NA	2256	NA	2284	NA	2312	NA	2340	
2201(A)	NA	2229(A)	NA	2257	NA	2285	NA	2313	C	2341	C
2202(A)	NA	2230(A)	NA	2258	NA	2286	NA	2314	C	2342	NA
2203(A)	NA	2231(A)	NA	2259	NA	2287	NA	2315	NA	2343	C
2204(A)	A	2232(A)	NA	2260	NA	2288	NA	2316	NA	2344	C
2205(A)	NA	2233(A)	A	2261	NA	2289	NA	2317	NA	2345	C
2206(A)	NA	2234(A)	A	2262	NA	2290	NA	2318(M)	A	2346	C
2207(A)	NA	2235	NA	2263	NA	2291	NA	2319	NA	2347(M)	A
2208(A)	A	2236	NA	2264	NA	2292	NA	2320	NA	2348	NA
2209(A)	NA	2237	NA	2265	NA	2293	NA	2321	NA	2349	C
2210(A)	NA	2238	NA	2266	NA	2294	NA	2322	NA	2350	NA
2211(A)	NA	2239(A)	NA	2267	NA	2295	NA	2323		2351	C
2212(A)	NA	2240(A)	NA	2268	NA	2296	NA	2324	NA	2352	C

‡ Incorporated in initial issue of Schedule.
 NA Modification/Amendment not applicable to this Schedule.
 C Modification/Amendment cancelled.
 (A) Amendment.
 (M) Modification

MODIFICATION AND AMENDMENT SHEET
(Airframe)

Mod. No.	A.L. No.	Mod. No.	A.L. No.	Mod. No.	A.L. No.	Mod. No.	A.L. No.	Mod. No.	A.L. No.	Mod. No.	A.L. No.
2353(M)	NA	2381	C	2409	NA	2437	NA	2465	NA	2493	NA
2354	C	2382	C	2410	NA	2438	NA	2466	NA	2494	NA
2355	15	2383	NA	2411	NA	2439	NA	2467	NA	2495	NA
2356	NA	2384	NA	2412(A)	NA	2440	NA	2468	NA	2496	NA
2357	C	2385	NA	2413	NA	2441	NA	2469	NA	2497	NA
2358	NA	2386(M)	NA	2414	NA	2442	NA	2470	NA	2498	NA
2359		2387	C	2415	NA	2443	NA	2471	NA	2499	NA
2360	NA	2388	NA	2416(A)	NA	2444	NA	2472	NA	2500	NA
2361(M)	A	2389	C	2417	NA	2445	NA	2473	NA	2501	18
2362	NA	2390	NA	2418	NA	2446	NA	2474	NA	2502	15
2363	NA	2391	NA	2419(A)	NA	2447	NA	2475	NA	2503(M)	NA
2364	NA	2392	20	2420	NA	2448	NA	2476	NA	2504	NA
2365	C	2393	NA	2421	NA	2449	NA	2477	NA	2505	NA
2366	C	2394(M)	NA	2422	NA	2450	NA	2478	NA	2506	NA
2367	NA	2395(M)	A	2423	NA	2451	NA	2479	NA	2507	NA
2368	NA	2396	NA	2424	NA	2452	NA	2480	NA	2508	NA
2369		2397	NA	2425	NA	2453	NA	2481	NA	2509	NA
2370	NA	2398(M)	NA	2426	NA	2454	NA	2482	NA	2510	NA
2371		2399	NA	2427	NA	2455	NA	2483	NA	2511(M)	NA
2372	NA	2400	NA	2428	NA	2456	NA	2484	NA	2512	
2373	NA	2401(A)	NA	2429	NA	2457	NA	2485	NA	2513	C
2374	C	2402(A)	NA	2430	NA	2458	NA	2486	NA	2514	C
2375	NA	2403	NA	2431	NA	2459	NA	2487	NA	2515	NA
2376	NA	2404(A)	NA	2432	NA	2460	NA	2488	NA	2516	NA
2377	NA	2405	NA	2433	NA	2461	NA	2489	NA	2517(M)	NA
2378	NA	2406	NA	2434	NA	2462	NA	2490	NA	2518	NA
2379(M)	A	2407	NA	2435	NA	2463	NA	2491	NA	2519	C
2380(M)	A	2408	NA	2436	NA	2464	NA	2492	NA	2520	C

‡ Incorporated in initial issue of Schedule.
 NA Modification/Amendment not applicable to this Schedule.
 C Modification/Amendment cancelled.
 (A) Amendment.
 (M) Modification

MODIFICATION AND AMENDMENT SHEET
(Airframe)

Mod. No.	A.L. No.	Mod. No.	A.L. No.	Mod. No.	A.L. No.	Mod. No.	A.L. No.	Mod. No.	A.L. No.	Mod. No.	A.L. No.
2521	C	2549	NA	2577	NA	2605	15	2633	15	2661	NA
2522	C	2550	NA	2578	18	2606	NA	2634	15	2662	NA
2523	NA	2551	NA	2579		2607	C	2635		2663	NA
2524	C	2552	NA	2580	NA	2608	C	2636	C	2664	
2525	NA	2553		2581	C	2609	C	2637	C	2665	C
2526	18	2554	C	2582	NA	2610	C	2638	C	2666	C
2527	NA	2555	NA	2583	NA	2611	15	2639	NA	2667	NA
2528	NA	2556	15	2584	20	2612	NA	2640	C	2668	NA
2529	C	2557	NA	2585	22	2613	NA	2641		2669	C
2530	NA	2558	NA	2586	NA	2614	NA	2642	NA	2670	
2531	18	2559	22	2587	NA	2615	NA	2643	15	2671	NA
2532	NA	2560	NA	2588	NA	2616	C	2644	NA	2672	NA
2533	NA	2561	NA	2589	NA	2617	C	2645	NA	2673	NA
2534	NA	2562		2590	NA	2618	NA	2646	NA	2674	NA
2535	15	2563	NA	2591	C	2619	15	2647	NA	2675	C
2536	18	2564	18	2592	NA	2620	NA	2648	NA	2676	NA
2537		2565		2593		2621	NA	2649	NA	2677	
2538	NA	2566	18	2594		2622	NA	2650	NA	2678	NA
2539		2567	NA	2595	NA	2623	NA	2651	NA	2679	C
2540	NA	2568	NA	2596	C	2624	NA	2652	NA	2680	
2541	NA	2569	NA	2597	C	2625	NA	2653	NA	2681	21
2542	NA	2570	NA	2598	NA	2626	NA	2654	NA	2682	NA
2543	NA	2571	17	2599	15	2627		2655	NA	2683	NA
2544		2572	NA	2600	NA	2628	NA	2656	NA	2684	NA
2545		2573	NA	2601		2629	15	2657	NA	2685	NA
2546	NA	2574	C	2602	NA	2630	NA	2658	C	2686	NA
2547	C	2575	NA	2603	NA	2631	C	2659	NA	2687	NA
2548	18	2576	NA	2604	NA	2632	C	2660	NA	2688	NA

‡ Incorporated in initial issue of Schedule.
 NA Modification/Amendment not applicable to this Schedule.
 C Modification/Amendment cancelled.
 (A) Amendment.
 (M) Modification

MODIFICATION AND AMENDMENT SHEET (Airframe)

Mod. No.	A.L. No.	Mod. No.	A.L. No.	Mod. No.	A.L. No.	Mod. No.	A.L. No.	Mod. No.	A.L. No.	Mod. No.	A.L. No.
2689		2717	NA	2745	C	3155	NA	3201	NA	3229	NA
2690	22	2718	NA	2746	C	3156	NA	3202	NA	3230	NA
2691	C	2719	C	2747	C	3157	NA	3203	NA	3231	NA
2692	NA	2720	NA	2748	C	3158	22	3204	NA	3232	NA
2693	NA	2721	NA	2749	C	3159	NA	3205	NA	3233	NA
2694	NA	2722	NA	2750	C	3160		3206	NA	3234	NA
2695	NA	2723	NA	2751		TO	NA	3207	C	3235	NA
2696		2724	NA	TO	NA	3180		3208	C	3236	NA
2697	NA	2725	NA	3135		3181	NA	3209	NA	3237	NA
2698	NA	2726	NA	3136	NA	3182	NA	3210	NA	3238	NA
2699		2727	NA	3137	NA	3183	NA	3211	22	3239	
2700	C	2728	NA	3138	NA	3184	C	3212		3240	NA
2701		2729	NA	3139	NA	3185	NA	3213	NA	3241	NA
2702	20	2730	NA	3140	C	3186	C	3214		3242	NA
2703	15	2731	NA	3141	NA	3187		3215		3243	NA
2704	A	2732	NA	3142	NA	3188	NA	3216		3244	
2705		2733	NA	3143	NA	3189		3217		3245	NA
2706		2734	NA	3144	NA	3190		3218		3246	
2707		2735		3145	NA	3191	C	3219		3247	
2708	NA	2736		3146	NA	3192	NA	3220		3248	NA
2709	NA	2737	NA	3147	NA	3193		3221		3249	NA
2710	NA	2738		3148	NA	3194		3222	NA	3250	NA
2711	NA	2739	20	3149	C	3195		3223	22	3251	
2712	NA	2740		3150	NA	3196	C	3224	NA	3252	NA
2713		2741	C	3151	C	3197	NA	3225		3253	
2714	C	2742	NA	3152	NA	3198	NA	3226	C	3254	NA
2715	C	2743	NA	3153	NA	3199	NA	3227		3255	NA
2716	C	2744	NA	3154	NA	3200	NA	3228	NA	3256	

‡ Incorporated in initial issue of Schedule.
 NA Modification/Amendment not applicable to this Schedule.
 C Modification/Amendment cancelled.
 (A) Amendment.
 (M) Modification.

MODIFICATION AND AMENDMENT SHEET
(Airframe)

Mod. No.	A.L. No.	Mod. No.	A.L. No.	Mod. No.	A.L. No.	Mod. No.	A.L. No.	Mod. No.	A.L. No.	Mod. No.	A.L. No.
3257	C	3285		3326	NA	3367	22	3395	C	3423	
3258	20	3286		3327	NA	3368	22	3396		3424	C
3259	C	3287		3328	NA	3369		3397	NA	3425	NA
3260		3288		3329		3370	NA	3398		3426	NA
3261	NA	3289		3330		3371	NA	3399		3427	NA
3262	C	3290	NA	3331	NA	3372	NA	3400	NA	3428	NA
3263		3291	C	3332	C	3373	C	3401	NA	3429	NA
3264		3292	NA	3333	22	3374	NA	3402	NA	3430	
3265		3293	NA	3334		3375	C	3403	NA	3431	22
3266		3294		TO	NA	3376	C	3404	NA	3432	NA
3267		3295	NA	3349		3377	NA	3405		3433	
3268		3296		3350		3378		3406		3434	
3269		3297	NA	3351	NA	3379	NA	3407		3435	
3270		3298	NA	3352	NA	3380	NA	3408		3436	NA
3271		3299		3353		3381	NA	3409		3437	
3272		3300	NA	3354	NA	3382	NA	3410		3438	NA
3273		3301		3355	NA	3383	20	3411		3439	NA
3274	NA	3302		3356	NA	3384	NA	3412		3440	NA
3275	NA	3303		3357	NA	3385	NA	3413		3441	NA
3276		TO	NA	3358	NA	3386	NA	3414		3442	NA
3277		3318		3359		3387	NA	3415		3443	NA
3278	20	3319	NA	3360		3388	NA	3416		3444	NA
3279	C	3320	NA	3361		3389	NA	3417		3445	NA
3280	NA	3321	NA	3362		3390	NA	3418		3446	NA
3281	22	3322	NA	3363		3391	22	3419		3447	NA
3282	NA	3323	NA	3364		3392	C	3420	NA	3448	NA
3283		3324	NA	3365	C	3393	C	3421	NA	3449	NA
3284		3325	NA	3366		3394	NA	3422	NA	3450	C

‡ Incorporated in initial issue of Schedule.
 NA Modification/Amendment not applicable to this Schedule.
 C Modification/Amendment cancelled.
 (A) Amendment.
 (M) Modification

MODIFICATION AND AMENDMENT SHEET
(Airframe)

Mod. No.	A.L. No.	Mod. No.	A.L. No.	Mod. No.	A.L. No.	Mod. No.	A.L. No.	Mod. No.	A.L. No.	Mod. No.	A.L. No.
3451	C	3479	NA	3507	NA	3535	NA	3563	NA	3591	NA
3452	NA	3480		3508	NA	3536	NA	3564	NA	3592	NA
3453	NA	3481	NA	3509	NA	3537		3565	NA	3593	
3454	NA	3482	NA	3510	NA	3538	NA	3566	NA	3594	NA
3455	NA	3483	NA	3511	C	3539	NA	3567	NA	3595	NA
3456	NA	3484	NA	3512	NA	3540	NA	3568	NA	3596	NA
3457		3485	NA	3513	NA	3541	C	3569	NA	3597	NA
3458	NA	3486	C	3514	NA	3542	C	3570	NA	3598	NA
3459		3487	22	3515	NA	3543	NA	3571	NA	3599	NA
3460	NA	3488	NA	3516	NA	3544	NA	3572	NA	3600	
3461	22	3489	NA	3517	NA	3545	22	3573	NA	3601	
3462	NA	3490	C	3518		3546	NA	3574	NA	TO	NA
3463		3491	NA	3519	NA	3547		3575	NA	3700	
3464		3492	NA	3520		3548		3576	NA	3701	
3465	NA	3493	C	3521		3549		3577	NA	3702	NA
3466	NA	3494		3522	NA	3550		3578		3703	20
3467		3495		3523	NA	3551		3579	NA	3704	NA
3468		3496		3524		3552		3580		3705	NA
3469		3497		3525	NA	3553		3581	NA	3706	23
3470		3498		3526	NA	3554		3582	C	3707	NA
3471		3499		3527	NA	3555	NA	3583	NA	3708	NA
3472		3500		3528	NA	3556	NA	3584	NA	3709	
3473		3501		3529	NA	3557	NA	3585	22	3710	NA
3474		3502		3530	C	3558	NA	3586	NA	3711	NA
3475		3503		3531	C	3559		3587	NA	3712	NA
3476		3504		3532	NA	3560	NA	3588	NA	3713	C
3477	C	3505	NA	3533	NA	3561	NA	3589		3714	NA
3478	NA	3506	NA	3534	NA	3562		3590	NA	3715	

‡ Incorporated in initial issue of Schedule.
 NA Modification/Amendment not applicable to this Schedule.
 C Modification/Amendment cancelled.
 (A) Amendment.
 (M) Modification.

MODIFICATION AND AMENDMENT SHEET
(Airframe)

Mod. No.	A.L. No.	Mod. No.	A.L. No.	Mod. No.	A.L. No.	Mod. No.	A.L. No.	Mod. No.	A.L. No.	Mod. No.	A.L. No.
3716	NA	3744	C	3772						3906	22
3717	NA	3745	22	3773						3911	22
3718	NA	3746	NA	3774	NA					3937	22
3719	NA	3747	NA	3775	C					3962	22
3720	NA	3748		3776							
3721	NA	3749	22	3777							
3722	NA	3750	20	3778							
3723	NA	3751	NA	3779							
3724		3752	NA	3780							
3725		3753	NA	3781							
3726	NA	3754	NA	TO	NA						
3727	NA	3755	NA	3790							
3728	NA	3756	NA	3791							
3729		3757	NA	3792							
3730		3758	NA	3793						4333	23
3731	NA	3759		3794						2183	
3732	NA	3760	C	3795						3225	
3733	NA	3761	NA	3796						3330	
3734	NA	3762		3797						3562	
3735	NA	3763	22	3798	22					3759	
3736	NA	3764	NA	3799	NA					3948	
3737	NA	3765	NA	3800	NA					3749	
3738	NA	3766	C	3801	NA					4003	
3739	NA	3767	NA	3802	C					4048	
3740	NA	3768	NA	3803	C					4076	
3741	NA	3769		3804	C					4077	
3742	NA	3770	NA	3805	NA					4078	
3743	NA	3771	NA	3806						4080	
										4081	
										4095	
										4112	
										4160	
										4229	
										4270	
										4286	
										4307	
										4356	
										4357	

‡ Incorporated in initial issue of Schedule.
 NA Modification/Amendment not applicable to this Schedule.
 C Modification/Amendment cancelled.
 (A) Amendment.
 (M) Modification

This file was downloaded
from the RTFM Library.
Link: www.scottbouch.com/rtfm

Please see site for usage terms,
and more aircraft documents.

