

**EQUIPMENT, ANCILLARY
GROUND EQUIPMENT**

Ref. No.	Part No	Description	No. off	Matl. Spec.	Cl. of Equip.			Plate No.
					M.R.	L.	M.	
	E.A1.88.2	GROUND EQUIPMENT, ASSEMBLY	—	—	—	—	—	
		Spares for:—						
4Q/2627	E.A1.88.77	Adaptor, fuselage jacking	1	—	—	—	B	
1L/178	†	Adaptor, canopy to fuselage torque wrench (Mod. 2536)	1	—	—	—	C	
95087	E.A3.88.157	Arm, nosewheel steering	1	—	—	—	A	
95022	E.A3.88.15	Attachment, nose towing bar	1	—	—	—	A	
4GB/2792	—	Bar, towing	1	—	—	—	A	
	ELECTRO HYDS.							
95103	T.1342/75	Block, split. for air brakes	1	—	—	—	B	
95490	E.A1.88.889	Bolt, canopy slave (ST. 8/4833) (Mod. 2536)	32	S.97	—	—	C	
95413	E.A3.88.307	BRACKET, MAIN WHEEL JACKING, ASSEMBLY (MOD. GE.1451)	2	—	—	—	B	
		Spares for:—						
21870	E.A3.88.219	Bolt, special	2	S.94 or S.95	—	—	C	
95013	E.A3.88.79	Bridge, detachable, for wing slinging	1	—	—	—	A	
1867	E.A1.88.73	Clamp, elevator locking, starboard	1	—	—	—	B	
13142	E.A1.88.873	Clamp, elevator locking, port (Mod. GE2134)	1	—	—	—	B	
1971	E.A3.88.91	Clamp, aileron locking	1	—	—	—	B	
1972	E.A3.88.92	Clamp, aileron locking	1	—	—	—	B	
2468	E.A3.88.153	Clamp, rudder locking, assembly	1	—	—	—	B	
		Spares for:—						
14747	TERRY EX12	Spring	1	—	—	—	C	
	E.A1.88.399	COVERS, AIRCRAFT, ASSEMBLY						
		Spares for:—						
27D/2812	E.A3.88.19	Cover, nose (Pre-Mod. 1027)	1	—	—	—	B	
27D/2948	E.A3.88.301	Cover, nose (Mod. 1027)	1	—	—	—	B	
27D/2809	E.A1.88.401	Cover, coupe	1	—	—	—	B	
27D/2810	E.A1.88.403	Cover, engine	2	—	—	—	B	
27D/2811	E.A1.88.405	Cover, jet pipe	2	—	—	—	B	
27D/2807	E.A1.88.407	Cover, main wheel	2	—	—	—	B	
27D/2806	E.A1.88.409	Cover, nosewheel	2	—	—	—	B	
27D/2666	E.A1.88.597	Cover, pressure head	1	—	—	—	B	
27D/2878	E.A1.88.787	Cover, equipment door	1	—	—	—	B	
95437	E.B7.88.131	Covers, window, photo-cells (Mod. GE.1284)	2	—	—	—	A	
95109	E.A3.88.211	Cradle, for handling jettisonable wing tanks	2	—	—	—	A	
95037	E.A1.88.417	Cradle, restriction test	1	—	—	—	A	
		(For use at Frame 13)						
95038	E.A1.88.419	Cradle, retraction test	1	—	—	—	A	
		(For use at Frame 29)						

**EQUIPMENT, ANCILLARY
GROUND EQUIPMENT**

Ref. No.	Part No	Description	No. off	Mater. Spec.	Cl. of Equip.		Plate No.
					N.R.	L.M.	
		1 2 3 4 5 6					
95072	E.A1.88.551	Dics, setting, engine control, 12 SWG	1	DTD.610	A		GE.2
95047	E.A1.88.359	Extractor, wing to fuselage pick-up pins	1	—	B		GE.2
95044	E.A1.88.375	Extractor, for tab torque tube lever	1	—	B		GE.2
95104	E.A1.88.825	Extractor, for aileron, hinge pin	1	—	B		GE.2
95114	A.6313	Extractor, and assembly tool, wheel	1	—	A		
95462	E.B6.88.103	Extractor, rudder blow back rod (Mod. GE.1912)	1	—	A		
27G/5035	A.10009	Fixture, hydraulic brake alignment	1	—	A		
	E.A1.88.91	FORMERS, ASSEMBLY, DRAWINGS, PORT	—	—	—		
95025	E.A1.88.91A	Former, wing lifting gantry, forward, port	1	—	B		GE.2
95026	E.A1.88.91B	Former, wing lifting gantry, centre, port	1	—	B		GE.2
95027	E.A1.88.91C	Former, wing lifting gantry, aft, port	1	—	B		GE.2
95028	E.A1.88.91D	Former, wing lifting gantry, forward, port	1	—	B		GE.2
95029	E.A1.88.91E	Former, wing lifting gantry, centre, port	1	—	B		GE.2
95030	E.A1.88.91F	Former, wing lifting gantry, aft, port	1	—	B		GE.2
	E.A1.88.92	FORMERS, ASSEMBLY, DRAWINGS, STARBOARD	—	—	—		
95031	E.A1.88.92A	Former, wing lifting gantry, forward, starboard	1	—	B		GE.2
95032	E.A1.88.92B	Former, wing lifting gantry, centre, starboard	1	—	B		GE.2
95033	E.A1.88.92C	Former, wing lifting gantry, aft, starboard	1	—	B		GE.2
95034	E.A1.88.92D	Former, wing lifting gantry, forward, starboard	1	—	B		GE.2
95035	E.A1.88.92E	Former, wing lifting gantry, centre, starboard	1	—	B		GE.2
95036	E.A1.88.92F	Former, wing lifting gantry, aft, starboard	1	—	B		GE.2
95115	E.A3.88.179	Gauge, tailplane, incidence and dihedral	1	—	A		
95010	E.A1.88.93	Gauge, wing incidence dihedral	1	—	A		
95040	E.A1.88.447	Gauge, levelling, cockpit lateral and fuselage longeron	1	—	A		
95093	E.A1.88.747	Gauge, levelling, cockpit longeron and fuselage lateral	1	—	A		
95532	E.A1.88.893	Gauge, inspection, assembly of canopy to fuselage (Mod. 2536)	1	—	B		

**EQUIPMENT, ANCILLARY
GROUND EQUIPMENT**

Ref. No.	Part No.	Description	No. off	Matl. Spec.	Cl. of Equip.	Plate No.
					M.R. L.M.	
		1 2 3 4 5 6				
95100	E.A1.88.823	Gauge, aileron, fixed tab angle checking	1	—	A	
95273	E.A1.88.785	GEAR, LIFTING, COMPLETE AIRCRAFT, ASSEMBLY (MOD. GE.876) Spares for:—	1	—	A	
95526	E.A3.88.317	Bolt, special, shouldered	2	S.97	C	
95527	E.A3.88.319	Washer, special	2	Comm. M.S.	C	
95099	E.A1.88.817	GUARD, AIR INTAKE DEBRIS, ASSEMBLY	2	—	A	
		Spares for:—				
95503	E.A3.88.295	Bolt, key	2	Comm. M.S.	C	
1B/4467	—	Gun, lubricating	1	—	A	
4Q/2626	E.A1.88.257	Head, 10-ton, jack adaptor	2	Comm. M.S.	B	
	E.B7.88.199	HOIST, MINILIFT, 250 lbs. GREEN SATIN INSTALLA- TION, GROUP (MOD. GE.1261) Consisting of:—	1	—	—	
4GC/5433	25/41	End; ball	1	—	C	
4GC/5430	39/2	Handle, winding, w/slipping clutch, 6"	1	—	B	
4GC/5425	26/63	Hoist, winding, 250 lbs., 20 ft. lift	1	—	B	
4GC/5432	30/14	Sheath, top	1	—	A	
4GC/5431	29/13	Tube, extension, 4½"	1	—	B	
95293	E.A1.88.831	Indicator, engine controls setting disc	1	—	A	
95051	E.A1.88.349	Insertor, piston ring main undercarriage oleo leg	1	DTD.610	A	
95048	E.A1.88.363	Insertor, wing to fuselage pick-up pins	1	—	A	
95052	E.A1.88.383	Insertor, main oleo pivot point bush	1	—	A	
95050	E.A1.88.389	Insertor, for bushes in torque links, main oleo leg	1	—	A	
95053	E.A1.88.391	Insertor, and extractor, for sealing rings, main oleo leg	1	—	A	
95088	E.A1.88.733	Insertor, main undercarriage pivot pin	1	—	A	
4Q/2232	—	Jack, hydraulic, fuselage	1	—	A	
95647	FT8/2571	Jig, alignment, vent mast (Mod. 4112)	1	—	B	
95063	E.A1.88.395	Key, hydraulic, tank	1	—	B	
1970	E.A1.40.169	Lug, picketing and towing	2	S.11	C	
27Q/11743	D.2606Y	Nozzle, flexible, c/w gauge	1	—	A	
95015	E.A1.88.255	Pin, nosewheel locking	1	—	B	
95491	E.A1.88.891	Pin, locating (ST.8/4842) (Mod. 2536)	6	—	C	
95294	E.A1.88.547	Plate, setting, bell crank lever, engine control, port	1	—	B	
95295	E.A1.88.548	Plate, setting, bell crank lever, engine control, star- board	1	—	B	
95074	E.A1.88.549	Plate, setting, throttle box, 16 SWG	1	DTD.610	B	

**GROUND EQUIPMENT
EQUIPMENT, ANCILLARY**

Ref. No	Part No.	Description	No. off	Matl. Spec.	Cl. of Equip.		Plate No.
					M.R.	L.M.	
		1 2 3 4 5 6					
95270	E.A3.88.281	PLUG, BLANKING, CABIN PRESSURE CONTROL, VALVE, GROUP Consisting of:—	1	—		B	
	†	Chain, retaining	QR	Brass		—	
21084	E.A2.88.77	Pennant	1	—		C	
	E.A3.88.283	Plug:	1	L.40		—	
	—	Ring, split: 1/2" o/d x 1/16"	2	—		C	
6A/2679	—	Plugs, protective, static vent	4	—		B	
1C/2161	—	Screwdriver	1	—		B	
95071	E.A1.88.599	Seal, engine dust	2	—		A	
95091	E.A1.88.797	SLAVE, COWLING, PORT, ASSEMBLY	1	—		A	
		Spares for:—					
10699	E.A1.50.1055	Cover, plate, debris guard attachment plate	2	DTD.610		C	
95458	E.A1.88.809	PIPE, EXHAUST, ASSEMBLY	2	—		C	
		Spares for:—					
21694	E.A1.88.813	Screw, special	3	S.1		C	
21695	E.A1.88.849	Screw, special	2	S.1		C	
21696	E.A1.88.851	Screw, special	4	S.1		C	
95092	E.A1.88.728	SLAVE, COWLING, STARBOARD, ASSEMBLY	1	—		A	
		Spares for this assembly are identical with those for Port assembly Pt. No. E.A1.88.797					
95089	E.A1.88.743	SLEEVE, MAIN UNDERCARRIAGE WHEEL LOCKING, GROUP	2	—		A	
		Spares for:—					
21084	E.A2.88.77	Pennant:	2	—		C	
	AVIATN.DEVELS.						
28FP/9432064	A.817	Pin, "pip," quick release	2	—		C	
95008	E.A1.88.11	Sling and frame, main plane lifting, complete	1	—		A	
95009	E.A1.88.59	Sling, tailplane	1	—		A	
95039	E.A2.88.1	Sling, front and centre fuselage lifting, complete	1	—		A	
95007	E.A1.88.65	Sling, rear fuselage lifting, complete	1	—		A	
95498	E.A2.88.5005	Sling, spreader, cameras (Mod. GE.2526)	1	—		A	
95434	E.B7.88.135	Sling, front and rear assembly, tracking unit, green satin (Mod. GE.1261)	1	—		A	

**EQUIPMENT, ANCILLARY
GROUND EQUIPMENT**

Ref. No.	Part No.	Description	No. off	Matl. Spec.	Cl. of Equip.		Plate No.
					M.R.	L.M.	
		1 2 3 4 5 6					
95433	E.B7.88.143	Sling, rear assembly, T/R green satin (Mod. GE.1261)	1	—		A	
95432	E.B7.88.183	Sling, front assembly, T/R green satin (Mod. GE.1261)	1	—		A	
95084	E.A1.88.601	Sling, fin and rudder	1	—		A	
1L/45	—	Socket, for attachment bolts, ¼" BSF	2	—		A	
1L/67	—	Socket, for attachment bolts, 1" BSF	6	—		A	
1L/22	—	Socket, ⅞" BSF, for explosive bolts	1	—		A	
95268	E.A2.88.113	Spanner, special box, for ventral tank filler pipe ...	1	—		B	
95064	E.A1.88.263	Spanner, integral and drop tanks, drain plug	1	DTD.124A		B	
95269	E.A3.88.293	Spanner, wing tip tank, drain plug	1	—		B	
95493	E.A1.88.877	Spanner, nosewheel "up" locks release (Mod. 2311) ...	1	—		B	
95054	E.A1.88.345	Spanner, torque link, main undercarriage, special screw	1	DTD.124		B	
95056	E.A1.88.347	Spanner, special C, main undercarriage oleo stop nut	1	—		B	
95057	E.A1.88.353	Spanner, special, main undercarriage oleo piston ...	1	—		B	
95325	E.A3.88.303	Spanner, special, main undercarriage oleo bearing ring	1	Steel		B	
95086	E.A3.88.135	Spanner, special, main undercarriage oleo axle clamp	1	Steel		B	
95065	E.A1.88.365	Spanner, special, plug forward jacking point housing	1	—		B	
95046	E.A1.88.379	Spanner, universal, for attaching aileron to centre hinge bracket	1	M.S.		B	
95059	E.A1.88.385	Spanner, special, for undercarriage pivot pin	1	M.S.		B	
95060	E.A1.88.387	Spanner, special, for undercarriage pivot nut	1	M.S.		B	
95079	E.A1.88.531	Spanner, special, for drop tank, assembly	1	M.S.		B	
1L/3226	—	Spanner, union, main fuel feed	2	—		B	
95004	E.A1.88.23	Spigot, forward jacking, front fuselage	1	S.65		B	
95436	E.B7.88.129	Strap, for camera sling (Mod. GE.1284)	2	Nylon rope		B	
95090	E.A1.88.799	Strut, jury, tailplane	1	—		A	

**EQUIPMENT, ANCILLARY
GROUND EQUIPMENT**

Ref. No.	Part No	Description	No. off	Matl. Spec.	Cl. of Equip.	Plate No.
					M.R. L.M.	
		1 2 3 4 5 6				
	E.A3.88.221	TEMPLATES, NEUTRAL RIGGING, ASSEMBLY	—	—	—	
		Spares for:—				
95266	E.A3.88.257	Template, neutral rigging, aileron	1	—	A	
95267	E.A3.88.223	Template, neutral rigging, elevator	1	—	A	
95265	E.A3.88.247	Template, neutral rigging, rudder	1	—	A	
95096	E.A2.88.71	TIE, FLARE DOOR JURY, GROUP	2	—	B	
		Spares for:—				
21084	E.A2.88.77	Pennant	1	—	C	
28FF/4	AVIATN. DEV. LTD. A.407	Pin, "pip"	2	—	C	
29H/4099	TERRY LTD. No. 169-3/4"	Ring, split	8	—	C	
95061	E.A1.88.351	Tool, shock absorbing, piston centralising	1	—	A	
95062	E.A1.88.361	Tool, special combination, main undercarriage oleo insertion and extraction of spherical bearing	1	—	A	
95101	E.A1.88.821	Tool, setting, for aileron fixed tab	1	—	B	
95082	MARTIN BAKER A/MBEU/70/EE	Tool, for cocking and uncocking snatch unit	1	—	A	
	E.A1.88.87	TRESTLES, REAR FUSELAGE, ASSEMBLY	—	—	—	
		Spares for:—				
95017	E.A1.88.87A	Former, forward	1	Spruce	B	
95018	E.A1.88.87B	Former, aft	1	Spruce	B	
95083	E.A2.88.35	TROLLEY, VENTRAL TANK	1	—	A	
		Spares for:—				
95487	E.A2.88.53	Wheel, trolley (Capowheel T.82)	4	—	B	
95431	E.B7.88.149	Trolley, front and rear assembly, green satin installation (Mod. GE.1261)	1	—	A	
1C/6239	—	Wrench, torque, for attachment bolts	1	—	A	
1C/6447	—	Wrench, torque, pilot's canopy	1	—	A	
1L/156	JENKS BROS. LTD. E.V.T.360	Wrench, torque, for explosive bolts, canopy to fuselage attachment (Mod. 2536)	1	—	C	

GROUND EQUIPMENT

Ref. No.	Part No.	Description					No. off	Matl. Spec.	Cl. of St.	Plate No.
		1	2	3	4	5			M.R. L.M.	
	—	TRANSPORTATION EQUIPMENT					—	—	—	
95279	—	Beam, transportation, fuselage, nose (43G/SAL/180)					1	Deal	B	
95280	—	Beam, transportation, mid-section front fuselage (43G/SAL/180)					1	Deal	B	
95281	—	Beam, transportation, fuselage rear section rear (43G/SAL/181)					1	Deal	B	
95282	—	Beam, transportation, fuselage rear section front (43G/SAL/181)					1	Deal	B	
95285	—	Beam, transportation, fuselage mid-section rear (43G/SAL/182)					1	Ash	B	
95289	—	Beam, transportation, main plane, outer, port (43G/SAL/194)					1	Ash	B	
95290	—	Beam, transportation, main plane, outer, starboard (43G/SAL/194)					1	Ash	B	
95291	—	Beam, transportation, (support blocks) main plane (43G/SAL/195)					2	R.S.J.	B	
95286	—	Block, transportation, main plane, front (43G/SAL/185)					2	Ash	B	
95287	—	Block, transportation, main plane, rear (43G/SAL/185)					2	Ash	B	
95288	—	Block, transportation, main plane, centre (43G/SAL/185)					2	Ash	B	
95283	—	Pedestal, transportation, tailplane (43G/SAL/183)					1	M.S.	B	
95284	—	Pedestal, transportation tailplane (43G/SAL/184)					2	M.S.	B	
<p>NOTE : The number off shown is the quantity required for the transportation of one aircraft.</p>										



Pages 357 to 368 not issued



**EQUIPMENT, ANCILLARY
GROUND EQUIPMENT**

Ref. No.	Part No.	Description 1 2 3 4 5 6	No. off	Matl. Spec.	Cl. of Equip.	Plate No.
					M.R. L.M.	
SUMMARY OF STOCK ITEMS USED ON GROUND EQUIPMENT, ASSEMBLY						
28D/12531	A25/3C	Bolt, 2 BA, hex. head, "75 long	C	
28D/1200129	A25/4C	Bolt, 2 BA, hex. head, "85 long	C	
28D/12556	AS.1246/12½C	Bolt, 2 BA, round head, "65 long	C	
28D/8347	AS.1248/10C	Bolt, 2 BA, mushroom head, 1"4 long	C	
28D/12901	AS.1248/28B	Bolt, 4 BA, mushroom head, 3"15 long	C	
28M/13124	A27/CT	Nut, 2 BA, thin	C	
28M/12931	A27/ET	Nut, ¼" BSF, thin	C	
28M/10327	AGS.2002/B/1	Nut, stiff, 4 BA	C	
28P/12464	SP.9/G10	Pin, split, ¼" dia. x 1¼" long	C	
28P/12647	SP.9/G8	Pin, split, ¼" dia. x 1" long	C	
28S/2864	A32/A16	Screw, 6 BA, round head, ½" long	C	
28W/9419466	SP13/J	Washer, ¾" BSF, plain	C	
28W/9419468	SP13/N	Washer, ½" BSF, plain	C	
28W/9419475	SP15/C	Washer, 2 BA, plain	C	

Restricted

Ref No.	Part No.	1 2 3 4 5 6	Description	No. off	Mati. Spcc.	Cl. of Equip.	Plate No.
						M.P. L.M.	

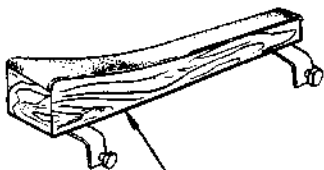
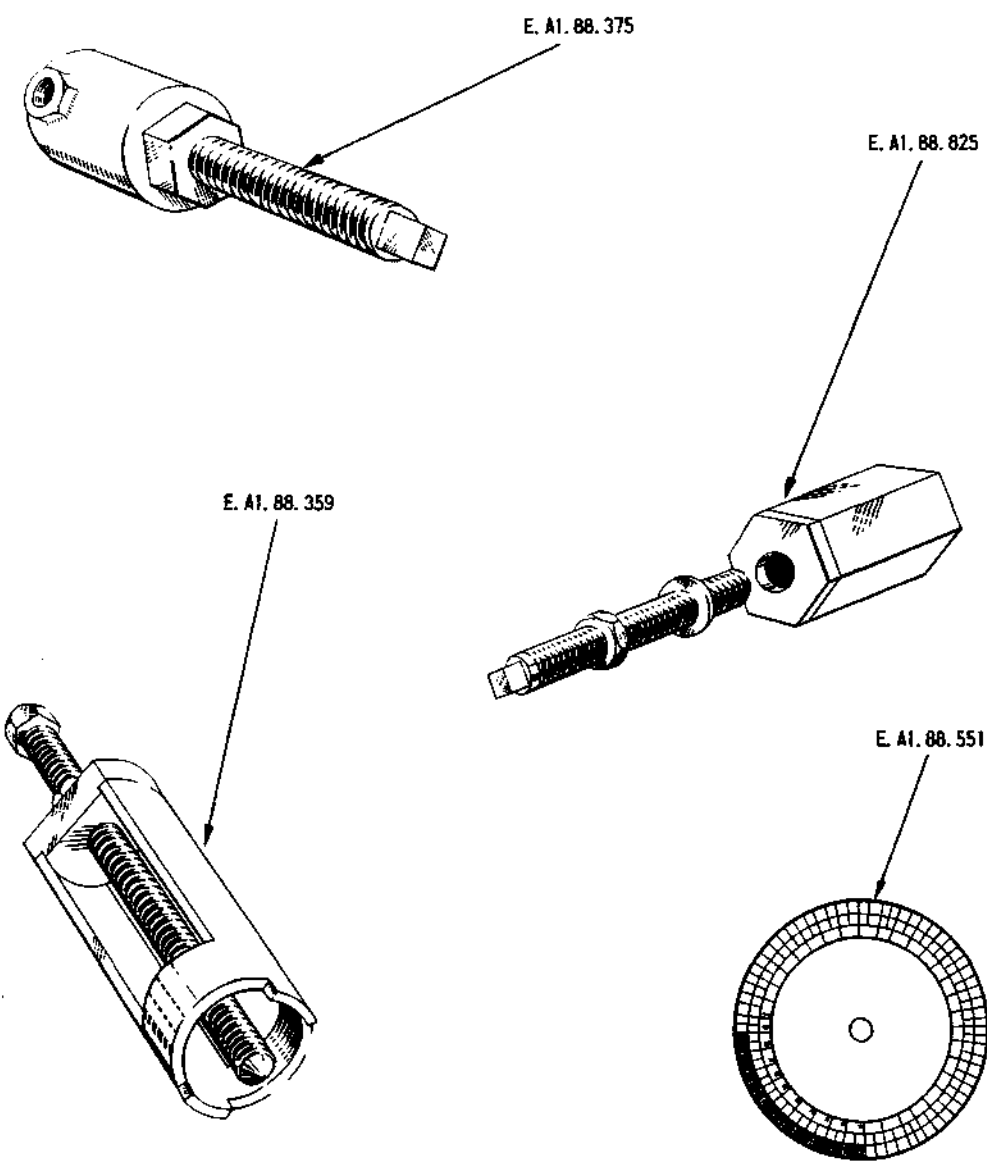

INBOARD { E. A1. 88. 91A
E. A1. 88. 92A
OUTBOARD { E. A1. 88. 91D
E. A1. 88. 92D

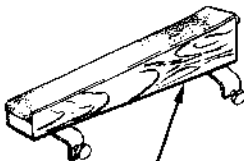

INBOARD { E. A1. 88. 91B
E. A1. 88. 92B
OUTBOARD { E. A1. 88. 91E
E. A1. 88. 92E

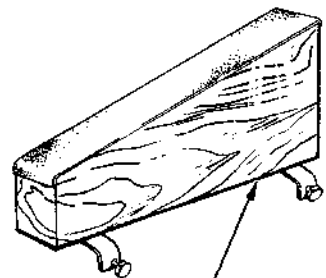

INBOARD { E. A1. 88. 91C
E. A1. 88. 92C
OUTBOARD { E. A1. 88. 91F
E. A1. 88. 92F



This file was downloaded
from the RTFM Library.
Link:www.scottbouch.com/rtfm

Please see site for usage terms,
and more aircraft documents.

