

**TANKS**  
**JETTISON WING FUEL TANK, PORT**

Ref. No.	Part No.	Description	No. off	Matl. Spec.	Cl. of Equip.	Plate No.
					M.R. L.M.	
12867	E.A3.00.505	<b>JETTISON WING FUEL TANK INSTALLATION, 250 GALLONS (LESS DETONATORS) WITHOUT VORTEX GENERATORS (PRE-MOD. 2395)</b> Consisting of:—	1	—	A	
	E.A1.00.81	<b>ATTACHMENT DETAILS, DROP TANK TO WING</b> Consisting of:—	—	—	—	
1577	E.A1.20.2031	<b>Bolt, explosive</b> ... ..	3	DTD.683	C	JT.1
	E.A1.81.317	<b>DETONATOR, FORWARD, EXPLOSIVE BOLT, GROUP</b> Consisting of:—	1	—	—	
12G/1279	E.A3.81.353	<b>Detonator</b> ... ..	1	—	C	JT.1
1578	E.A1.81.939	<b>Plug</b> ... ..	1	—	C	JT.1
5K/9107065	†	<b>Sleeve, 1" x 1/4"</b> ... ..	2	—	C	JT.1
5K/9107067	†	<b>Sleeve, 3" x 1/2"</b> ... ..	1	—	C	JT.1
1579	E.A1.81.938	<b>Spring</b> ... ..	1	—	C	JT.1
5X/9400061	Z.19924	<b>Tag, terminal, quick release</b> ... ..	2	—	C	JT.1
5X/9400062	Z.19979	<b>Thimble, quick release</b> ... ..	2	—	C	JT.1
1580	E.A1.81.428	<b>Tube, detonator</b> ... ..	1	—	C	JT.1
5F/2124	†	<b>Tube, rubber, No. 2, Hellermann</b> ... ..	QR	—	C	
	E.A1.81.318	<b>DETONATOR, REAR OUTBOARD EXPLOSIVE BOLT, GROUP</b> Spares for this group are identical with those for group Part No. E.A1.81.317	1	—	—	
	E.A1.81.599	<b>DETONATOR, REAR, INBOARD EXPLOSIVE BOLT, GROUP</b> Spares for this group are identical with those for group Part No. E.A1.81.317	1	—	—	
28M/10335	AGS.2002/Q1	<b>Nut, stiff, 3/8" BSF, thin</b> ... ..	3	—	C	JT.1
2134	E.A1.57.1239	<b>Pipe, air break, c/w stop</b> ... ..	1	—	C	JT.1
2135	E.A1.57.1241	<b>Pipe, fuel break, c/w stop</b> ... ..	1	—	C	JT.1
1584	E.A1.20.8833	<b>Washer, special explosive bolt</b> ... ..	3	DTD.683	C	JT.1
	E.A3.62.175 or BRISTOL A/C 75.04.0001	<b>TANK, DROP (LESS ATTACHMENTS), GROUP</b> ... .. Spares for:—	1	— Durestos Plastic	—	
5CZ/4300	E.A3.62.113	<b>Block, contact, navigation light</b> ... ..	1	—	B	JT.1
20505	E.A3.62.151	<b>Body, filler cap</b> ... ..	1	—	C	
12940	E.A3.62.191	<b>CAP, FILLER, C/W INWARD VENT VALVE, ASSEMBLY (MOD. 1932)</b> Spares for:—	1	—	B	
5249	E.A2.62.143	<b>Washer, sealing, filler cap, assembly</b> ... ..	1	—	C	
13158	E.A3.62.197	<b>Washer, sealing, vent valve head</b> ... ..	1	Hycatrol 257	C	

**TANKS**  
**JETTISON WING FUEL TANK, PORT**

Ref. No	Part No.	Description	No. off	Matl. Spec.	Cl. of Equip.		Plate No.
					M.R.	L.M.	
		1 2 3 4 5 6					
	E.A2.62.73	<b>FUEL PIPE AND MOUNTING, ASSEMBLY</b> ...	—	—	—		
		Spares for:—					
2136	E.A2.62.227	Clip, hose ...	1	—	C		JT.1
2137	E.A2.62.229	Clip, hose ...	1	—	C		JT.1
28E/9429463	AGS.605/O	Clip, hose ...	2	—	C		JT.1
28E/9129092	AG6.605/2	Clip, hose ...	2	—	C		JT.1
	EEAS.77/84	Hose, fuel break pipe, 1½" i/d x 1⅝" o/d x 2½" long, type 1 (Make from 32C/455)	1	DTD.625	LM		
	EEAS.77/32	Hose, air break pipe, ½" i/d x ¼" o/d x 2¼" long, type 1 (Make from 32C/449)	1	DTD.625	LM		
3392	E.A3.62.77	Panel, access, top skin ...	1	—	C		JT.1
12922	E.A3.62.189	<b>SOCKET, EARTHING, GROUP</b> ...	1	—	C		
		Consisting of:—					
	E.A3.62.181	Cap, sealing ...	1	DTD.683	—		
	E.A3.62.177	Socket, earth plug ...	1	DTD.683	—		
	E.A3.62.183	Spring ...	1	DTD.215	—		
	E.A3.62.115	Strip, sealing, 6ft. long (Make from Ref. 4432) ...	1	Synthetic Rubber	LM		
5511	E.A1.20.10897	<b>VALVE, DRAIN, GROUP</b> ...	1	—	B		JT.1
		Spares for:—					
	E.A1.20.10901	<b>PLUG, DRAIN, GROUP</b> ...	1	—	—		
		Spares for:—					
	E.A1.20.10903	Plug, housing ...	1	L.40	—		
5512	E.A1.20.10907	Plug, ½" BSP ...	1	L.40	C		JT1
12335	E.A1.20.10905	Ring, hycatrol ...	1	Grade HE.4	C		
12904	E.A3.62.117	Washer, special, ⅜" ...	50	Petrolite	C		
12923	E.A3.62.185	Washer, sealing earthing socket ...	1	Neo-K-Tex	C		
3458	E.A1.20.2903	Washer, sealing ...	4	Neo-K-Tex	C		
14717	E.B6.00.347	<b>JETTISONABLE WING FUEL TANK INSTALLATION, 250 GALLON, WITH VORTEX GENERATORS (LESS DETONATORS), PORT (MOD. 2395)</b>	1	—	A		
		Spares for this group are identical with those for group Part No. E.A3.00.505 on page 447, except for the following deletion and addition					
		Delete:—					
	E.A3.62.175 or BRISTOL A/C	<b>TANK, DROP (LESS ATTACHMENTS), GROUP</b> ...	1	—	—		
14683	75.04.0001		—	Durestos Plastic	—		
		Add:—					
	E.A3.62.217 or BRISTOL A/C	<b>TANK, DROP (LESS ATTACHMENTS), GROUP</b> ...	1	—	—		
14683	75.04.0001		—	Durestos Plastic	—		

**TANKS**  
**JETTISON WING FUEL TANK, STARBOARD**

Ref. No	Part No.	Description	No. off	Matl. Spec	Cl. of Equip.	Plate No.
					M.R. L.M.	
12868	E.A3.00.506	<b>JETTISON WING FUEL TANK INSTALLATION, 250 GALLONS, WITHOUT VORTEX GENERATORS (LESS DETONATORS) STARBOARD (PRE-MOD. 2395)</b> Consisting of:—	1	—	A	
	E.A1.00.82	<b>ATTACHMENT DETAILS, DROP TANK TO WING</b> Spares for this group are identical with those for group Part No. E.A1.00.81 on page 447	—	—	—	
	E.A3.62.176 or BRISTOL A/C	<b>TANK, DROP (LESS ATTACHMENTS) GROUP ...</b> Spares for this group are identical with those for port group Part No. E.A3.62.175 on page 448 except for the following deletion and addition Delete:—	1	—	—	
14684	75.04.0002		—	Durestos Plastic	A	
	E.A2.62.73	<b>FUEL PIPE AND MOUNTING ASSEMBLY ...</b> Add:—	—	—	—	
	E.A2.62.74	<b>FUEL PIPE AND MOUNTING ASSEMBLY ...</b> Spares for this assembly are identical with those for Part No. E.A2.62.73 on page 448	—	—	—	
14718	E.B6.00.348	<b>JETTISON WING FUEL TANK INSTALLATION, 250 GALLONS WITH VORTEX GENERATORS (LESS DETONATORS) STARBOARD (MOD. 2395)</b> Spares for this group are identical with those for group Part No. E.A3.00.506 except for the following deletion and addition Delete:—	1	—	A	
	E.A3.62.176 or BRISTOL A/C	<b>TANK, DROP (LESS ATTACHMENTS), GROUP ...</b>	1	—	—	
14684	75.04.0002		—	Durestos Plastic	A	
	E.A3.62.218 or BRISTOL A/C	<b>TANK, DROP (LESS ATTACHMENTS), GROUP ...</b>	1	—	—	
14684	75.04.0002		—	Durestos Plastic	A	

Ref. No.	Part No.	1	2	3	4	5	6	Description	No. off	Matl. Spec.	Cl. of Equip.	Plate No.
											M.R.	

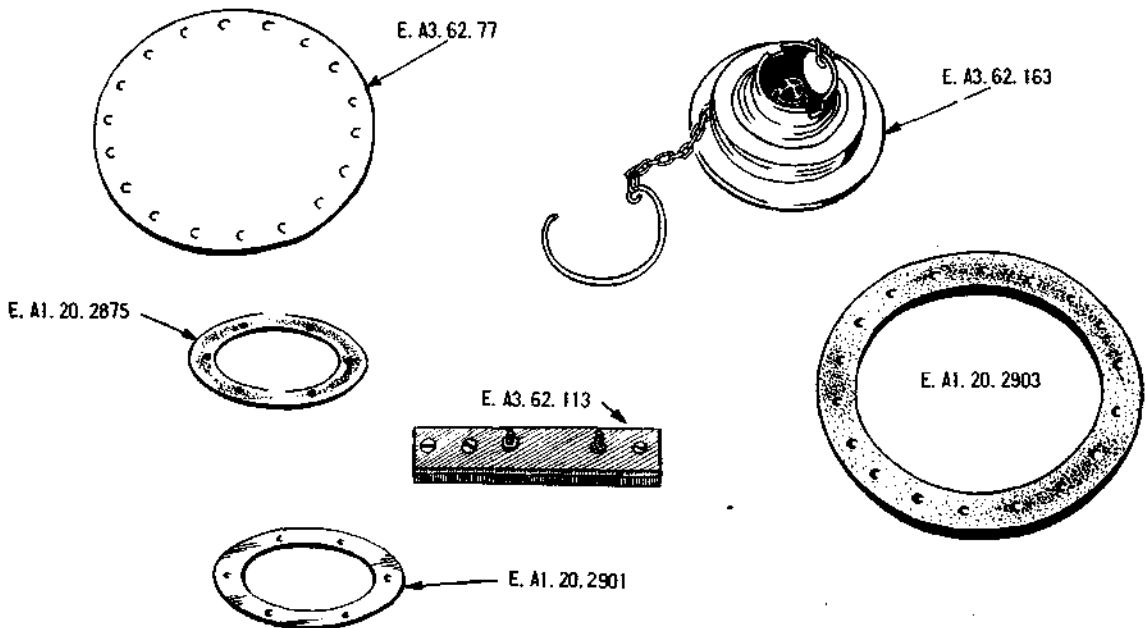
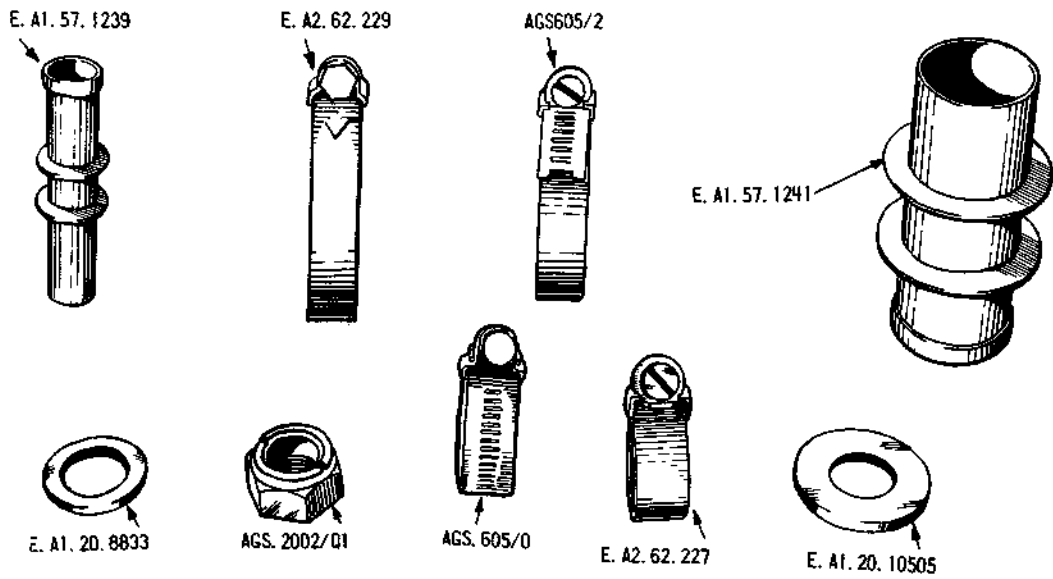
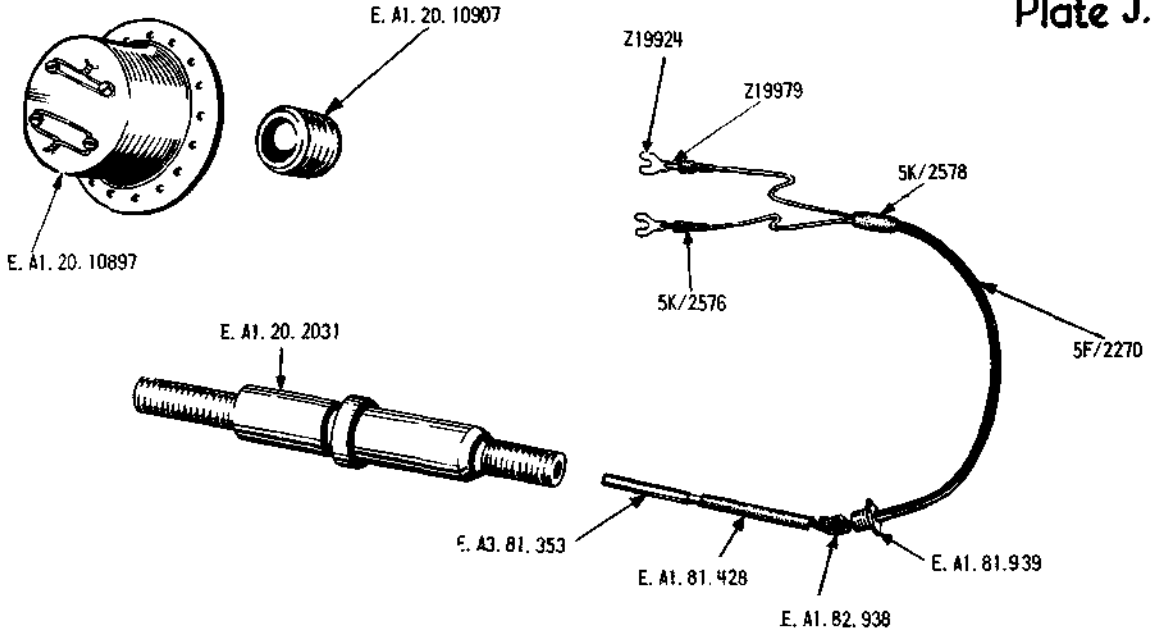



This file was downloaded from the RTFM Library.

Link: [www.scottbouch.com/rtfm](http://www.scottbouch.com/rtfm)

Please see site for usage terms, and more aircraft documents.

