

PART I

DESCRIPTIVE

NOTE.—Throughout this publication the following conventions apply:—

- (a) Words in capital letters indicate the actual markings on the controls concerned.
- (b) The numbers quoted in brackets after items in the text refer to the illustrations in Part VI.
- (c) Unless otherwise stated all airspeeds and Mach numbers quoted are "Indicated".
- (d) Fuel states quoted in pounds are, unless otherwise stated, at a density of 8 lb. per gallon (normal AVTUR).

1. Introduction

- (a) The Canberra B.6 is a light bomber powered by two Avon Mk. 109 engines, each of 7,400 lb. static thrust at sea level. The cabin is pressurised and provides accommodation for a crew of three seated in ejection seats. There is an alternative position in the nose for the bomb-aimer, but no provision is made for his ejection from this station. Immediately aft of the cabin rear pressure bulkhead are four bays, upper, lower, port and starboard, containing various items of aircraft equipment. Bombs are carried in a bay in the belly of the fuselage, and provision is made for carrying an F.24 camera in the rear fuselage aft of the bomb bay. A variable incidence tailplane is fitted.
- (b) The B.(I)6 is a B.6 modified for conversion to an interdicator role. Special doors are fitted to the bomb bay which accommodates a gun pack at the rear; flares may be carried in the front of the bay. A Mk. 3N reflector gun sight is above the pilot's instrument panel. Pylon mountings for carrying bombs or rocket batteries are fitted below the wings outboard of the engines. An F.24 camera may be carried in the rear fuselage aft of the bomb bay, and a G.45 gun camera in the starboard wing leading edge. The control column hand wheel is modified and carries gun, bomb and camera controls on its right grip.

PART I—DESCRIPTIVE

- (c) The location of the pilot's flying controls is conventional: other controls and instruments are grouped as follows:—
 - (i) To the left of the pilot on the cockpit port wall and on the port console (figs. 2 and 3); forward of the port console on the engine controls quadrant and above this quadrant, on the port front panel.
 - (ii) In front of the pilot on the instrument panel (fig. 4) and on the coaming above this panel. The instrument panel is divided into three sections; from left to right, the main instrument panel, the engine instrument panel and the miscellaneous instrument panel. Beneath the main instrument panel is the engine starter panel.
 - (iii) To the right of the pilot on the cockpit starboard wall (fig. 5).
 - (iv) To the right and aft of the pilot on the electrical control panel (fig. 1).

The location of all controls and instruments is given relevant to the above positions.

FUEL AND OIL SYSTEMS

2. Fuel tanks

(a) *Fuselage tanks*

Three fuel tanks, of flexible construction, are fitted in the fuselage above the bomb bay. Numbered, 1, 2 and 3 from front to rear, No. 1 and 2 tanks are self sealing while No. 3 tank is a crash proof collapsible fuel bag. The tanks are vented to atmosphere through a common pipe terminating at an outlet aft of No. 3 tank on the fuselage starboard upper surface. Mod. 1728 moves the vent outlet further aft, to terminate on the fuselage under the starboard tailplane. Flush fitting filler caps, one for each tank, are on the port upper surface of the fuselage.

(b) *Wing integral tanks*

An integral tank, divided into interconnected outboard and inboard compartments, is in each wing leading edge, outboard of the engine. Each compartment has an electrically heated vent valve and a flush fitting filler cap on its upper surface.

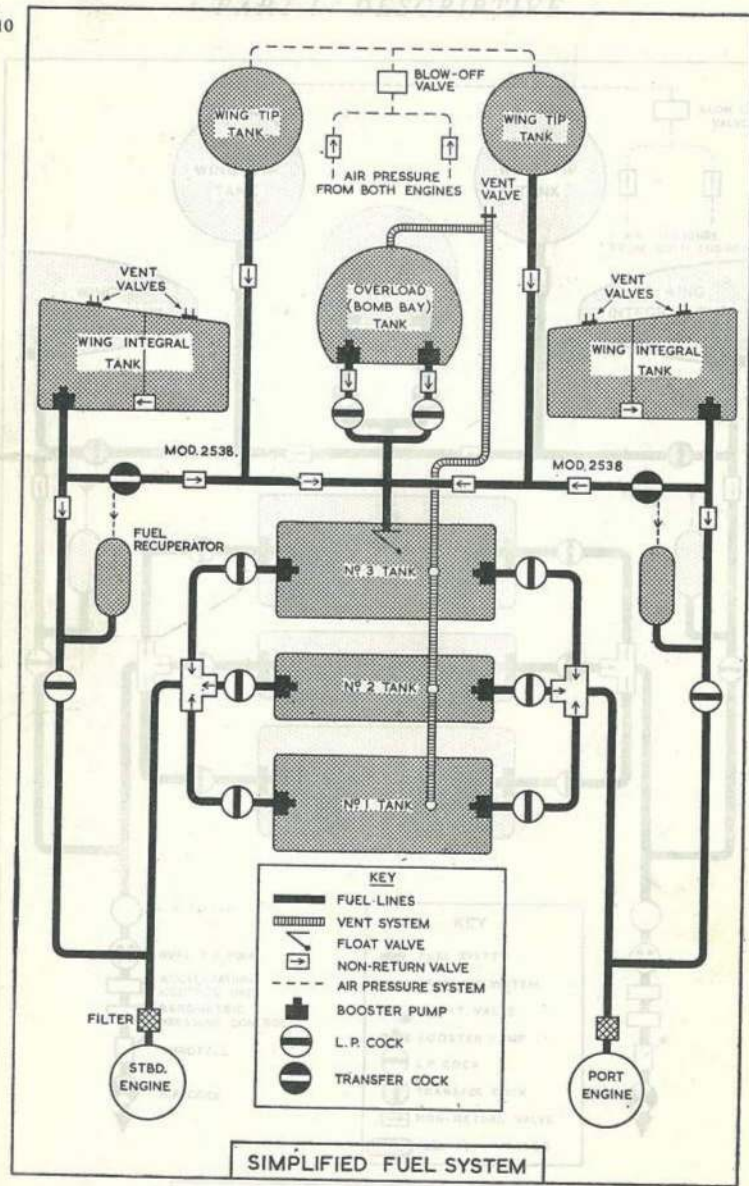
(c) *Wing tip tanks*

- (i) Jettisonable wing tip tanks may be fitted. No cocks or controls, except the jettison pushbutton (see below) are provided as these tanks feed automatically and together under air pressure from the engine compressors through a float valve in No. 3 tank. A flush fitting filler cap is on the front outboard upper surface of each tank.
- (ii) The wing tip tanks may be jettisoned, full or empty, by pressing the FUEL TANK JETTISON pushbutton (25) on the port front panel; this jettisons both tanks simultaneously by firing electrically the explosive retaining bolts.

(d) *Overload tank*

Provision is made for fitting an overload tank, of 300 gallons capacity, in the bomb bay. On the B.(I)6 this tank can only be carried when the gun pack is not fitted. From this tank fuel is fed to No. 3 tank by two booster pumps through two cocks. Although this fuel is fed in through a float valve, owing to the booster pump pressure the float valve should not be relied on to prevent flooding. The switches (when fitted) for the interconnected booster pumps and cocks are on the miscellaneous instrument panel. When the switches are put ON the pumps start running and the cocks open.

3. **Fuel recuperators**

- (a) With Mod. 1954 embodied fuel recuperators, one for each engine, are provided to compensate for negative G conditions.
- (b) Each recuperator comprises a flexible bag contained within a casing, the bag being connected to the fuel delivery line between the integral tank and the engine. Air is fed from the engine compressor to the casing so that it acts on the flexible bag at a constant pressure. The pressure from the booster pumps is greater than this air pressure so that the bag is charged with fuel. If the booster pumps cease to deliver fuel due to negative G conditions or for any other reason, the air pressure will collapse the bag and discharge its contents to the engine. The recuperator will recharge as soon as the booster pumps again start to deliver fuel. Referring to the simplified fuel system diagram will show

PART I—DESCRIPTIVE

that the integral L.P. cocks must be open for the recuperators to be effective and consequently the transfer cock must be shut (NORMAL) (see para. 5 (a)).

- (c) The supply of fuel in each bag will feed an engine for about 10 seconds at full power at sea level.

4. Fuel tank capacities and contents gauges

- (a) The effective fuel capacities are approximately:—

| | | | <i>lb. at 7.7 lb./ gall.</i> | <i>lb. at 8.0 lb./ gall.</i> |
|---|-------|-------|--------------------------------------|--------------------------------------|
| No. 1 tank | | 520 | 4,004 | 4,160 |
| No. 2 tank | | 317 | 2,441 | 2,536 |
| No. 3 tank | | 540 | 4,158 | 4,320 |
| Integral wing tanks (2 @ 450 gallons) | | 900 | 6,930 | 7,200 |
| <i>Total internal fuel</i> | | 2,277 | 17,533 | 18,216 |
| Wing tip tanks (2 @ 244 gallons) | | 488 | 3,757 | 3,904 |
| <i>Total, all tanks</i> | | 2,765 | 21,290 | 22,120 |
| Bomb bay overload tank (Not in interdictor role) | | 300 | 2,310 | 2,400 |
| Total overload | | 3,065 | 23,600 | 24,520 |

NOTE.—The capacity of No. 3 tank may be somewhat less than quoted until the bag stretches with use.

- (b) Five capacitor-type gauges calibrated in lb. are on the engine instrument panel. The upper gauge indicates the contents of No. 1 tank, the centre gauges from left to right indicate the contents of the port integral, No. 2 and the starboard integral tanks respectively and the lower gauge indicates the contents of No. 3 tank. No contents gauges are provided for the wing tip tanks or the bomb bay overload tank.

5. Low pressure (L.P.) and transfer cocks

- (a) A pair of electrically-operated L.P. cocks is fitted for each fuselage tank. Of each pair one serves the port engine and

PART I—DESCRIPTIVE

the other the starboard engine. Two electrically-operated cocks are fitted for each integral tank, one for normal delivery to the engine and the other for transferring fuel to the No. 3 tank. The integral L.P. and transfer cocks are interconnected in such a way that when the transfer cock is open (i.e. to transfer fuel) the L.P. cock is closed.

- (b) Each L.P. cock and transfer cock is controlled by one of ten switches (appropriately labelled) on the take-off panel (fig. 2) and their circuits are protected by circuit-breakers (6, 7, 8 and 9) on the front face of the electrical control panel.

NOTE.—The engines should not be stopped by switching off the L.P. cocks as this causes the engine-driven pumps to run dry and air to be drawn into the pipe lines.

6. Low pressure (L.P.) booster pumps

- (a) Two electrically-driven L.P. pumps are fitted in each fuselage tank and one in each integral tank. The pumps on the port side of the fuselage tanks feed fuel through their associated L.P. cocks and a common collector box to the port engine H.P. pump (see para. 10); similarly, the pumps on the starboard side of the tanks feed the starboard engine H.P. pump. The pump in each integral tank feeds fuel either direct to its associated engine or to No. 3 tank depending on the selected position of the transfer cock (see para. 5 (a)).

- (b) Each pump is controlled by one of eight switches (at 75, 72, 70 and 69) on the engine instrument panel and their circuits are protected by circuit-breakers (6, 7, 8 and 9) on the front face of the electrical control panel. The switches for the integral and No. 3 tanks are guarded to prevent inadvertent OFF selections.

7. Fuel pressure warning lights

Two fuel pressure warning lights (73 and 71), one for each engine, are at the bottom of the engine instrument panel. They come on if fuel delivery pressure from the booster pumps fall appreciably below normal due to pump failure, negative G or shortage of fuel in the tank(s) in use. For the effect of booster pump failure see para. 90(g).

8. **Oil system**

- (a) Each engine has its own integral oil system, the capacity of which is approximately 17 pints. One pressure and two scavenge pumps maintain a continuous circulation through a cooler and filters to the engine bearings and gears. The filler cap is on the port side of the engine accessible through a removable panel in the lower cowling.
- (b) Oil pressure gauges, one for each engine, are on the engine instrument panel; these register whenever A.C. supply to the instruments is available (see para. 28).

ENGINE CONTROLS

9. **Throttle controls**

The two throttle levers (29) are on the engine controls quadrant. Friction adjustment is by the larger (32) of two knurled knobs (turn clockwise to increase friction) on the side of the quadrant. The starboard throttle on B.(I)6 aircraft incorporates a V.H.F. press-to-transmit pushbutton.

10. **High pressure (H.P.) fuel pumps**

- (a) The total output of the dual engine-driven H.P. fuel pump on each engine is limited by a servo-control system and a governor on each pump limits overspeeding of the engine.
- (b) Control of the fuel flow is effected by:—
- The throttle to meter fuel to the burners.
 - A barometric pressure control (B.P.C.) to vary the pump output in relation to engine intake pressure.
 - An acceleration control unit (A.C.U.) to prevent excess supply of fuel to the engine during periods of engine acceleration.

Both the A.C.U. and B.P.C. are connected to the servo-control system.

- (c) Each pump of the dual pump units is capable of supplying sufficient fuel for full thrust at take-off.

11. **High pressure (H.P.) fuel cocks**

The H.P. cocks, one for each engine, are controlled by levers (34) outboard of the throttles. They may be locked

in either the ON (forward) or OFF position by the smaller of the two knurled knobs (33) (turn clockwise to lock) on the side of the engine controls quadrant. In the OFF position the fuel supply to the burners is cut off. The levers each incorporate a relighting pushbutton.

12. **Variable-pitch guide vanes and air bleed valves**

- (a) The first row of stator blades in the engine compressor consists of variable pitch inlet guide vanes which assist in imparting swirl to the incoming air. At low r.p.m. the first stages of the compressor deliver more air than is acceptable to the later stages. To prevent instability of flow, i.e. surge, the surplus air is bled off through air bleed valves, and the guide vanes are held closed to give an angle of flow acceptable to the first stage blades at low r.p.m. As the normal flight range of r.p.m. is reached, the air bleed valves close and the guide vanes move progressively to the minimum swirl position.
- (b) No noticeable change in r.p.m. or thrust occurs when the bleed valves change over nor do the guide vanes have any noticeable effect on engine operation. However, until the guide vanes reach the fully open position at about 7,250 r.p.m., the compressor is not operating at maximum efficiency. Better specific fuel consumption therefore, will be obtained by operating above 7,250 r.p.m.

13. **Engine starting, relighting in flight and stopping controls**

- (a) Each engine is fitted with a triple-breech cartridge turbo starter. A MASTER STARTING switch (85), starter pushbutton (84 and 78) and ignition switch (83 and 80) for each engine, are on the engine starter panel. The master starting switches must be ON before either the starter pushbuttons or ignition switches are operative.
- (b) With the turbo-starter loaded, master starting and ignition switches ON, pressing the starter pushbutton initiates the following sequence:—
- Indexing and firing the cartridge to accelerate the engine to approx. 1,700 r.p.m.
 - Energising the high energy ignition plugs to ignite the fuel spray and make the engine self-sustaining.

A time-delay switch holds the starter pushbutton in until the sequence is complete.

PART I—DESCRIPTIVE

- (c) The relighting pushbuttons on the H.P. cock levers are for relighting the engines in flight. Pressing the appropriate button by-passes the normal starting circuit and immediately energises the high energy ignition plugs. Neither the master starting or ignition switches need be ON.
- (d) The engines are stopped by pulling back the H.P. cock levers (34) to close the H.P. cocks.

14. Engine instrument panel

The fuel contents gauges, booster pump switches, fuel pressure warning lights (73 and 71), r.p.m. indicators, oil pressure gauges and a dual jet pipe temperature (j.p.t.) gauge (58) are on the engine instrument panel.

15. Engine anti-icing system

Hot air for engine anti-icing is ducted from the engine compressor, into the double skin at the front of the engine cowl, the engine intake casing and the turbo-starter casing. The systems are controlled by two ON-OFF switches (41) one for each engine, on the port console. Magnetic indicators beside the switches show white when the systems are switched on.

NOTE.—A few early aircraft may still be fitted with three-position switches labelled OFF-AUTO-EMERGENCY. The AUTO position must *not* be used. When anti-icing is required switch to EMERGENCY.

16. Engine fire extinguishers and warning lights

- (a) Two fire-extinguisher bottles are fitted, one in the port wheel well serving the port engine and one in the starboard wheel well serving the starboard engine. With Mod. 1403 embodied an additional bottle is provided for each engine. Each bottle is fully discharged in one operation.
- (b) Fire-extinguisher pushbuttons (60) incorporating fire warning lights, one for each engine, are on the miscellaneous instrument panel. These buttons also fire the additional bottles, when fitted. The warning lights come on to indicate engine fire and remain on until the fire is extinguished by operation of the appropriate extinguisher. They may be tested by pulling out the pushbuttons but they must not

PART I—DESCRIPTIVE

be allowed to snap back as this may discharge the bottles. Mod. 1778 introduces a separate pushbutton above the fire-extinguisher pushbuttons for testing the warning lights.

- (c) In the event of a crash landing and consequent operation of the inertia crash-switches (see para. 26) all the bottles are discharged.

HYDRAULIC SYSTEM

17. Hydraulic pumps and services

- (a) A hydraulic pump on each engine draws fluid from a reservoir (capacity 2 galls.) at the starboard side of the upper equipment bay. A stackpipe in the reservoir ensures a reserve of fluid for use with the handpump. From the engine-driven pumps fluid is delivered to the system for operating the:—

- Undercarriage
- Flaps
- Wheel brakes
- Airbrakes
- Bomb doors

- (b) A handpump to the right of the pilot's seat, works in conjunction with the hydraulic GROUND/FLIGHT cock situated near the front of the bomb bay roof on the starboard side. When the cock is at FLIGHT the handpump can be used to operate only the undercarriage and the bomb doors and to charge the brake accumulator. With the cock at GROUND the handpump can be used to operate all services. The cock is normally wire-locked in the FLIGHT position. When not in use the handpump handle is stowed in clips above and aft of the entrance door.

18. Hydraulic accumulators

- (a) There are two hydraulic accumulators in the system; the one for the wheel brakes is in the fuselage just forward of the bomb bay and that for the undercarriage, flaps, airbrakes and bomb doors is in the starboard wing. The air pressure gauge for the brake accumulator is in the bomb bay on the forward bulkhead and that for the wing mounted accumulator is in the starboard wheel well. These

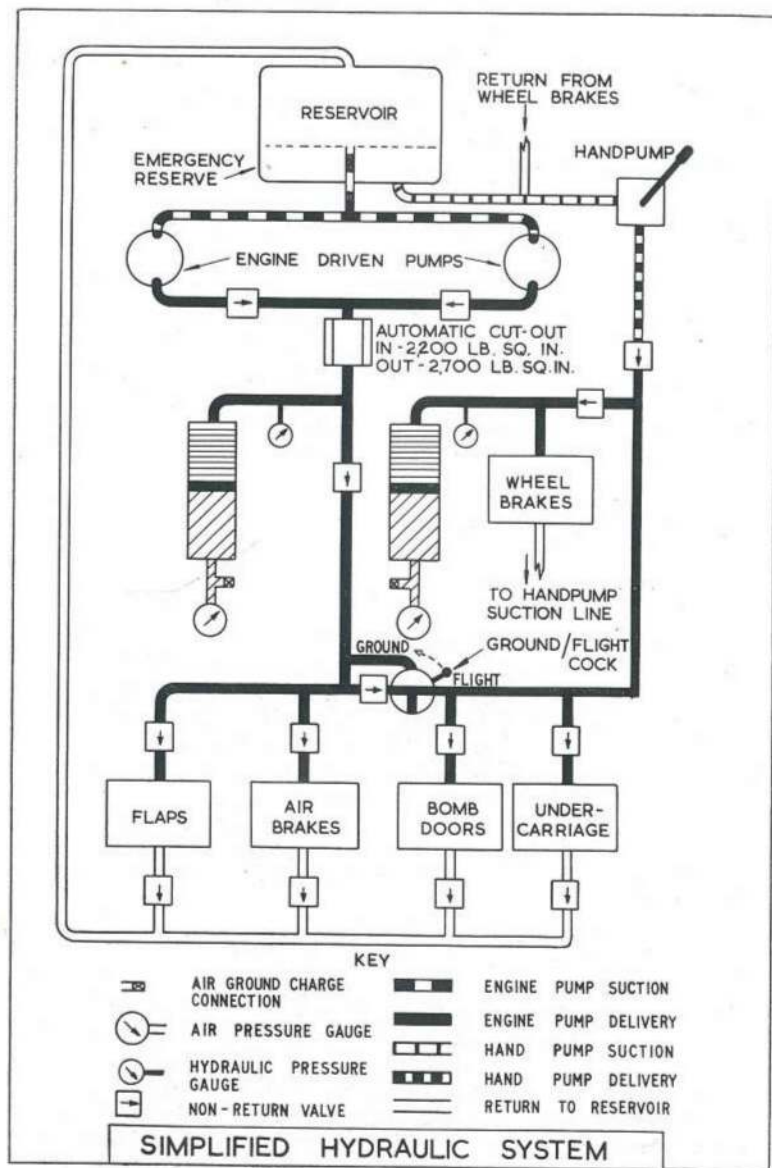

gauges should read 1,350 lb./sq. in. when there is no pressure in the hydraulic system. The hydraulic pressure gauges (65 and 66), one for each accumulator, are on the miscellaneous instrument panel.

- (b) A cut-out in the hydraulic pump delivery circuit maintains the working pressure in the accumulators and system at 2,200 to 2,700 lb./sq. in. while thermal relief valves, suitably positioned in the circuits, operate when pressure in the line to a service increases for any reason to more than 3,000 to 3,500 lb./sq. in.

19. Hydraulic services control

The electrically-actuated selector valves for all services other than the wheel brakes, which are mechanically operated, are controlled by switches in the cockpit. If electrical failure occurs, provision is made for mechanical selection of undercarriage lowering and bomb doors opening. Details of all these controls are given in the relevant paragraphs.

ELECTRICAL SYSTEM—24 volt

A.L.1
Page 19
Paras.
20, 21

20. General

D.C. power for the electrical system is supplied by two 6 kW generators operating in parallel and the aircraft battery, four 12-volt 40 amp. hr. batteries connected in series-parallel. Aircraft with Mod. 2155 or 2393 embodied have two 9 kW generators performing the same service. By means of rotary inverters, power supplies of 400 c/s 3-phase A.C. and 1,600 c/s single-phase A.C. are provided for operating the flight instruments and radar equipment.

21. Generators

- (a) *Pre and post-Mod. 2155 or 2393*

The generators, one on each engine, cut in at an engine speed of approximately 1,700 r.p.m. and cut out at slightly below this figure. Full output is maintained at r.p.m. in excess of 3,000.

- (b) *Pre-Mods. 2155 and 2393*

Each generator has an ON/OFF switch (4 and 5) and a field circuit breaker (at 3) on the rear face of the electrical control panel, and a failure warning lamp (88) on the voltmeter panel (see para. 22).

- (c) *Post-Mod. 2155 or 2393*

There are no control switches in the cockpit and the field circuit breakers, on the main electrical panel in the starboard equipment bay, are inaccessible in flight. Failure warning lights are as at (b) above.

22. Voltmeter panel

(a) A voltmeter panel, carrying two generator failure warning lights (88) and a D.C. voltmeter (87) is on the starboard cockpit wall above the entrance door. The warning lights come on when the generators are off line or to indicate generator failure. The D.C. voltmeter registers as follows:—

- | | | |
|--|---|-----------|
| (i) Generator(s) charging | Generator(s) voltage (normally 27.5 volts) <i>28</i> | |
| (ii) Generators off line— battery isolating switch ON | Aircraft battery voltage (normally 24 volts) | <i>Av</i> |
| (iii) Generators off line— battery isolating switch OFF—external battery plugged in | External battery voltage (normally 24 volts) | |

23. Aircraft battery

The aircraft battery, located in the lower equipment bay access to which is through a hinged hatch on the port side of the fuselage, has an isolating switch on the take-off panel (fig. 2). With this switch ON, the battery is connected to the electrical system and is kept charged by the generator(s) or is available for use with the generator(s) off line; when switched OFF, the battery is isolated from the electrical system with the exception of the following emergency circuits:—

| | |
|------------------------------|----------------------|
| Inertia crash-switch circuit | } detonator circuits |
| Fire-extinguisher circuits | |
| Bomb jettison circuits | |
| Escape hatch | |
| Canopy | |
| Elevator control | |

24. External battery socket

An external battery socket is on the main electrical panel in the starboard equipment bay access to which is through the door aft of the entrance door. Before connecting an external supply, the aircraft battery must be isolated from the electrical system. All electrical services may then be operated from the external supply.

25. Emergency batteries

- (a) A separate 24-volt battery, located in the port console, is directly connected to the detonator circuits (see para. 23), so that these circuits remain operative if the aircraft battery is disconnected. It may also be used to operate the turn-and-slip indicator if the normal supplies have failed but its use in this case must be limited to ensure that the operation of the detonator circuits is not prejudiced.
- (b) A separate 2.4 volt battery located just forward of the rudder pedals, supplies the pilot's instrument panel emergency lamps. Used continuously, it will last approximately two hours.

26. Inertia crash-switches

Pendulum-type inertia crash-switches are located one each in the port and starboard equipment bays. When triggered off they operate the fire-extinguishers (see paras. 16 (c) and 81 (b)) and isolate the aircraft battery from the electrical system, with the exception of the emergency circuits quoted in para. 23, irrespective of the setting of the battery isolating switch.

27. A.C. supply

A.C. is supplied by four inverters: the distribution of power is given in the following table:

| Inverter | Supply to | Stand-by |
|--------------------------|--|----------|
| No. 2 115 V-400 c/s | Artificial horizon Mk. 4B compass Oil pressure indicators | No. 3 |
| No. 3 115 V-400 c/s | Bomb sight head Bomb sight computer Rear warning head cooling No. 5 inverter cooling Stand-by for No. 2 inverter | None |
| No. 4 115 V-1,600 c/s | Stand-by for No. 5 inverter but only operates Gee receiver or Rebecca | None |
| No. 5 115 V-1,600 c/s | Gee-H Rear warning Rebecca | No. 4 |

PART I—DESCRIPTIVE

28. Control of inverters

- (a) No. 2 and No. 3 inverters are initially controlled by switches coupled to the starboard and port MASTER STARTING switches respectively and are always running when these switches are ON. However, irrespective of the position of the port MASTER STARTING switch, No. 3 inverter starts up automatically if No. 5 inverter is started to ensure that the radar blower motors are running.
- (b) No. 4 and No. 5 inverters are controlled by four switches (at 2) on the rear face of the electrical control panel. These comprise, a No. 4 inverter ON/OFF switch, a No. 4/No. 5 inverter change-over switch and No. 5 inverter START and STOP switches.

NOTE.—1. No. 5 inverter must not be started unless at least one generator is charging at 28 volts.

2. Neither radar inverter must be started on load i.e. the various services supplied by these inverters must be off.

- (c) Three ON/OFF switches (at 1) below the radar inverters control switches, labelled for their respective service, distribute the output of the radar inverters, in addition to D.C. supply, to the individual equipment.
- (d) Of the four circuit-breakers below the rear face of the electrical control panel, three protect the input to No. 2, No. 3 and No. 4 inverters, while the other, the 1,600 c/s circuit-breaker, protects No. 5 inverter control circuit and the supply to the radar circuits. The input to No. 5 inverter is protected by a circuit-breaker in the starboard equipment bay.

29. Inverter failure

- (a) Failure of No. 2 inverter is shown by the EMERGENCY INST SUPPLY indicator (55) on the instrument panel showing white by day and fluorescent at night. At the same time No. 3 inverter automatically takes over the supply to the A.C. operated flight instruments and the oil pressure indicators.
- (b) On some aircraft a phase failure-indicator (91) may be fitted to the voltmeter panel. This automatically indicates the output of No. 2 or No. 3 inverter whichever is supplying the flight instruments or, when a No. 2/No. 3 inverter

PART I—DESCRIPTIVE

selector switch (90) is provided, the output of whichever inverter is selected on the switch. When the inverters are operating normally the output needle registers in the white sector; failure is indicated by the needle dropping into the red sector.

NOTE.—1. If both No. 2 and No. 3 inverters fail there will be no supply to the A.C. operated flight instruments and the oil pressure indicators.

2. If No. 3 inverter fails there will be no supply to the radar cooling motors and ~~apart from short periods of operation~~, No. 5 inverter will have to be switched off. A21

- (c) If No. 5 inverter fails it should be switched off and, after selecting the change-over switch to No. 4 inverter, No. 4 inverter switched on to provide the A.C. supply. However, as No. 4 inverter operates at a reduced output, automatic isolation of the rear warning device and the Gee-H equipment is provided. Both the Rebecca and the Gee receivers remain operative but only one of these aids should be used at a time to prevent overloading No. 4 inverter.

30. Circuit-breakers and fuses

- (a) All the circuit-breakers have been covered with their associated equipment.
- (b) Fuses for individual services are behind a detachable panel on the side of the electrical control panel and behind a panel marked FUSES on the port console. A list of these fuses is on the back of each panel.

AIRCRAFT CONTROLS

31. Flying controls

- (a) The flying controls are conventional and the rudder pedals are adjustable for reach by a central star wheel. Two different control column handwheels are available according to the aircraft role.
- (i) In the bomber role (B.6) the control column handwheel carries the wheelbrakes lever and parking catch, a tailplane incidence control and master cut-in pushbutton (Mod. 1929), a V.H.F. press-to-transmit pushbutton, the airbrakes control switch and a bomb release pushbutton.

PART I—DESCRIPTIVE

Control Column Handwheel (B.6)

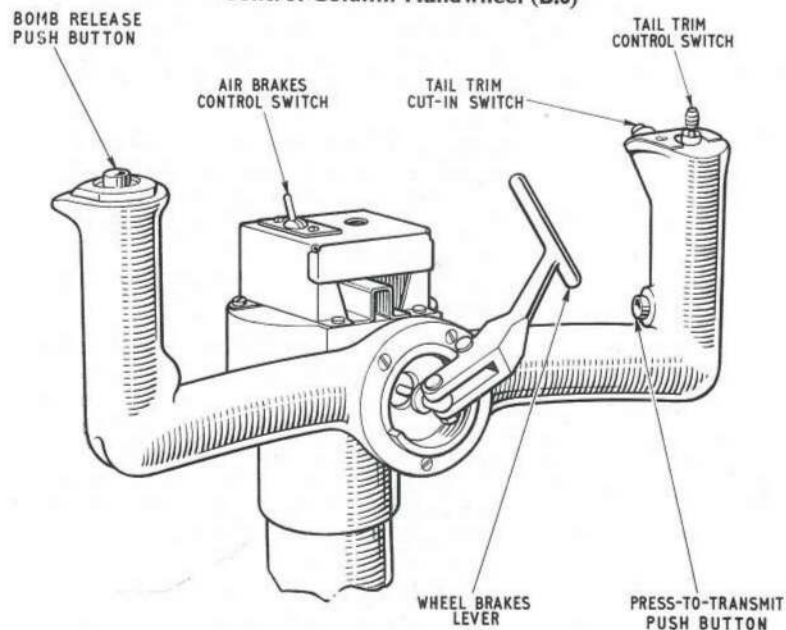

Control Column Right-hand Grip (B.(I)6)



PART I—DESCRIPTIVE

- (ii) In the interdicator role (B.(I)6), the control column handwheel carries the wheelbrakes lever and parking catch and the airbrakes control switch. The right-hand grip carries a gun-firing trigger, bomb release or rocket firing button, a camera button and a tailplane incidence control switch covered by a thumb operated master cut-in switch (Mod. 1923).

32. Flying controls locking gear and picketing points

(a) External locks

All control surfaces are locked by external clamps with red flags attached. When not in use the clamps are stowed in a valise in the rear fuselage accessible through the camera hatch. (See also para. 36 (b).)

(b) Picketing

Ring bolts are provided for picketing; they are stowed with the control locking clamps and screw into sockets covered by flaps labelled PICKETING POINT on each main undercarriage fairing and below the fuselage aft of the rear skid. A fourth picketing attachment is provided by the radius lugs on the nosewheel strut.

33. Variable incidence tailplane and trimming controls

- (a) Changes in tailplane incidence are made by an electrical actuator controlled by a switch (spring-loaded off) on the control column handwheel. The switch is moved forward on the B.6 and up on the B.(I)6 to give a nose-down trim change and back on the B.6 and down on the B.(I)6 to give a nose-up trim change. The limits of the tailplane travel are controlled by electric limit switches: if these fail the actuator will run on slightly until stopped by positive mechanical stops.
- (b) On B.6 aircraft Mod. 1929 introduces a master cut-in switch (spring-loaded off) just forward of the tail trim switch: on the B.(I)6 (Mod. 1923) it consists of a thumb operated flap (spring-loaded off) over the tail trim switch. In both cases the cut-in switch controls a master relay in the power circuit of the tailplane actuator so that until it is operated no current can reach the actuator irrespective of any selection of the tail trim switch (see also para. 105 (c) and (d)).

PART I—DESCRIPTIVE

- (c) With Mod. 2125 embodied the amount of available tailplane trim is limited so that the aircraft is controllable under any flight conditions within the limitations if the actuator runs away to the fully nose-down trim position. This applies even if the actuator has overrun the electrical limit switches and has reached the mechanical stops (see (a) above). Adjustments to the elevator trailing edge strips included under this Mod. ensure that, if the actuator has run away to the fully nose-down trim position, the aircraft will be in trim longitudinally at a speed between 425 and 450 knots.

A.L.I.
Page 26
Para. 33
(d), (e)

(d) Both ailerons, the port elevator and the rudder are fitted with spring tabs. The rudder spring tab also operates as a trim tab. Lateral trimming is by an aileron bias gear in the form of a spring to preload the control column handwheel in either direction. The rudder and aileron trimmers, electrically operated, are each controlled by a switch (37 and 38) on the port console. With Mod. 2193 embodied, the rudder trim switch is replaced with two switches, one controlling the power supply and one the earth return, so that both switches must be operated simultaneously to obtain rudder trim movement.

(e) Position indicators (46, 45 and 42) for all three trimming controls are on the main instrument panel.

34. **Undercarriage controls and indicator**

- (a) Two UP-DOWN pushbuttons (28) on the port front panel control the electrical actuator for the undercarriage selector valve. An electrically-operated lock prevents normal operation of the UP button when the weight of the aircraft is on the wheels but this lock may not function when the aircraft weight is low. The lock can be overridden by turning the UP button clockwise through 90° before selecting undercarriage UP in the normal way. This override must not be used in flight as there is a risk of the oleo leg being raised when not fully extended.
- (b) B.C. Mod. 59 or Mod. 2364 introduces an U/C SAFETY SWITCH on the take-off panel. This switch must be up before undercarriage UP can be selected.
- (c) A standard undercarriage position indicator (27) is beside the undercarriage selector buttons. The red nosewheel light comes on in flight if either throttle is less than one-third open with the undercarriage locked up.

35. **Undercarriage emergency lowering control**

Should the undercarriage selector valve fail to operate electrically to lower the undercarriage, it may be operated

PART I—DESCRIPTIVE

mechanically by pulling the toggle handle (24) on top of the port front panel. If the undercarriage is lowered in this way it cannot be raised again until serviced: therefore it must first be established that the fault is in the selector valve and not due to hydraulic failure (see para. 129).

36. **Flap control and indicator**

- (a) The electrically-actuated flap selector valve is controlled by a two-position, fully UP or fully DOWN, switch lever (26) on the port front panel: the position indicator (23) is adjacent to the switch lever. No provision is made for in flight operation of the flaps in the event of electrical or hydraulic failure.
- (b) To prevent inadvertent operation of the flaps when external locks are fitted, a locking pin is inserted in the switch lever guard. When not in use, this pin is stowed in a bag on the lower front face of the electrical control panel.

37. **Airbrakes control**

A three-position, IN-MID-OUT switch controlling the actuator for the airbrakes is on top of the control column. The switch may be fitted with a spring-loaded guard so that this must be moved before OUT can be selected. No provision is made for in flight operation of the airbrakes in the event of electrical or hydraulic failure.

38. **Wheel brakes control**

- (a) The hydraulic wheel brakes are operated by a lever on the control column. A parking catch is provided. Differential braking is obtained by movement of the rudder bar. Anti-skid (Maxaret) units are fitted which allow the maximum braking power to be used without locking the wheels (see para. 113).
- (b) The inboard gauge (66) of the two hydraulic pressure gauges on the miscellaneous instrument panel shows the available brake pressure in the brake accumulator. Normally 2,200-2,700 lb./sq. in., this pressure allows several full applications of the brakes if the main system has failed, and in this event the pressure will fall to 1,350 lb./sq. in. as the brakes are used. At this point the accumulator is discharged of hydraulic fluid and pressure will drop rapidly to zero. Pressure may, however, be restored by means of the handpump, provided that fluid is available.

FLIGHT INSTRUMENTS

39. Pitot and static pressure systems

An electrically-heated pressure head on the nose and two static vents, one on each side of the nose, supply pitot and static pressure respectively for the machmeter, A.S.I.s, altimeters, V.S.I. and zero reader as applicable. The heater element in the pressure head is controlled by a switch on the take-off panel.

40. Compasses

(a) *Mk. 4B compass*

The Mk. 4B compass is operated whenever A.C. is supplied by either No. 2 or No. 3 inverter. The master indicator and control panel are at the navigator's station. The pilot's repeater, on the main instrument panel, may also be used as a directional gyro by setting the COMPASS-D GYRO switch (77), on the engine starter panel, to D GYRO.

(b) *Standby compass*

An E.2 standby compass covered by a hinged EMERGENCY COMPASS flap (56) is fitted centrally on the forward coaming.

41. Artificial horizon

Either a Mk. 3 or a Mk. 4C artificial horizon may be fitted on the main instrument panel. In either case, the instrument will be operated whenever A.C. is being supplied by either No. 2 or No. 3 inverter and will have a fast-erection pushbutton below and to the left of it.

42. Turn-and-slip indicator

The turn-and-slip indicator on the main instrument panel is operated from duplicated 24-volt D.C. supplies having automatic change-over. Both supplies are primarily controlled by the MASTER STARTING switches. Should both normal supplies fail, the instrument may be connected to the emergency battery (see para. 25 (a)) by switching the guarded switch (81) beside the indicator to EMERGENCY.

43. Accelerometer

An accelerometer (74) may be fitted below the engine instrument panel.

44. Radio altimeter

- (a) The radio altimeter (47) and the height band selector (86) are on the main instrument panel while the limit lights (44) are on the inboard side of the port front panel. In some aircraft the height band selector is replaced by an I.L.S. indicator, in which case, the height band selector is moved to a panel on the cockpit starboard wall above the entrance door.
- (b) The master switch for this equipment is at the navigator's station.

45. Instrument landing system (I.L.S.)

When I.L.S. equipment is installed, the indicator is on the instrument panel (see para. 44) while the control unit and master switch are on the port wall at the navigator's station.

46. Zero reader

When a zero reader is installed, the indicator is fitted above the A.S.I. and the course selector is fitted below the Mk. 4B compass, both on the main instrument panel, while the control panel is on the cockpit starboard wall above the entrance door.

AIR-CONDITIONING, PRESSURISING,
HEATING AND DE-MISTING SYSTEMS

47. Air-conditioning and pressurising

(a) *Air-conditioning*

- (i) Hot air from the engine compressors is used for cabin air-conditioning. The initial supply from each compressor is through an electrically operated gate-valve controlled by one of two ENGINE AIR SWITCHES (68) on the miscellaneous instrument panel.
- (ii) The temperature of the air entering the cabin is governed by a mixing valve controlled by a COLD-HOT switch (67), spring-loaded to the mid (off) position on the miscellaneous instrument panel. The setting of the mixing valve is shown on an indicator (62) labelled CABIN AIR, above the control switch.

PART I—DESCRIPTIVE

- (iii) With the mixing valve set to fully HOT, the hot air from the compressors is passed direct to the cabin. By moving the mixing valve to fully COLD, the hot air is passed through coolers, one in each inner plane leading edge and a cold air unit in the port inner plane and thence into the cabin. The proportion of air can be varied between the two extremes by setting the mixing valve to any desired intermediate position.
- (iv) From the common delivery duct into the cabin, the conditioned air is delivered to various parts of the cabin by branch pipes terminating at four louvres, which may be shut off, and five diffusers. Three of the louvres are at the pilot's station one (76) on the rudder pedal guard, one (30) on the port front panel and one on the coaming above the entrance door; the remaining louvre is on the port wall at the navigator's station. A diffuser is located forward of each crew member's feet and of the remaining two, one (17) is on the cockpit port wall and the other is on the inboard edge of the navigator's instrument panel. The diffusers cannot be shut off but the flow of the latter two is controllable by rotating the diffuser head.
- (v) When a ventilated suit system is installed air for the system is piped from the transverse pipe between the mixing valve and the primary cooler to a shut-off valve and a quick release connection at each ejection seat. The pilot's shut-off valve (13) is on the port console.
- (vi) A supply of ventilating air is provided via a small air scoop forward of the canopy and ducted to a louvre (43) on the inboard side of the port front panel; the supply may be cut off at the louvre. The system incorporates a simple non-return valve to prevent loss of cabin pressure.

(b) *Pressurising*

- (i) At about 10,000 feet a master unit and a combined valve unit, which regulates the outlet of air from the cabin according to static pressure, work in conjunction to allow the air-conditioning system to build up cabin pressure with increasing altitude until a maximum differential pressure of 3.5 lb./sq. in. is reached at about 25,000 feet; above this height the differential

PART I—DESCRIPTIVE

pressure is constant. The cabin altitude is shown on an altimeter (64) on the miscellaneous instrument panel.

- (ii) Electrical contacts in the master unit operate a warning horn if the cabin pressure drops excessively. Approximate figures giving the normal height differential and the cabin altitude at which the warning horn will sound are given in the following table. A guarded warning horn over-ride switch (63) is adjacent to the cabin altimeter.

| Aircraft altitude (ft.) | Cabin altitude (ft.) | Cabin altitude at which warning horn sounds (ft.) |
|-------------------------|----------------------|---|
| 20,000 | 12,000 | 15,300 |
| 30,000 | 16,500 | 21,800 |
| 40,000 | 21,500 | 28,000 |
| 45,000 | 23,500 | 31,000 |

- NOTE.—1. No air will be supplied for either air-conditioning or pressurising unless the engine air switches are ON.
- 2. If a fault develops in the air supply from an engine or if an engine fails or is closed down the appropriate engine air switch should be switched OFF.

48. **Heating**

(a) *Camera bay*

Hot air from the air-conditioning system is ducted to a diffuser in the camera bay through an automatically-operated temperature control valve. The heating system also prevents misting of the camera window and the camera lens.

(b) *Gun pack B.(I)6*

The gun pack is heated by disconnecting the hot air supply to the camera bay and connecting it to the gun pack heater pipe.

PART I—DESCRIPTIVE

49. Demisting

(a) *Canopy, navigator's window and plastic nose*

The entire canopy, the navigator's window and the plastic nose are of the "dry air" sandwich type. Two static air driers are fitted; that for the plastic nose and bomb-sight window is mounted just aft of the nose fairing and the other for the canopy is mounted on the coaming behind the pilot's right shoulder. A third drier for the canopy circulation system and, in a static role, for the navigator's window, is mounted on the coaming behind the pilot's seat. Air in the closed canopy/air drier circuit, is circulated by a small electrically-driven fan controlled by a CANOPY DE-MISTER switch on the take-off panel. Small indicator windows in the drier casings enable the drying agent to be seen; this will appear buff-coloured in the nose static and canopy circulation drier and pink in the canopy static drier if it is unserviceable.

(b) *Direct-vision (D.V.) panel*

An electrically-heated direct vision panel is in the canopy on the port side; the heater switch is on the take-off panel. When the cabin is unpressurised the D.V. panel can be opened by unscrewing the knurled clamping knob and hinging the frame downwards to engage in the retaining clip.

(c) *Canopy (internal)*

Hot air from the air-conditioning system is fed through a control valve and diffuser on to the forward inner surface of the canopy. The flow may be regulated by means of the knurled DEMIST-ON knob (22) above the take-off panel.

(d) *Bomb-sight window*

Conditioned air is automatically fed on to the bomb-sight window whenever the air-conditioning system is in use.

OXYGEN SYSTEM

50. Oxygen supplies and contents gauges

Oxygen is carried in two 2,250 litre and five 750 litre bottles stowed in the upper equipment bay. A connection in the lower equipment bay, accessible through a hinged hatch on the port side of the fuselage, allows the bottles to

PART I—DESCRIPTIVE

be charged in situ. The bottles are arranged in two banks each having a separate supply line: these lines, after passing through stop valves (normally wire-locked on) one on each side of the rear pressure bulkhead outboard of the ejection seats, are interconnected through non-return valves so that, while each bank can supply all the regulators independently, fracture of one supply line will not cause a total loss of oxygen. Two gauges (92) above the entrance door indicate the contents in each bank of bottles.

51. Oxygen regulators and crew supply points

(a) The supply of oxygen to the crew supply points is controlled by the regulators: these may be Mk. 17, Mk. 17C or Mk. 17D. In any case, pressure demand masks Type A13A/1 or 2 must be worn.

(b) The pilot's regulator (15) is on the cockpit port wall, the navigator's is above the instrument panel at his station and of the bomb-aimer's two, one is on the starboard wall at his rear station and the other is on the starboard wall at his nose station. With Mk. 17C and Mk. 17D regulators, there is a remote blinker flow indicator (53) on the main instrument panel for the pilot's regulator, and, on some aircraft, another for the bomb-aimer's nose-station regulator under the front starboard coaming. When oxygen flow ceases the relevant indicator remains black.

(c) Supply tubes from the pilot's and rear station regulators terminate at quick release sockets on the right-hand side of the ejection seats. The flexible supply tube from the nose station regulator terminates at a quick release socket with a rubber stopper. This socket is located in a clip on the starboard wall at the bomb-aimer's rear station and thus allows the bomb-aimer to disconnect from his ejection seat supply and connect to his nose station supply before moving to his nose station. As the nose-station regulator will normally be turned on before take-off, the rubber stopper must be fitted at all times when the supply is not in use to prevent loss of oxygen.

52. Oxygen emergency supplies

(a) Each ejection seat parachute pack carries an emergency oxygen bottle which is pipe connected to the quick release socket of the oxygen mask before flight. If the main system

PART I—DESCRIPTIVE

fails the emergency supply can be made available by pulling up on the operating cable conduit or down on the ball on the operating cable, both on the right-hand side of the seat pan. As it is more easily accomplished, the former method is recommended. The emergency bottle is operated automatically when the ejection seat is fired.

- (b) An emergency oxygen bottle is also fitted at the bomb-aimer's nose station.

RADIO AND RADAR EQUIPMENT

53. V.H.F.

The V.H.F. installation consists of two 10 channel transmitter-receivers, TR.1985-TR.1986. The channel selectors, volume control and change-over switch (82) are at the bottom of the main instrument panel. The press-to-transmit pushbutton is on the right-hand grip of the control column handwheel on the B.6 and on the starboard throttle on the B.(I)6.

A.L.1
Page 34
Para. 54

54. Intercomm.

(a) Intercommunication is by amplifier A.1961 with the V.H.F. as an emergency standby. The ON-OFF switch and NORMAL-EMERGENCY changeover switch are on the take-off panel. There are five mic/tel sockets, one on the left of each ejection seat back, one to the right of the pilot's seat for use with the folding seat and one at the bomb-aimer's nose station. With Mod. 2391 embodied, an extension lead, from the nose station socket, is clipped to the oxygen wander lead so that the bomb-aimer can remain on intercom. when moving to and from his nose station.

(b) An external intercom. socket is on the side of the fuselage in the starboard wheel well.

55. Radio altimeter, I.L.S. and zero reader

The above equipment is covered under FLIGHT INSTRUMENTS at paras. 44, 45 and 46 respectively.

56. H.F. equipment

When H.F. equipment (S.T.R. 18B2) is installed the main controls are at the bomb-aimer's rear station but the pilot may transmit and receive on the equipment using his V.H.F. press-to-transmit pushbutton with a suitable selection on the H.F./V.H.F. mixer box on the cockpit port wall.

PART I—DESCRIPTIVE

57. Radio compass

When a radio compass is installed, the controller, main bearing indicator and master switch are normally at the navigator's station, although in some cases the controller may be duplicated on the port console. In either case, the pilot's bearing indicator (49) will be on the main instrument panel, and his mixer box (19) will be on the cockpit port wall. A PRESS TO CALL NAV switch (18) may also be provided on the cockpit port wall for use when the navigator is using the radio compass.

58. Gee-H and Rebecca equipment

The control units for the Gee-H and Rebecca equipment are at the navigator's and bomb-aimer's stations and the master switches (at 1) are on the rear face of the electrical control panel. The pilot's indicator for the Gee-H consists of three small lamps (79) at the bottom right of the main instrument panel.

59. Rear warning

The control unit (14) for this equipment is on the cockpit port wall and the visual indicator (52) is on the main instrument panel. Audible warning is also given on the pilot's headphones.

GENERAL EQUIPMENT AND CONTROLS

60. Entrance door

(a) The entrance door is on the starboard side of the fuselage aft of the nose fairing. To open the door from either inside or out, press the red painted plunger adjacent to the flush fitting handle; this allows the handle to spring out, which is then turned anti-clockwise from the outside and clockwise from the inside. The door should not be opened in this way in flight. The door is supported in the open position by a hinged strut which is attached to the door and located in a socket in the door aperture framing.

(b) The entrance door may be jettisoned by turning the crank (93) fitted centrally above it; this releases the hinge pins allowing the door to fall outwards. The crank may be stiff to operate and four and a half full turns are required.

PART I—DESCRIPTIVE

61. Folding seat

A folding seat is secured to the cockpit starboard wall just aft of the entrance door by a hinged bracket which allows the seat to be folded against the wall where it is secured by a strap. A webbing back-rest and a safety harness for use with the seat are also provided. The lap straps are secured to the seat and the shoulder straps are secured to the top fuselage crossmember.

62. Internal lighting

(a) Nose-station

The nose-station is illuminated by a dome lamp with an integral switch and a 2-pin socket. An adjustable lamp is also fitted for use with the bombing instruments.

(b) Cockpit

(i) General illumination of the main instrument panel is provided by four U/V and seven red flood lamps, while individual lamps illuminate the stand-by compass, No. 3 tank fuel gauge and with Mod. 1459 embodied, the oxygen contents gauges. The lamps are controlled by four dimmer switches fitted on the coaming above the instrument panel, two (50 and 59) for the U/V lamps and two (51 and 57) for the red lamps. The switches for the red lamps also control the individual lamps for the stand-by compass, No. 3 tank fuel gauge and the oxygen contents gauges.

(ii) Individual lamps for the machmeter and phase-failure indicator may also be provided, the lamp for the machmeter being controlled by a dimmer switch under the port front coaming and the lamp for the phase-failure indicator being controlled by a dimmer switch (89) on the voltmeter panel. The latter switch also controls the internal illumination of the pilot's radio compass bearing indicator.

(iii) The cockpit port wall, take-off panel and the port console are illuminated by four red flood lamps controlled by a single dimmer switch (20) on the cockpit port wall.

(c) Cabin

General illumination of the cabin is provided by a dome lamp with an integral switch and 2-pin socket, on the port wall at the navigator's station. Also two adjustable lamps with adjacent switches are installed, one above the navigator's instrument panel and one above the bomb control equipment.

(d) Inspection lamp

An inspection lamp, which can be plugged into the 2-pin socket of either dome lamp, is stowed in a bag on the cabin floor aft of the entrance door. An extension lead, for use with the lamp, is stowed in another bag adjacent to the lamp.

PART I—DESCRIPTIVE

(e) Emergency lighting station. Also two adjustable lamps

Emergency lighting of the main instrument panel is provided by two lamps controlled by an EMERGENCY LIGHTS switch (54) on the forward coaming.

(f) Cockpit anti-dazzle lighting

Two anti-dazzle lamps, one on each side of the flight instrument panel, are introduced by Mod. 2358. They are controlled by a BRIGHT-OFF-DIM switch on the cockpit forward coaming and by an OFF-BRIGHT switch on the navigator's instrument panel. Selecting BRIGHT on the navigator's switch overrides any prior selection on the pilot's switch.

63. External lighting

(a) All external lighting circuits are protected by a PILOT'S SERVICES circuit-breaker (at 3) on the rear face of the electrical control panel.

(b) All the external lighting control switches (39) are in line on the port console; from right to left they consist of the following:—

(i) The EXTERNAL LIGHTS MASTER switch; this must be ON before any of the external lights will function.

(ii) The downward identification lights STEADY switch.

(iii) The downward identification lights MORSE switch.

(iv) The landing lamp OFF-HIGH-LOW switch.

(v) The taxiing lamps switch.

(vi) The navigation lights switch; this also controls the navigation lights on the nose of the wing tip tanks.

(c) The taxiing lamps are fitted one in each wing tip, the landing lamp is in the port mainplane under-surface and the downward identification lights are in the fuselage under-surface just forward of the bomb bay.

OPERATIONAL EQUIPMENT AND CONTROLS—B.6

NOTE.—In the loft-bombing role the bombing installation and controls vary considerably from that installed for the normal bombing role. When an aircraft is equipped for loft bombing, details of the equipment should be obtained from the appropriate publications.

PART I—DESCRIPTIVE

64. **Bomb doors control and indicator**

- (a) The electrically-actuated bomb doors selector valve is controlled by a two-position OPEN—SHUT switch (11) on the port console. A magnetic indicator (10) forward of the control switch, normally black, shows white when the bomb doors are fully open.
- (b) To prevent inadvertent operation of the bomb doors on the ground a locking pin, stowed in a bag on the lower front face of the electrical control panel when not in use, is inserted in the control switch guard.

65. **Bomb doors emergency control**

- (a) Should the bomb doors selector valve fail to operate electrically it may be moved to the "open" position mechanically by pulling down the gated BOMB DOORS EMERGENCY CONTROL lever (16) on the cockpit port wall. However, as the bomb doors cannot then be closed again until serviced it must first be established that the fault is in the selector valve and not due to hydraulic failure (see para. 128).
- (b) If the failure is hydraulic and provided that fluid is available, the bomb doors may be opened and closed by means of the handpump and normal selections on the control switch. It should be noted however, that such action, by using the emergency reserve of fluid, may prejudice subsequent lowering of the undercarriage and wheel braking.

66. **Bomb control installation**

The bomb control equipment is on the starboard wall at the bomb-aimer's rear station and in the nose compartment at the bomb-aimer's nose station. The bomb release pushbutton, on a flexible lead in the nose compartment, is duplicated on top of the left-hand grip of the control column handwheel.

67. **Bomb jettisoning controls**

- (a) The pilot may jettison the bombs by means of a guarded EMERG BOMB JETTISON switch (12) on the port console. When this is switched ON, the normal bomb doors control circuit is by-passed, the bomb doors are opened

PART I—DESCRIPTIVE

and the bombs* jettisoned. Switching OFF the jettison switch will remake the normal control circuit and the bomb doors will close.

*NOTE.—25-lb. practice bombs carried on light series carriers cannot be jettisoned by means of the EMERG BOMB JETTISON switch.

- (b) Should the bomb doors fail to open when the jettison switch is set ON, by leaving the jettison switch ON and opening the bomb doors as at para. 65 (a) or (b) above, the bombs will be jettisoned when the bomb doors are fully open.

68. **Camera installation and controls**

An F24 camera is installed in a bay in the rear fuselage, aft of the bomb bay and the control unit is on the starboard wall at the bomb-aimer's station (see also para. 48 (a)).

OPERATIONAL EQUIPMENT AND CONTROLS—B.(I)6

69. **General**

In the interdicator role a gun pack is installed in the rear of the bomb bay and flares may be carried in the forward part of the bomb bay. In addition pylons are provided under the mainplanes for the carriage of bombs or rockets.

70. **Armament safety plug and circuit-breaker**

- (a) An armament safety plug is on the starboard side of the cabin at the bomb-aimer's station. Removing this plug breaks the circuits to all the armament services.
- (b) All the armament circuits are protected by a circuit-breaker (at 3) on the rear face of the electrical control panel.

71. **Flare doors normal and emergency operation**

The normal and emergency operation of the flare doors is exactly the same as that for the bomb doors as described in paras. 64 and 65.

72. Flare release controls and indicator

The flare release controls are on an armament panel on the starboard wall at the bomb-aimer's rear station. The flare release pushbutton on the armament panel is duplicated on the coaming above the main instrument panel. This enables either the bomb-aimer or the pilot to release the flares provided that the flares master switch on the armament panel is ON. A flares gone indicator is on the armament panel.

73. Flares jettisoning controls

Jettisoning the flares in an emergency is carried out in precisely the same manner as that for bomb jettisoning as described in para. 67. The only difference is that selecting the EMERG BOMB JETTISON switch ON, also releases any under-wing stores (see para. 75) which may be carried.

74. Underwing bombs and R.P. controls

The bombs or rockets are released by means of a pushbutton covered by a safety flap on the right-hand grip of the control column handwheel. Selection and fusing of these under-wing stores is carried out by means of five switches on the armament panel. These comprise:—

- (i) A bombs/R.P. selector switch.
- (ii) A pair of wing bomb ON/OFF selector switches.
- (iii) A wing bomb fusing switch.
- (iv) An R.P. selector switch which enables quarter, half or full load to be fired.

75. Emergency wing clearing

In addition to the EMERG BOMB JETTISON switch (see para. 73) underwing bombs or rockets may be jettisoned by means of the guarded WING CLEARING switch (36) on the port console. This does not jettison any stores in the flare bay.

76. Guns and firing control

Firing of the four 20 m/m. Hispano guns is controlled by a folding gun trigger on the right-hand grip of the control column handwheel. The trigger is released by raising a

safety catch on top of the grip. The guns cannot be fired with the nosewheel down, the flare doors open or the armament safety plug out. (See also para. 86 (a).)

77. Gunsight

A Mk. 3N reflector gunsight is fitted on the coaming above the main instrument panel. The master switch is on the gunsight.

78. Camera installation and controls

- (a) In addition to the F24 camera installation and controls as described in para. 68, a G45 camera is installed in the leading edge of the starboard wing. Provided that the camera master switch is on, it is operated automatically whenever the guns are fired: it may also be operated independently by a pushbutton on the control column handwheel right-hand grip.
- (b) The camera master switch and aperture switch are on the armament panel.

EMERGENCY EQUIPMENT

79. Canopy and hatch jettisoning and control column snatch unit

- (a) A JETTISON MASTER switch on the take-off panel must be ON before the canopy, control column snatch unit or cabin roof hatch jettisoning controls are operative.
- (b) A guarded CANOPY JETTISON MASTER SWITCH (31) on the port console controls the electrical circuit to the canopy explosive retaining bolts. When switched ON, it fires the detonators thus allowing the canopy to be blown off. It does not operate the control column snatch unit.
- (c) A lever on the port console, shielded by a flap (40) marked DANGER—CONTROL COLUMN RELEASE, controls the control column snatch unit. Pulling the lever upwards fires an explosive collar which severs the elevator control rod and, in turn, releases the spring in the snatch unit which pulls the control column forward against the instrument panel thus ensuring adequate clearance for the pilot on

PART I—DESCRIPTIVE

ejection. Longitudinal control can then only be effected by means of the tail-trim switch.

NOTE.—In flight, accidental release of the snatch unit spring (without operating the lever and severing the elevator control rod) will have little noticeable effect. It will be indicated by the need for about half a degree of nose-up trim and an increased pull force necessary to unstick on take-off.

A.L.1
Page 42
Para. 79
(d)

- (d) A guarded JETTISON switch on a panel marked DANGER-DETONATORS, HATCH JETTISON, located on the cabin wall at each rear crew station, control the electrical circuit to the hatch explosive retaining bolts. Switching on either switch, fires the detonators thus allowing the hatch to be blown off.

NOTE.—Mod. 2633 or 2634 introduces a cabin frangible roof hatch which, when fitted, will permit the navigator and bomb aimer to eject through it. The hatch introduced by Mod. 2634 incorporates provision for a periscopic sextant. However, until the ejection seats are fully modified (see NOTE to para. 80 (a)), ejection through these hatches is only to be attempted in extreme emergency.

- (e) The circuits operating these services are connected through the JETTISON MASTER switch direct to the battery bus-bar and also to the separate emergency battery (see para. 25 (a)). Therefore, provided that the master switch is on, the circuits will function with the battery isolating switch OFF, the inertia crash switches tripped or even if the aircraft battery has become damaged or disconnected.

80. Ejection seat—Mk. 1C

WARNING.—To prevent accidental operation of the firing handle a fabric safety strap attached to the drogue container is passed through the blind handle and secured by a safety pin to which is attached a metal disc. The pilot must ensure that each safety pin is removed and stowed in the stowage provided on the starboard side of the drogue containers, before flight and replaced before leaving the cockpit. All personnel, on entering the cockpit, must ensure that the firing handles are locked.

PART I—DESCRIPTIVE

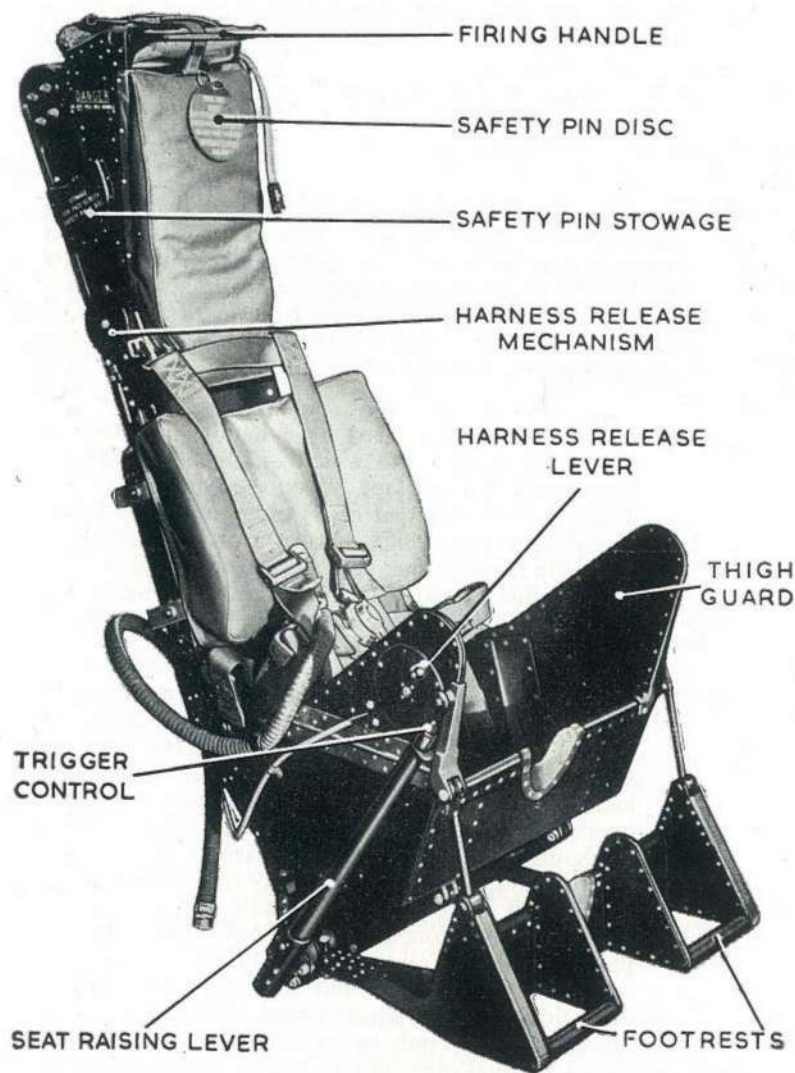

Ejection seat—Mk. 1C

PART I—DESCRIPTIVE

- (a) The ejection seat incorporates a headrest, footrests or leg restraining harness, and two thigh guards. The right thigh guard can be folded down to make access easier by releasing the clamp at the forward edge. Adjustment for height is effected by a lever, incorporating a thumb-operated spring-loaded catch, on the starboard side of the seat. At the rear of the seat is the ejection gun and on the port side the drogue gun.
- NOTE.—With ejection seat (E.S.) Mod. 447 (80 f.p.s. gun) embodied, the Mk. 1c seats so modified become ejection seats Mk. 1CN. With further E.S. Mods. 544 (leg restraint), 545 (strengthened thigh guards) and 577 (canopy breakers), plus either Mod. 2633 or 2634 (frangible roof hatch) embodied, the navigator and bomb-aimer may eject through the cabin roof hatch.
- (b) The Z-type harness lock may be released by a spring-loaded lever on the starboard thigh guard, to allow the wearer to lean forward. When the lever is released the harness is locked by a ratchet mechanism from going further forward; as the wearer leans back, however, the harness is locked in any position, and to lean forward again, he must operate the spring-loaded lever.
- (c) (i) The ejection gun is fired by a handle immediately above the headrest, to which is attached a flexible blind to protect the face. When the handle is pulled down to the full extent of its travel it fires the gun. The drogue gun, which releases a drogue parachute stowed in the container behind the headrest, is fired by a static line attached to the aircraft and does not operate until the seat is well clear. The drogue parachute slows the seat down and stabilises it.
- (ii) An automatic harness release operates in conjunction with a barometric parachute release; no provision is made for forcibly separating the occupant from the seat, as in fully automatic seats, and the seat must be kicked away after the automatic harness release has operated. The ejection of the seat starts a delay mechanism which operates the harness release after $2 \pm \frac{1}{2}$ seconds. The barometric control is then set to operate the parachute rip cord at a height of 13,000 feet. If the ejection height is below 13,000 feet the parachute will be released $2\frac{1}{2}$ to $4\frac{1}{2}$ seconds after the separation of the seat and the occupant. Manual operation of the harness is normal, though the harness quick-release can only be operated one way, i.e. to the left. A manual over-ride for operating the parachute is also provided, allowing instant operation of the parachute.

PART I—DESCRIPTIVE

- (d) Mod. parachute M.114 introduces a disconnection of the static line from the barometric release, to permit evacuation without ejection. To determine whether the parachute is set for manual or automatic operation the following checks, on the bayonet cap of the barometric release, are necessary.
- (i) *Cap in place.* This is proof that the parachute will function automatically and it is unnecessary to carry out any further tests.
- (ii) *Cap removed.* If the spring-loaded brass key has not sprung inward the cap can be replaced which is proof that the parachute will function automatically.
- (iii) *Cap removed.* If the spring-loaded brass key has sprung inward it is impossible to replace the cap. The parachute is set for manual operation only. To reset it to automatic it will be necessary to reset the static line disconnection and to repack the parachute.

81. Fire extinguishers

- (a) For details of engine fire-extinguishing equipment see para. 16.
- (b) A fire-extinguisher bottle is located on the rear face of the bomb bay aft bulkhead. It is discharged into the fuselage fuel tank and bomb/flare bay if the inertia crash switches (see para. 26) are tripped. This is the only method of operation for this extinguisher and only when it is discharged will the TANK FIRE warning light (61), on the miscellaneous instrument panel, come on.
- (c) A hand operated fire-extinguisher bottle is stowed on the cabin starboard wall just aft of the entrance door.

82. Signal pistol

- (a) There is a pressure-tight mounting for a signal pistol in the cabin roof hatch. The pistol can be loaded and fired whilst in its mounting with the cabin pressurised or otherwise but it can only be removed from its mounting for use as a hand pistol with the cabin unpressurised.
- (b) Signal cartridges are stowed on the cabin roof hatch.

NOTE.—When the pistol is in its mounting but unloaded, a loud wailing noise may be heard at around 200 knots; the noise will stop if the pistol is loaded or broken.

PART I—DESCRIPTIVE

83. Miscellaneous emergency equipment

(a) The following equipment is stowed on the cabin starboard wall just aft of the entrance door:—

- A crash axe
- A pair of asbestos gloves
- A first-aid kit

A.L.1
Page 46
Para. 83
(b), (c)

(b) Five pressure cabin leak stoppers may be provided in suitable stowages at the navigator's station.

(c) *Survival pack stowages*

Mod. 2186 introduces three survival pack stowage crates in the rear of the fuselage, access to which is through the camera hatch.

A.P.4326F—P.N.
Pilot's Notes

PART II
LIMITATIONS

84. Engine limitations—Avon Mk. 109

| Power rating | Time limit | R.p.m. | J.p.t. °C. |
|---|--------------|-----------|------------|
| Max. take-off and operational necessity | 10 mins. | 7,950±50 | 680 |
| Max. intermediate | 30 mins. | 7,750 | 620 |
| Max. continuous | Unrestricted | 7,500 | 575 |
| Idling on the ground | Unrestricted | 2,750±100 | 530 |

Oil pressures:

Minimum at 7,500 r.p.m. and above .. 15 lb./sq. in.
Normal at 7,500 r.p.m. 20 lb./sq. in.

NOTE.—1. At low air temperatures the engines may underspeed to as low as 7,800 r.p.m. at full throttle, but they will still maintain maximum thrust.

2. The ground r.p.m. will vary with a change in fuel density from that at which the engine settings were made. A higher density will cause a drop in r.p.m. and a lower density a rise. Every 0.01 change in density will cause a corresponding difference of 50 in the ground r.p.m.

85. Flying limitations

(a) The aircraft is designed as a light bomber and is cleared for normal bombing, loft bombing and, for the B.(I)6 only, interdiction. Intentional spinning and aerobatics, other than the loft bombing manœuvre, are prohibited.

NOTE.—Recovery from the loft manœuvre under instrument flight conditions is prohibited unless a Mk. 4C artificial horizon is fitted and Mod. 2515 is embodied.

This file was downloaded
from the RTFM Library.

Link: www.scottbouch.com/rtfm

Please see site for usage terms,
and more aircraft documents.

