

MISCELLANEOUS
ATTACHMENT DETAILS

Ref. No.	Part No.	Description						No. off	Matl. Spec.	Cl. of Equip. M.R. L.M.	Plate No.
		1	2	3	4	5	6				
	E.A1.00.21	WING TO FUSELAGE, ATTACHMENT DETAILS, PORT (PRE-MOD. 1018)						—	—	—	
		Spares for:—									
2089	E.A3.20.153	BLOCK , sealing, wing to fuselage joint						1	Linatex Rubber	C	MA.1
2090	E.A1.20.2897	BLOCK , sealing, wing to fuselage joint						1	Linatex Rubber	C	MA.1
384	E.A1.20.2899	BLOCK , sealing, wing to fuselage joint						1	Linatex Rubber	C	MA.1
387	E.A1.20.1101	BOLT , main pick-up, wing to fuselage attachment						2	DTD.473	C	MA.1
385	E.A1.20.2277	BOLT , special, wing to fuselage attachment						2	DTD.473	C	MA.1
28D/9140645	A25/10C	BOLT , 2 BA, hex. head, 1"45 long						1	—	C	MA.1
28D/1011318	A25/10N	BOLT , 1/2" BSF, hex. head, 1"8 long						1	—	C	MA.1
28D/12292	AGS.571/906	BOLT , shear, attachment, main spar to fuselage at frame 21						7	—	C	MA.1
	E.A1.11.129	COLLAR , special, rear spar to fuselage						1	DTD.126A	—	
2091	E.A3.20.573	GUSSET , top, main spar, closing panel						1	—	C	MA.1
2092	E.A3.20.574	GUSSET , top, main spar, closing panel						1	—	C	MA.1
2093	E.A3.20.575	GUSSET , bottom, main spar, closing panel						1	—	C	MA.1
2094	E.A3.20.576	GUSSET , bottom, main spar, closing panel						1	—	C	MA.1
28M/13259	A27/NS	NUT , 1/2" BSF, slotted						1	—	C	MA.1
28M/13590	A27/SS	NUT , 3/4" BSF, slotted						2	—	C	MA.1
28M/9153386	A27/WS	NUT , 1" BSF, slotted						2	—	C	MA.1
28M/7748	AGS.572/J	NUT , 7/8" BSF, thin, slotted						7	—	C	MA.1
28M/10288	AGS.2001/C/J	NUT , stiff, 2 BA						72	—	C	MA.1
28M/10388	AGS.2002/C/I	NUT , stiff, 2 BA						1	—	C	MA.1
386	E.A1.20.2275	PAD , special, wing attachment bolt						2	S.11	C	MA.1
	E.A1.11.127	PIN , special, rear spar to fuselage						1	S.11	—	
28P/19234	SP.90/E8	PIN , split, 3/8" dia. x 1" long						7	S.11	C	MA.1
28P/19235	SP.90/E10	PIN , split, 3/8" dia. x 1 1/4" long						1	—	C	MA.1
28P/20111	SP.90/H16	PIN , split, 3/8" dia. x 2" long						2	—	C	MA.1
28P/20112	SP.90/K20	PIN , split, 3/8" dia. x 2 1/2" long						2	—	C	MA.1
1025	EEAS.1/1C	SCREW , 2 BA, c'sk. head						28	—	C	MA.1
1026	EEAS.1/1 1/2 C	SCREW , 2 BA, c'sk. head						407	—	C	MA.1
1027	EEAS.1/2 1/2 C	SCREW , 2 BA, c'sk. head						23	—	C	MA.1
1029	EEAS.1/4C	SCREW , 2 BA, c'sk. head						44	—	C	MA.1
1425	E.A3.20.689	STRIP , closing, upper, aft of spar (Supplied undrilled and with trim allowance)						1	—	C	MA.2
1427	E.A3.20.691	STRIP , closing, lower, aft of spar (Supplied undrilled and with trim allowance)									MA.2
	E.A1.11.131	WASHER , distance, rear spar to fuselage						1	L.40	—	
2095	E.A1.20.1335	WASHER , special, main pick-up bolt						2	DTD.390	C	MA.1
2096	EEAS.27/16GU	WASHER , 14 SWG						72	DTD.124	C	MA.1
28W/3089	AGS.163/C	WASHER , 2 BA, spring						36	—	C	MA.1
28W/9419491	SP.16N	WASHER , 1/2" BSF, plain						1	—	C	MA.1
28W/9419480	SP.15/P	WASHER , 3/8" BSF, plain						7	—	C	MA.1

**MISCELLANEOUS
ATTACHMENT DETAILS**

Ref. No.	Part No.	Description	No. off	Matl. Spec.	Cl. of Equip.		Plate No.
					M.R.	L.M.	
	E.B6.00.21	WING TO FUSELAGE, ATTACHMENT DETAILS, PORT (MOD. 1018) Spares for this assembly are identical with those for assembly Part No. E.A1.00.21, on page 779 except for the following deletions and additions:— Delete:—	—	—	—		
2092	E.A3.20.574	GUSSET , top, main spar, closing panel	1	—	C		MA.1
2094	E.A3.20.576	GUSSET , bottom, main spar, closing panel Add:—	1	—	C		MA.1
1468	EEAS.1/2C	SCREW , 2 BA, c'sk. head	14	—	C		
1028	EEAS.1/3C	SCREW , 2 BA, c'sk. head	24	—	C		MA.1
1565	EEAS.1/3½C	SCREW , 2 BA, c'sk. head	32	—	C		MA.1
28W/9419482	SP.15/S	WASHER , thin	1	—	C		MA.1
28W/1009699	SP.55/C	WASHER , spring	38	—	C		
	E.A1.00.22	WING TO FUSELAGE, ATTACHMENT DETAILS, STARBOARD (PRE-MOD. 1018) Spares for this assembly are identical with those for assembly Part No. E.A1.00.21, on page 779, except for the following deletions and additions:— Delete:—	—	—	—		
1425	E.A3.20.689	STRIP , closing, upper, aft of spar (Supplied undrilled and with trim allowance)	1	—	C		MA.2
1427	E.A3.20.691	STRIP , closing, lower, aft of spar (Supplied undrilled and with trim allowance) Add:—	1	—	C		MA.2
1426	E.A3.20.690	STRIP , closing, upper, aft of spar (Supplied undrilled and with trim allowance)	1	—	C		MA.2
1428	E.A3.20.692	STRIP , closing, lower, aft of spar (Supplied undrilled and with trim allowance)	1	—	C		MA.2
	E.6B.00.22	WING TO FUSELAGE, ATTACHMENT DETAILS, STARBOARD (MOD. 1018) Spares for this assembly are identical with those for assembly Part No. E.A1.00.21, on page 779, except for the following deletions and additions:— Delete:—	—	—	—		
2091	E.A3.20.573	GUSSET , top, main spar, closing panel	1	—	C		MA.1
2093	E.A3.20.575	GUSSET , bottom, main spar, closing panel	1	—	C		MA.1
1425	E.A3.20.689	STRIP , closing, upper, aft of spar (Supplied undrilled and with trim allowance)	1	—	C		MA.2
1427	E.A3.20.691	STRIP , closing, lower, aft of spar (Supplied undrilled and with trim allowance) Add:—	1	—	C		MA.2
1426	E.A3.20.690	STRIP , closing, upper, aft of spar (Supplied undrilled and with trim allowance)	1	—	C		MA.2
1428	E.A3.20.692	STRIP , closing, lower, aft of spar (Supplied undrilled and with trim allowance)	1	—	C		MA.2

MISCELLANEOUS ATTACHMENT DETAILS

Ref. No.	Part No.	Description	No. off	Matl. Spec.	Cl. of Equip.	Plate No.
					M.R. L.M.	
	E.A1.00.23	FRONT FUSELAGE TO CENTRE FUSELAGE ATTACHMENT DETAILS Consisting of:—	—	—	—	
392	E.A1.10.1207	BOLT , special attachment	111	S.11	C	MA.2
393	E.A1.10.1209	BOLT , special attachment (Pre-Mod. 4066)	54	S.11	C	MA.2
	E.B6.10.1505	BOLT , special, attachment (Mod. 4066)	56	S.98	—	
28D/9436920	A25/1C	BOLT , 2 BA, hex. head, "55 long	18	—	C	MA.2
28D/9133011	A25/2C	BOLT , 2 BA, hex. head "65 long	13	—	C	MA.2
28D/9706895	A25/15N	BOLT , 1/4" BSF, hex. head, 2"3 long	4	—	C	MA.2
33H/56	†	CEMENT , Bostik	QR	—	C	
28M/10294	AGS.2001/N/1	NUT , stiff, 1/2" BSF	4	—	C	MA.2
28W/9703147	AGS.163/D	WASHER , 1/4" BSF, Spring	111	—	C	MA.2
28W/3091	AGS.163/E	WASHER , 1/8" BSF, spring	54	—	C	MA.2
28W/9419475	SP.15/C	WASHER , 2 BA, plain	31	—	C	MA.2
5484	E.A1.10.2713	WASHER , special	4	—	C	
	E.B6.00.25	CENTRE FUSELAGE TO REAR FUSELAGE, ATTACHMENT DETAILS Consisting of:—	—	—	—	
28D/1008145	A25/6E	BOLT , 1/4" BSF, hex. head, 1"1 long	48	—	C	
28D/1011242	A25/7E	BOLT , 1/4" BSF, hex. head, 1"2 long	8	—	C	
28D/1011245	A25/10E	BOLT , 1/4" BSF, hex. head, 1"5 long	6	—	C	
28D/1011247	A25/13E	BOLT , 1/4" BSF, hex. head, 1"8 long	24	—	C	
28D/7002427	A25/6G	BOLT , 1/8" BSF, hex. head, 1"15 long	16	—	C	
28D/1011257	A25/7G	BOLT , 1/8" BSF, hex. head, 1"25 long	8	—	C	
28D/1006942	A25/13G	BOLT , 1/8" BSF, hex. head, 1"85 long	30	—	C	
28D/1011261	A25/15G	BOLT , 1/8" BSF, hex. head, 2"5 long	12	—	C	
28D/9706828	A25/16N	BOLT , 1/4" BSF, hex. head, 2"4 long	2	—	C	
28D/1011320	A25/18N	BOLT , 1/4" BSF, hex. head, 2"6 long	2	—	C	
33H/72	CS.2558	CEMENT	QR	—	C	
28M/10290	AGS.1001/E/1	NUT , stiff, 1/4" BSF	90	—	C	
28M/10291	AGS.2001/G/1	NUT , stiff, 1/8" BSF	66	—	C	
28M/10294	AGS.2002/N/1	NUT , stiff, 1/2" BSF	4	—	C	
28W/9419405	SP.15/E	WASHER , 1/4" BSF, plain	58	—	C	
28W/9419476	SP.15/G	WASHER , 1/8" BSF, plain	16	—	C	
5484	E.A1.10.2713	WASHER , special	4	—	C	
	E.B6.00.53	TAIL PLANE TO REAR FUSELAGE, ATTACHMENT DETAILS Consisting of:—	—	—	—	
2751	E.A3.30.75	BOLT , special pivot, tail plane attachment, forward hinge point	2	S.97	C	MA.2
309	E.A1.12.451	BOLT , special, tail plane, actuator anchor	1	S.65	C	MA.2
310	E.A1.30.341	NUT , special, tail plane attachment, forward hinge point	2	L.40	C	MA.2
311	E.A1.12.453	NUT , special, slotted, tail plane actuator anchor	1	M.S.	C	MA.2
28N/9156370	SP.21	NIPPLE , lubricating	2	—	C	MA.2
28P/19235	SP.90/E10	PIN , split, 3/32" x 1 1/4"	3	—	C	MA.2
312	E.A1.12.455	WASHER , special, tail plane actuator anchor	2	L.75	C	MA.2

**MISCELLANEOUS
ATTACHMENT DETAILS**

Ref. No.	Part No	Description	No. off	Matl Spec.	Cl. of Equip.		Plate No.
					M.R.	L.M.	
	E.A1.00.55	FIN TO FUSELAGE, ATTACHMENT DETAILS ...					
		Consisting of:—					
313	E.A1.32.75	BOLT , special, fin attachment, port	1	DTD.473	C		MA.3
314	E.A1.32.77	BOLT , special, fin attachment, starboard	1	DTD.473	C		MA.3
28D/9436920	A25/1C	BOLT , 2 BA, hex. head, "55 long	10	—	C		MA.3
28D/9140644	A25/9C	BOLT , 2 BA, hex. head, 1"35 long	6	—	C		MA.3
28D/1007975	AS.1242/1C	BOLT , 2 BA, c'sk. head, "5 long	18	—	C		MA.3
28D/1214091	AS.1242/2C	BOLT , 2 BA, c'sk. head, "6 long	36	—	C		MA.3
1029	EEAS.1/4C	SCREW , 2 BA, c'sk. head	58	—	C		MA.3
1030	EEAS.1/5C	SCREW , 2 BA, c'sk. head	20	—	C		MA.3
	E.A1.00.57	RUDDER TO FIN AND FUSELAGE, ATTACHMENT DETAILS					
		Consisting of:—					
4730	E.A1.32.203	BOLT , special attachment, rudder to fin top hinge ...	2	S.11	C/MR		MA.3
4731	E.A1.32.205	BOLT , special attachment, rudder to fin top hinge ...	2	S.11	C/MR		MA.3
28M/13590	A27/SS	NUT , 3/4" BSF, slotted	1	—	C		MA.3
28P/9527619	SP.90/C7	PIN , split, 1/8" x 1"	1	—	C		MA.3
3667	E.A3.33.219	WASHER , special sealing	1	L.40	C		MA.3
	E.A1.00.59	REAR FAIRING TO FUSELAGE, ATTACHMENT DETAILS					
		Consisting of:—					
28D/1008151	A25/4E	BOLT , 1/2" BSF, hex. head, "85 long	2	—	C		MA.3
28M/1011467	A27/ES	NUT , 1/2" BSF, slotted	2	—	C		MA.3
28M/10290	AGS.2001/E/1	NUT , 1/2" BSF, stiff	4	—	C		MA.3
28P/9527619	SP.90/C7	PIN , split, 1/8" x 1"	2	—	C		MA.3
1028	EEAS.1/3C	SCREW , 2 BA, c'sk. head	4	—	C		MA.3
28W/9419487	SP.16/E	WASHER , 1/4" BSF, plain	2	—	C		MA.3
	E.A1.00.63	CONTROLS TO RUDDER AND ELEVATOR, ATTACHMENT DETAILS					
		Consisting of:—					
67	EEAS.13/1	BOLT , special connecting, control rod to rudder ...	2	—	C		MA.3
68	EEAS.14	BUSH , bearing, connecting rod	2	—	C		MA.3
3569	EEAS.63/E	NUT , slotted, control tube connecting bolt ...	2	S.96	C		MA.3
3570	EEAS.127	PIECE , distance, control tube connection ...	2	S.96	C		MA.3
28P/9427619	SP.90/C7	PIN , split, 1/8" x 1"	2	—	C		MA.3
	E.A1.00.81	DROP TANK TO WING, ATTACHMENT DETAILS					
		(See page 573)					
	E.A1.00.82	DROP TANK TO WING, ATTACHMENT DETAILS					
		(See page 585)					

Pages ~~785~~ to 794 not issued

783

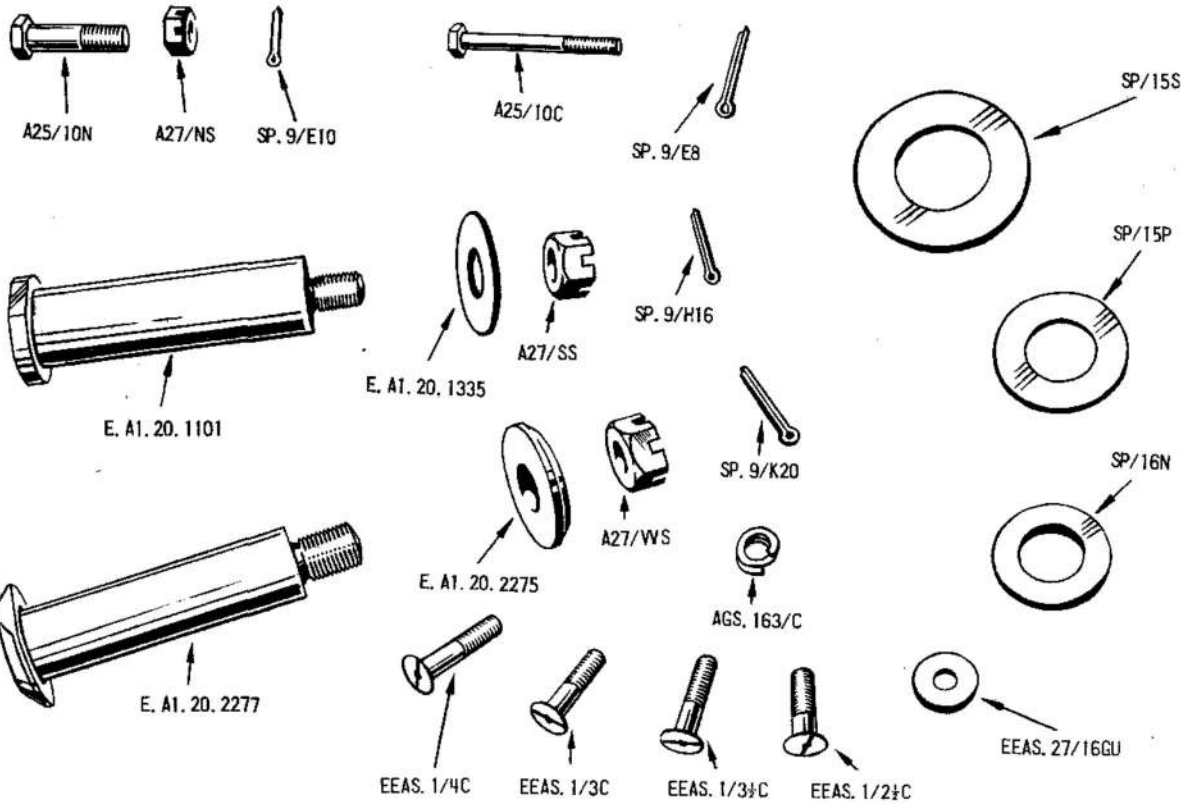
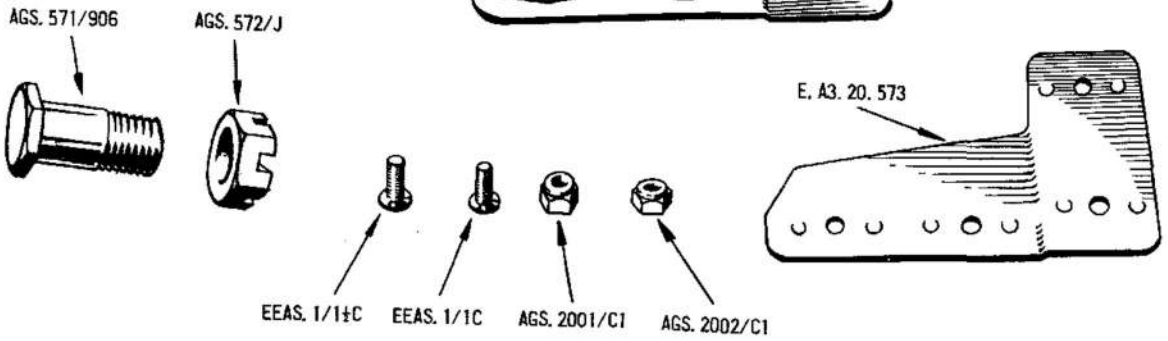
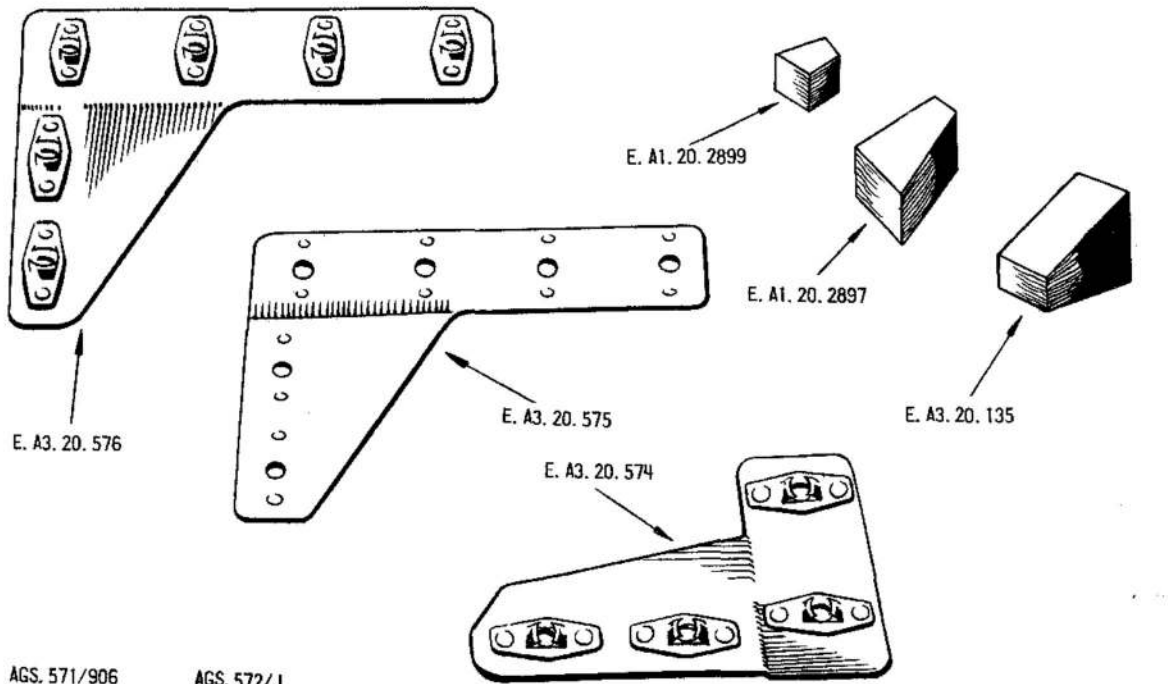

MISCELLANEOUS ATTACHMENTS

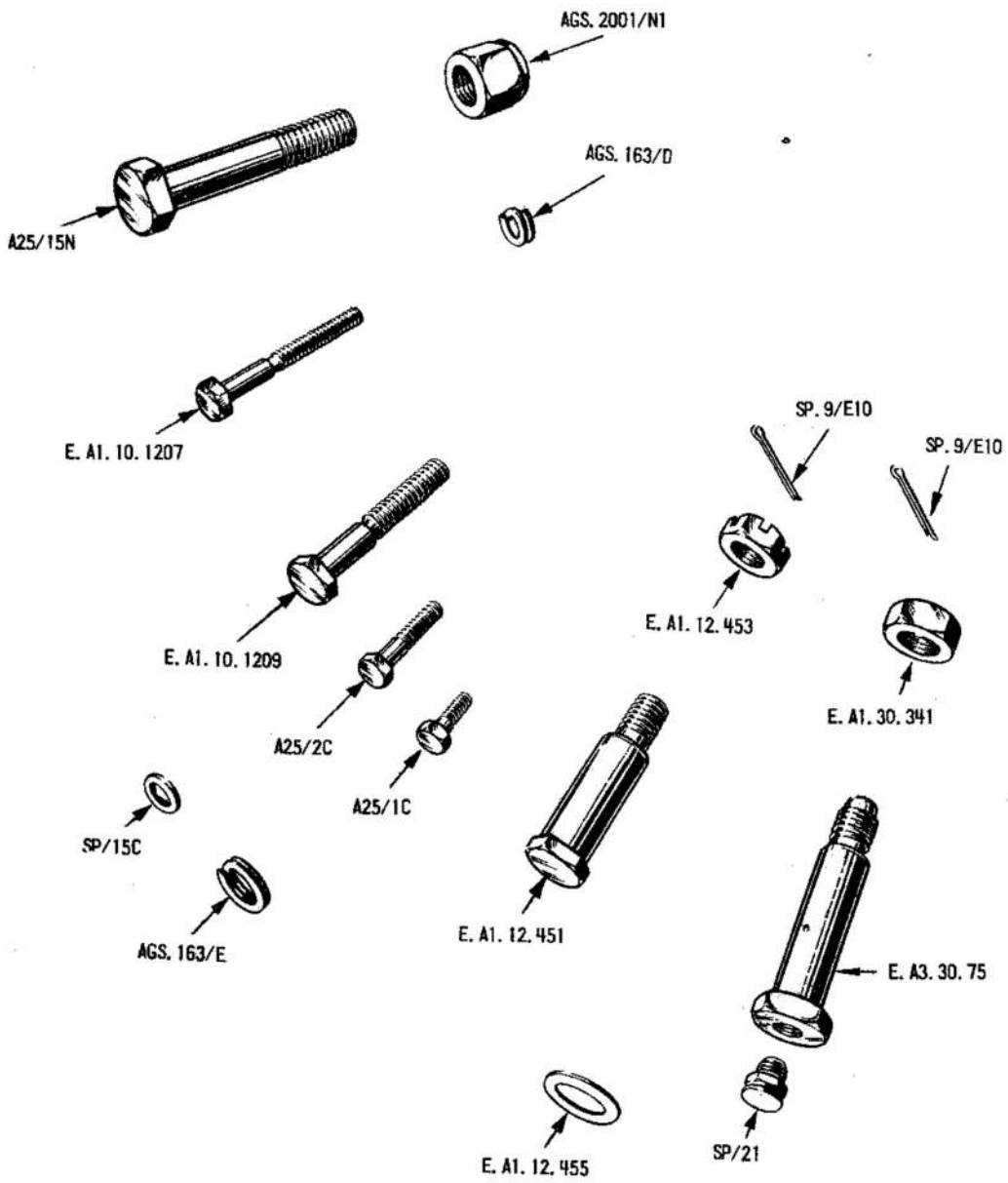

E. A3. 20. 691
E. A3. 20. 692

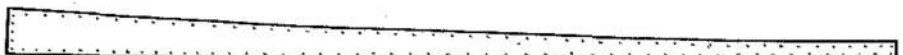

E. A3. 20. 689
E. A3. 20. 690

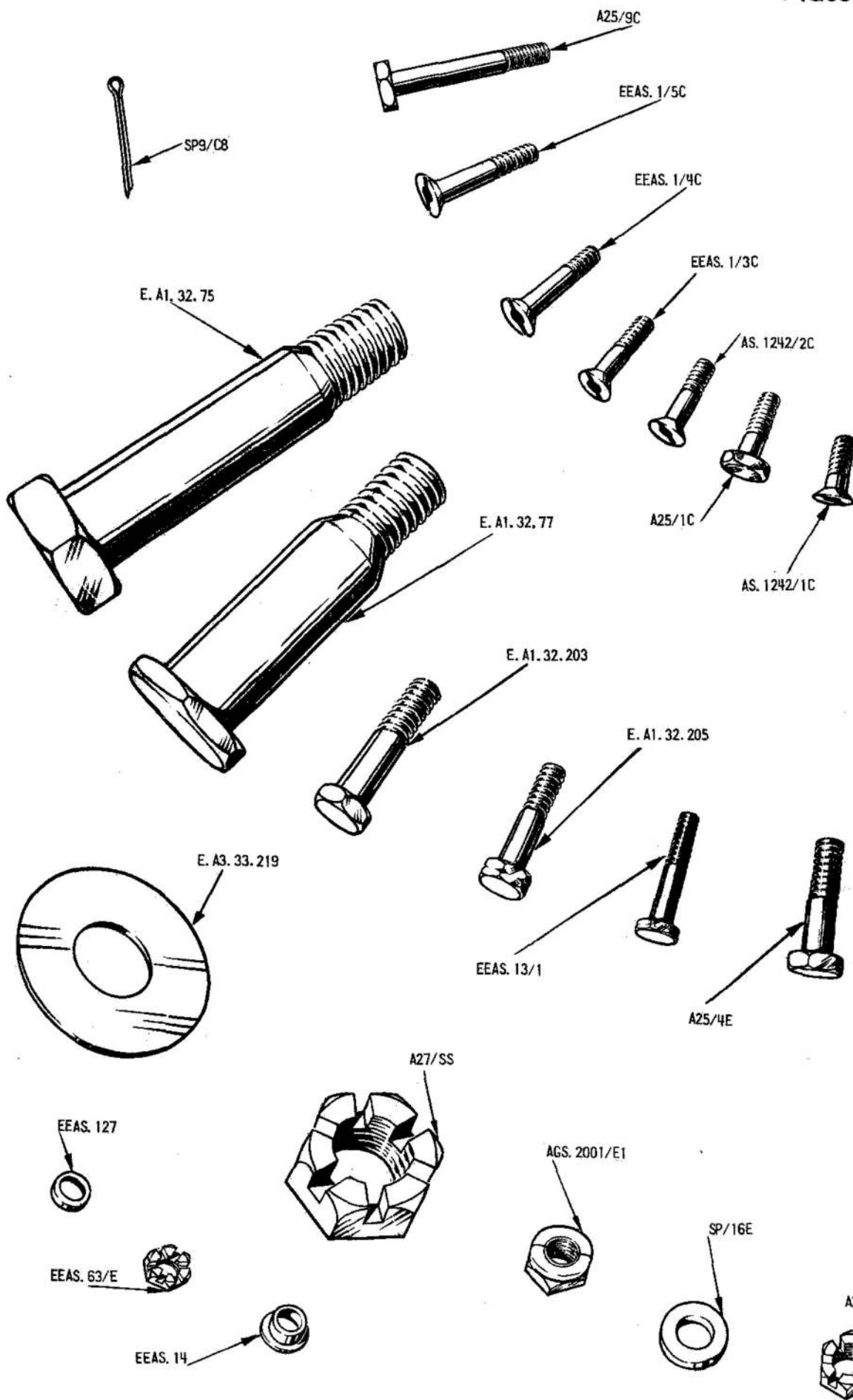

This file was downloaded
from the RTFM Library.

Link: www.scottbouch.com/rtfm

Please see site for usage terms,
and more aircraft documents.



LIGHTNING MK. 1
COVER PITOT HEAD
EB2-88-511