

**TAIL UNIT  
RUDDER C/W TAB**

Ref. No.	Part No.	Description	No. off	Matl. Spec.	Cl. of Equip.		Plate No.
					M.R.	L.M.	
		1 2 3 4 5 6					
12139	E.A9.33.1	<b>RUDDER, C/W TAB, ASSEMBLY</b> ... .. Spares for:—	1	—	A		TU.1/8
9992	E.A1.33.489	<b>BOLT</b> , special, balance weight ... ..	4	—	C		
333	E.A1.31.63	<b>BOLT</b> , special, bearing tab bottom hinge ... ..	1	S.11	C		
328	E.A1.31.65	<b>BOLT</b> , special, tab control attachment ... ..	1	S.96	C		
329	E.A1.33.247	<b>BOLT</b> , special, trim tab actuator connecting ... ..	1	S.11	C		
4156	E.A1.33.287	<b>BOLT</b> , special, nose rib 2 and trailing edge, rib 2 attachment to spar	2	S.65	C		
1051	EEAS.13	<b>BOLT</b> , special, tab control rod connecting ... ..	1	S.11	C		
5876	E.A1.33.283	<b>BRACKET, TOP, HINGE MOUNTING, GROUP</b> ... .. Consisting of:—	1	—	B		TU.1/8
	E.A1.33.71	<b>BRACKET, HINGE, RUDDER, GROUP</b> ... .. Spares for:—	1	—	—		TU.1/8
	HOFFMANN						
2A/9500467	CA.3	<b>BALLRACE</b> ... ..	1	—	C		TU.1/8
1041	EEAS.3/J	<b>HOUSING</b> ... ..	1	—	C		TU.1/8
20452	EEAS.4/18J	<b>WASHER</b> , packing ... ..	2	—	C		
2100	E.A1.33.293	<b>BRACKET</b> , hinge mounting ... ..	1	DTD.683	C		TU.1/8
3668	E.A3.33.215	<b>CUP</b> , sealing ... ..	2	Rubber	C		TU.1/8
28M/5808571	A27/GS	<b>NUT</b> , 3/8" BSF ... ..	1	—	C		TU.1/8
330	E.A1.33.281	<b>PIN</b> , special, hinge ... ..	1	S.65	C		TU.1/8
28P/9527619	SP.90/C7	<b>PIN</b> , split ... ..	1	—	C		
3669	E.A3.33.213	<b>PLATE</b> , locking ... ..	1	DTD.124A	C		TU.1/8
28W/9419477	SP.15/J	<b>WASHER</b> ... ..	1	—	C		
68	EEAS.14	<b>BUSH</b> , for tab control rod special bolt ... ..	1	S.96	C		
2101	E.A1.33.297	<b>COWL</b> , rudder, tab control rod ... ..	1	L.59	C		TU.1/8
9994	E.A1.33.189	<b>HINGE, BOTTOM TAB AT RIB 1, GROUP</b> ... .. Consisting of:—	1	—	B		
	2A/9500463	<b>BALLRACE</b> ... ..	1	—	C		
28N/9144935	AGS.2030/24	<b>CIRCLIP</b> , internal, 3/8" dia. ... ..	1	—	C		
	E.A1.33.189A	<b>HOUSING</b> , ballrace ... ..	1	L.40	—		
	E.A9.33.7	<b>NOSE, RUDDER AND PIVOT POINT, GROUP</b> ... .. Spares for:—	1	—	—		
	E.A3.33.247	<b>ARM</b> , mass balance ... ..	1	—	—		
	RANSOME						
	MARLES						
2A/9500423	CA.1 1/2	<b>BEARING</b> , ballrace, main lower, tab operating gear	1	—	C		
331	E.A1.33.301	<b>BOLT</b> , special, rudder trim tab actuator ... ..	1	S.11	C		
9949	E.A1.33.125	<b>BRACKET, BOTTOM RUDDER HINGE, GROUP</b> ... .. Spares for:—	1	—	B		
18220	E.A3.33.217	<b>SHROUD</b> , sealing ... ..	1	—	C		
2733	E.A1.33.815	<b>SPIGOT</b> , rudder bottom bearing ... ..	1	S.11	C		TU.1/8
13097	E.A3.00.259	<b>GEAR, TAB OPERATING, GROUP (E.A1.33.215)</b> ... .. Spares for:—	1	—	B		TU.1/8
19745	E.A1.33.241	<b>BOLT</b> , special, lever attachment ... ..	3	—	C		
19742	E.A1.33.231	<b>BRACKET</b> , lever stop ... ..	1	—	C		
19739	E.A1.33.161	<b>LEVER</b> , assembly ... ..	1	—	C		
19731	E.A1.33.211	<b>STOP</b> , limit ... ..	1	—	C		
19753	E.A1.33.803	<b>TUBE, TORQUE, OUTER, ASSEMBLY</b> ... .. Spares for:—	1	—	—		✓
19751	E.A1.33.721	<b>LEVER</b> , assembly ... ..	1	—	B		

**TAIL UNIT  
RUDDER C/W TAB**

Ref. No.	Part No.	Description	No. off	Matl. Spec.	Cl. of Equip.	Plate No.
					M.R. L.M.	
2103	E.A1.33.177	<b>HOUSING, BEARING, FOR RUDDER OPERATING GEAR AT RIB 6, GROUP</b>	1	—	B	TU.1/8
19736	E.A1.33.123	Spares for:— <b>BEARING, housing</b> ... ..	1	L.40	MR	
2A/9500420	CA. ½	<b>BEARING, ballrace</b> ... ..	1	—	C	TU.1/8
28N/12456	AGS.2031/24	<b>CIRCLIP, external, 1½" dia.</b> ... ..	1	—	C	TU.1/8
28N/2001693	AGS.2030/48	<b>CIRCLIP, internal, 1½" dia.</b> ... ..	1	—	C	TU.1/8
19741	E.A1.33.179	<b>LEVER, tab control</b> ... ..	1	—	C/MR	
5495	E.A1.33.205	<b>PLATE, stop</b> ... ..	1	L.40	C/MR	TU.1/8
19743	E.A1.33.201	<b>RING</b> ... ..	1	L.64	C/MR	TU.1/8
19730	E.A1.33.203	<b>TUBE, distance</b> ... ..	1	T.4	C/MR	TU.1/8
6360	E.A1.33.383	<b>HOUSING, bearing, tab operating gear at rib 2</b>	1	L.40	C/MR	TU.1/8
9715	E.A1.33.445	<b>PANEL, access, lower, port</b> ... ..	1	—	C	
9716	E.A1.33.447	<b>PANEL, access, lower starboard</b> ... ..	1	—	C	
5402	E.A1.33.791	<b>PANEL, access, centre</b> ... ..	1	—	C	
9717	E.A1.33.425	<b>PLUG, sealing, rudder lifting point, assembly</b> ...	2	—	C	
6833	E.A1.33.57	<b>RIB, No. 1, leading edge, port (Pre-Mod. 4427)</b> ...	1	—	MR	
1438852	E.A9.33.75	<b>RIB, No. 1, leading edge, port (Mod. 4427)</b> ... (Supplied to Part No. E.A3.00.5265 for spares purposes)	1	—	MR	
6834	E.A1.33.58	<b>RIB, No. 1, leading edge, starboard (Pre-Mod. 4427)</b>	1	—	MR	
1438853	E.A9.33.76	<b>RIB, No. 1, leading edge, starboard (Mod. 4427)</b> ... (Supplied to Part No. E.A3.00.5266 for spares purposes)	1	—	MR	
1025	EEAS.1/1C	<b>SCREW, 2 BA</b> ... ..	26	S.11	C	
	E.A9.33.15	<b>SPAR, RUDDER, ASSEMBLY</b> ... ..	1	—	—	
26556	E.A1.33.463	Spares for:— <b>DIAPHRAGM, rudder spar</b> ... ..	1	—	MR	
6361	E.A1.33.503	<b>WASHER, saddle, tab operating gear, top nut locking bolt</b>	2	—	C	
1523	E.A1.33.779	<b>NUT, special, balance weight clamping</b> ... ..	1	MS	C	
9962	E.A3.33.133	<b>PAD, balance weight, assembly</b> ... ..	1	—	C/MR	
9957	E.A1.33.75	<b>RIB, trailing, No. 2, assembly</b> ... ..	1	—	C/MR	
9958	E.A1.33.77	<b>RIB, trailing, No. 3, assembly</b> ... ..	1	—	C/MR	
9960	E.A1.33.93	<b>RIB, TRAILING, NO. 6, ASSEMBLY</b> ... ..	1	—	MR	
18216	E.A1.33.187	Spares for:— <b>HINGE, tab, centre</b> ... ..	1	—	C	
28D/9133011	A25/2C	Attaching parts for E.A1.33.187:— <b>Bolt, 2 BA</b> ... ..	1	—	C	
28D/9133012	A25/3C	<b>Bolt, 2 BA</b> ... ..	2	—	C	
28M/9403520	A27/CP	<b>Nut, 2 BA</b> ... ..	3	—	C	
28W/9419475	SP.15/C	<b>Washer</b> ... ..	2	—	C	
10007	E.A3.33.271	<b>ROD, TAB CONTROL, GROUP</b> ... .. <i>E.A3-33-305</i>	1	—	B	TU.1/8
12026	E.A3.33.269	Spares for:— <b>BOLT, special, adjusting</b> ... ..	1	S.95	C	TU.1/8
28R/13507	CF.2	<b>END-ROD</b> ... ..	1	—	C	TU.1/8
3225	EEAS.131/1	<b>FORK-END, for control tube</b> ... ..	1	DTD.683	C	TU.1/8
1573	EEAS.37/13A	<b>NIPPLE, ½"</b> ... ..	10	—	C	TU.1/8
	E.A1.33.275	<b>SOCKET, screwed</b> ... ..	1	L.40	—	
	EEAS.38/1A	<b>SPOKE, 6 BA (Make from 28R/6123)</b> ... ..	5	—	—	
9983	E.A1.33.811	<b>SKIN, panel, upper, port</b> ... ..	1	—	C/MR	
9984	E.A1.33.812	<b>SKIN, panel, upper, starboard</b> ... ..	1	—	C/MR	
9995	E.A3.33.93	<b>SKIN, panel, lower, port</b> ... ..	1	—	C/MR	
9996	E.A3.33.94	<b>SKIN, panel, lower, starboard</b> ... ..	1	—	C/MR	
9912	E.A3.33.97	<b>SKIN, panel, intermediate, port</b> ... ..	1	—	C/MR	
9919	E.A3.33.98	<b>SKIN, panel, intermediate, starboard</b> ... ..	1	—	C/MR	

**TAIL UNIT  
RUDDER C/W TAB**

Ref. No.	Part No.	Description						No. off	Matl. Spec.	Cl. of Equip.		Plate No.
		1	2	3	4	5	6			M.R.	L.M.	
10005* 32176	E.A3.33.231	<b>SPOILER</b>	rudder trailing edge, port ... ..	...	...	...	1	—		C		
			(Supplied to Part No. E.A3.00.897 for spares purposes)									
10006* 32177	E.A3.33.232	<b>SPOILER</b>	rudder trailing edge, starboard ... ..	...	...	...	1	—		C		
			(Supplied to Part No. E.A3.00.898 for spares purposes)									
3368	E.A3.33.21	<b>TAB, RUDDER, TRIM, GROUP</b>	...	...	...	...	1	—		A	TU.1/8	
			Spares for:—									
4679	E.A3.31.53	<b>ARM</b>	balance support ... ..	...	...	...	6	L.40		C/MR	TU.1/8	
4160	E.A1.45.49	<b>BOLT</b>	special, balance weight retaining ... ..	...	...	...	8	S.1		C/MR		
19754	E.A3.33.23	<b>BRACKET</b>	rudder, tab actuator ... ..	...	...	...	1	—		C		
334	E.A1.31.61	<b>PIN</b>	hinge, bearing ... ..	...	...	...	2	S.11		C		
335	E.A1.33.249	<b>WASHER</b>	special thrust, at trim tab actuator con- necting bolt				2	L.40		C		
2104	EEAS.28/8GR	<b>WASHER</b>	special thrust, at tab control attachment				2	L.72		C		
9993	E.A1.33.491	<b>WASHER</b>	fillet, balance weight ... ..	...	...	...	4	—		C/MR		
7088	E.A1.33.481	<b>WASHER</b>	balance, balance weight ... ..	...	...	...	19	—		C/MR		
9991	E.A1.33.483	<b>WEIGHT</b>	balance ... ..	...	...	...	7	—		B/MR		
9953	E.A3.33.249	<b>WEIGHT</b>	balance ... ..	...	...	...	1	—		B/MR		
9963	E.A3.33.139	<b>WEIGHT</b>	balance ... ..	...	...	...	3	—		B/MR		

Ref. No.	Part No.							No. off	Matl. Spec.	Cl. of Equip.	Plate No.
		1	2	3	4	5	6			M.R. L.M.	

1725

~~1723~~ - 1744 (AL-18)

**Pages ~~1725~~ to 1744 not issued**

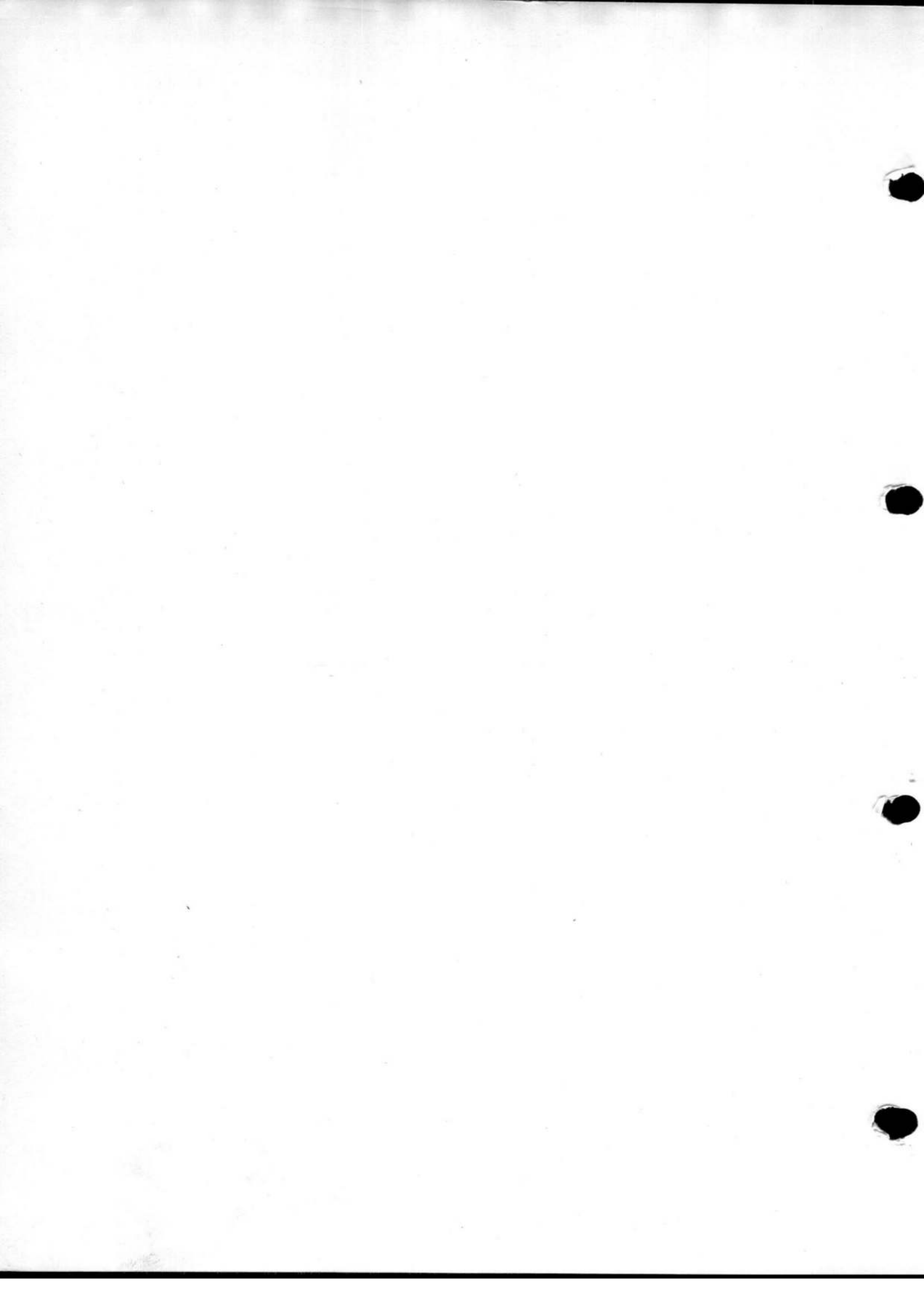

**TAIL UNIT  
RUDDER C/W TAB**

Ref. No.	Part No.	Description						off	Matl. Spec.	Cl. of Equip. M.R. L.M.	Plate No.
		1	2	3	4	5	6				
<b>SUMMARY OF STOCK ITEMS USED ON RUDDER C/W TAB, ASSEMBLY</b>											
28D/9133011	A25/2C	Bolt,	2	BA	...	...	...	...	...	C	
28D/9133012	A25/3C	Bolt,	2	BA	...	...	...	...	...	C	
28D/1200119	A25/4C	Bolt,	2	BA	...	...	...	...	...	C	
28D/1011030	A25/2E	Bolt,	3/4"	BSF	...	...	...	...	...	C	
28D/1011238	A25/3E	Bolt,	1/2"	BSF	...	...	...	...	...	C	
28D/1011240	A25/5E	Bolt,	3/4"	BSF	...	...	...	...	...	C	
28D/7002413	A25/14E	Bolt,	3/4"	BSF	...	...	...	...	...	C	
28D/12635	A25/24E	Bolt,	1/2"	BSF	...	...	...	...	...	C	
28D/9140203	AS.1246/3C	Bolt,	2	BA	...	...	...	...	...	C	
28D/1214388	AS.1246/46E	Bolt,	3/4"	BSF	...	...	...	...	...	C	
28D/1214389	AS.1246/56E	Bolt,	3/4"	BSF	...	...	...	...	...	C	
28D/1013284	AS.1248/2C	Bolt,	2	BA	...	...	...	...	...	C	
28M/9403520	A27/CP	Nut,	2	BA	...	...	...	...	...	C	
28M/5808573	A27/CS	Nut,	2	BA	...	...	...	...	...	C	
28M/1011467	A27/ES	Nut,	1/4"	BSF	...	...	...	...	...	C	
28M/1007403	A27/ET	Nut,	1/4"	BSF	...	...	...	...	...	C	
28M/1006939	A27/GP	Nut,	3/8"	BSF	...	...	...	...	...	C	
28M/13376	A29/EP	Nut,	1/4"	BSF	...	...	...	...	...	C	
28M/13717	A29/GP	Nut,	3/8"	BSF	...	...	...	...	...	C	
28M/13718	A29/GPL	Nut,	3/8"	BSF	...	...	...	...	...	C	
28M/10288	AGS.2001/C/1	Nut, stiff,	2	BA	...	...	...	...	...	C	
28M/10281	AGS.2001/C/3	Nut, stiff,	2	BA	...	...	...	...	...	C	
28M/10328	AGS.2002/C/1	Nut, stiff,	1	BA	...	...	...	...	...	C	
28M/8932	CD.1	Nut, stiff,	2	BA	...	...	...	...	...	C	
28P/9527619	SP.90/C7	Pin, split	...	...	...	...	...	...	...	C	
28W/9419475	SP.15/C	Washer	...	...	...	...	...	...	...	C	
28W/9419405	SP.15/E	Washer	...	...	...	...	...	...	...	C	
28W/9419476	SP.15/G	Washer	...	...	...	...	...	...	...	C	
28W/9419404	SP.16/C	Washer	...	...	...	...	...	...	...	C	
28W/9419487	SP.16/E	Washer	...	...	...	...	...	...	...	C	

Ref. No.	Part No.	1	2	3	4	5	6	Description	off	Matl. Spec.	Cl. of Equip. M.R. L.M.	Plate No.

**TAIL UNIT  
TAILPLANE AND ELEVATORS**

Ref. No.	Part No.	Description	No. off	Matl. Spec.	Cl. of Equip.	Plate No.
					M.R. L.M.	
	E.A9.00.21	<b>TAILPLANE AND ELEVATORS, ASSEMBLY (MOD. 2182)</b>	—	—	—	
		Spares for:—				
3385	E.A3.31.45	BOLT, special, in port elevator operating lever ...	1	S.95	C	
67	EEAS.13/1	BOLT, special, 1/4" BSF ...	1	S.11	C	
1590	E.A1.30.335	BUFFER, rubber stop, elevator control ...	2	Shore 45	C	
3386	E.A3.31.47	BUSH, serrated, for special bolt, port elevator operating lever	1	S.95	C	
13241	E.A9.31.1	<b>ELEVATOR, C/W TAB, PORT, GROUP (MOD. 2182)</b>	1	—	A	TU.2
		Spares for:—				
	E.A1.31.709	<b>BALANCE, MASS, ELEVATOR, PORT, GROUP</b>	1	—	—	
		Consisting of:—				
	E.A1.31.711	ARM, balance weight ...	1	G.E.C.	—	
				Heavy Metal		
21988	E.A1.31.713	ARM, balance weight ...	1	S.95	MR	
21692	E.A1.31.133	BOLT, special, make-up balance weight ...	2	MS	MR	
20687	E.A1.31.705	PIN, special, locking balance weight to arm ...	1	S.95	MR	
19724	E.A1.31.707	PLUG, screwed end fitting ...	1	S.95	C/MR	
43227	E.A1.31.129	WEIGHT, balance make-up ...	1	G.E.C.	MR	
				Heavy Metal		
30A/9140209	†	WIRE, locking, 20 SWG ...	QR	—	C	
	SKEFKO					
2A/9500463	CBA.2	BEARING, ballrace, elevator tab ...	1	—	C	
	SKEFKO					
2A/9500419	T.T.S.8½	BEARING, ballrace tab control lever at tab torque mounting	1	—	C	
333	E.A1.31.63	BOLT, special, bearing tab hinge ...	1	S.11	C	
328	E.A1.31.65	BOLT, special, bearing connecting rod at joint ...	1	S.65	C	
10076	E.A1.31.157	BRACKET, link mounting ...	1	L.40	C/MR	TU.2
28N/12455	AGS.2031/22	CIRCLIP, external, 1 1/8" dia. ...	1	—	C	
28N/2001688	AGS.2030/22	CIRCLIP, internal, 25 m/m ...	1	—	C	
	E.A1.31.11	<b>ELEVATOR, PORT, GROUP</b>	1	—	—	
		Spares for:—				
336	E.A1.31.79	BRACKET, hinge ...	3	—	C	TU.2
337	E.A1.31.485	COVER, hand hole, between elevator rib and hinge rib	1	L.72	C	TU.2
10069	E.A1.31.487	DIAPHRAGM, tab shroud ...	3	—	C	
20752	E.A1.31.7	<b>HORN, ELEVATOR, PORT, GROUP</b>	1	—	MR	
		Spares for:—				
10016	E.A1.31.51	BRACKET, horn ...	1	DTD.300	MR	
10022	E.A1.31.551	PANEL, skin, top ...	1	—	C	
10023	E.A1.31.552	PANEL, skin, bottom ...	1	—	C	
1468	EEAS.1/2C	SCREW, 2 BA ...	3	S.11	C	
1029	EEAS.1/4C	SCREW, 2 BA ...	8	S.11	C	
10035	EEAS.1/4½E	SCREW, 1/4" BSF ...	16	S.11	C	
338	E.A1.31.91	SPIGOT, hinge ...	1	S.11	C	
10036	E.A3.31.25	<b>WEIGHT, ELEVATOR HORN BALANCE, GROUP</b>	1	—	MR	
		Consisting of:—				
19726	E.A3.31.29	BOLT, special ...	1	MS	C/MR	TU.2
19725	E.A3.31.27	DISC, balance weight ...	QR	DTD.126A	C/MR	
19715	E.A1.31.333	HORN, balance weight ...	QR	L.64	C/MR	TU.2
19716	E.A1.31.339	HOUSING, balance weight ...	1	—	MR	
28W/9416198	SP.42/J	WASHER, tab ...	1	—	C	

**TAIL UNIT  
TAILPLANE AND ELEVATORS**

Ref. No.	Part No.	Description	No. off	Matl. Spec.	Cl. of Equip.	Plate No.
					M.R. L.M.	
28W/9419477	SP.15/J	<b>WASHER</b> , ... ..	QR	—	C	
19727	E.A3.31.39	<b>WEIGHT</b> , mass balance ... ..	1	S.92	C/MR	
19728	E.A3.31.41	<b>WEIGHT</b> , mass balance ... ..	QR	S.92	C/MR	TU.2
10050	E.A1.31.83	<b>HOUSING</b> , bearing, tab spar ... ..	1	L.40	C/MR	TU.2
1531	E.A1.31.679	<b>MEMBER</b> , trailing edge ... ..	1	L.72	C/MR	
10061	E.A1.31.325	<b>PACKING</b> , trailing edge ... ..	8	Balsa Wood	C	
10074	E.A1.31.499	<b>PANEL</b> , skin, top ... ..	1	—	C	
10075	E.A1.31.501	<b>PANEL</b> , skin, bottom ... ..	1	—	C	
10042	E.A1.31.25	<b>RIB</b> , No. 2, 3 and 4 ... ..	3	—	C	
10044	E.A1.31.29	<b>RIB</b> , No. 5, tab hinge ... ..	1	—	C	
10045	E.A1.31.31	<b>RIB</b> , No. 9, tab hinge ... ..	1	—	C	
1468	EEAS.1/2C	<b>SCREW</b> , 2 BA ... ..	4	S.11	C	
1033	EEAS.1/2½E	<b>SCREW</b> , ¼" BSF ... ..	8	S.11	C	
	E.A1.31.15	<b>SPAR, ELEVATOR, MAIN PORT, GROUP</b>	1	—	MR	
		Spares for:—				
19707	E.A1.31.53	<b>BRACKET</b> , hinge, elevator centre ... ..	1	DTD.300	C	
		Attaching parts for E.A1.31.53:— (New elevators Mod. 4160)				
28D/1200119	A25/4C	Bolt, 2 BA ... ..	2	—	C	
28D/1013172	AS.1242/5C	Bolt, 2 BA ... ..	4	—	C	
28M/9403520	A27/CP	Nut, 2 BA ... ..	6	—	C	
1107	EEAS.41/8	Pin, sealing ... ..	2	—	C	
28Q/	AGS.2045/619	Rivet, chobert ... ..	2	—	—	
	E.A9.31.89	Shim (Mod. 4160) (Make from 30B/2006) ... ..	2	—	LM	
	E.A9.31.91	Shim (Mod. 4160) (Make from 30B/2006) ... ..	2	—	LM	
		Attaching parts for E.A1.31.53:— (Modified elevator Mod. 4160)				
28D/1008151	A25/4E	Bolt, ¼" BSF (Mod. 4160) ... ..	4	—	C	
28D/1204937	AS.1242/6C	Bolt, 2 BA ... ..	4	—	C	
28M/1278190	AGS.2001/C/1	Nut, 2 BA ... ..	4	—	C	
	E.A9.31.89	Shim (Mod. 4160) (Make from 30B/2006) ... ..	2	—	LM	
	E.A9.31.91	Shim (Mod. 4160) (Make from 30B/2006) ... ..	2	—	LM	
28W/1009699	SP.55/C	Washer (Mod. 4160) ... ..	4	—	C	
5206	E.A1.31.169	<b>BRACKET, BEARING, C/W BALLRACE, GROUP</b>	1	—	C	TU.2
		Spares for:—				
1042	EEAS.3/K	<b>HOUSING</b> ... ..	1	—	C	
19717	E.A1.31.421	<b>BUSH</b> , balance weight arm ... ..	1	S.95	C/MR	
19711	E.A1.31.149	<b>HINGE</b> , elevator, inboard ... ..	1	L.45	C/MR	
6940	E.A1.31.317	<b>MOUNTING, TAB TORQUE TUBE, GROUP</b>	1	—	C	TU.2
		Spares for:—				
13245	E.A1.31.215	<b>LEVER</b> , stop pin ... ..	1	S.11	C	
1091	EEAS.37/8A	<b>NIPPLE</b> , 4 BA ... ..	8	S.11	C	
5032	E.A1.31.303	<b>SHIM</b> ... ..	1	Alum.	C	
338	E.A1.31.91	<b>SPIGOT</b> , hinge ... ..	2	S.11	C	
	EEAS.38/2A	<b>SPOKE</b> , 4 BA (Make from Ref. 28R/6124) ... ..	4	S.11	—	
	HOFFMANN					
28R/13507	CF.2	<b>END-ROD</b> ... ..	1	—	C	
5982	E.A1.31.159	<b>LEVER</b> , coupling control operating rod, c/w ballrace (Pre-Mod. 2705)	1	—	B	TU.2
37749	E.A9.31.45	<b>LEVER</b> , coupling control operating rod, c/w ballrace (Mod. 2705)	1	—	C	
2115	E.A1.31.691	<b>LEVER</b> , elevator, tab operating ... ..	1	L.40	C	TU.2
10077	E.A1.31.155	<b>LINK</b> , restricting, operating lever travel ... ..	2	L.72	C/MR	TU.2
2106	E.A1.31.211	<b>NUT</b> , special, clamp torque tube ... ..	1	S.1	C	
340	E.A1.31.363	<b>PLUG</b> , elevator mechanism inspection ... ..	2	—	C	TU.2

**TAIL UNIT  
TAILPLANE AND ELEVATORS**

Ref. No.	Part No.	Description	No. off	Matl. Spec.	Cl. of Equip.	Plate No.
					M.R. L.M.	
25608	E.A3.30.273	ROD CONNECTING BETWEEN ELEVATOR TAB AND OPERATING LEVER, GROUP (MOD. 2125)	1	—	B	TU.2
		Spares for:—				
342	E.A1.31.101	END-PIECE, ball bearing rod connecting (Made from Hoffmann CF2)	1	—	B	
395	E.A1.31.99	END-PIECE ... ..	1	DTD.683	C	
343	E.A1.31.277	SHIM, tab hinge bracket ... ..	1	Alum	C	
	or					
22976	EEAS.27/8/4	TAB ELEVATOR, PORT, GROUP (MOD. 2182)	1	—	A	TU.2
26518	E.A9.31.5	(PRE-MOD. 4077)				
		Spares for:—				
4679	E.A3.31.53	ARM, support, balance weight ... ..	4	L.40	C/MR	TU.2
4160	E.A1.45.49	BOLT, special, balance weight fixing ... ..	4	—	C	
	E.A9.31.9	FITTING, tab hinge, inner, inboard ... ..	1	L.65	—	
	E.A9.31.11	FITTING, tab hinge, inner, outboard ... ..	1	L.65	—	TU.2
4163	E.A1.31.57	FITTING, tab hinge, inboard end ... ..	1	—	C/MR	
4164	E.A3.31.23	FITTING, tab hinge, outboard end ... ..	1	L.40	C/MR	
334	E.A1.31.61	PIN, special, tab bearing ... ..	3	S.11	C	
343	E.A1.31.277	SHIM, balance weight packing ... ..	4	Alum.	C	
	or					
22976	EEAS.27/8/4	TAB ELEVATOR, PORT, GROUP (MOD. 4077)	1	—	A	
34720	E.A9.31.69	Spares for this group are identical with those for group Part No. E.A9.31.5				
<del>13242</del>	<del>AC 20.</del>					
<del>13342</del>	E.A9.31.27	TORQUE TUBE AND BLOW-BACK ROD, ASSEMBLY (MOD. 2182)	1	—	A	TU.2
		Consisting of:—				
5983	E.A1.31.167	BRACKET, bearing ... ..	1	—	B/MR	
5984	E.A1.31.443	LEVER, operating ... ..	1	—	B/MR	
28M/5808573	A27/CS	NUT, 2 BA ... ..	4	—	C	
28M/13451	A29/JS	NUT, 3" BSF ... ..	1	—	C	
28P/9527619	SP.90/C7	PIN, split ... ..	5	—	C	
26519	E.A9.31.19	ROD, blow-back ... ..	1	S.11	B/MR	
1030	EEAS.1/5C	SCREW, 2 BA ... ..	4	—	C	
2108	E.A1.31.199	TUBE, tension <i>TORQUE TUBE</i> ... ..	1	—	B/MR	
28W/9419404	SP.16/C	WASHER ... ..	4	—	C	
1077	EEAS.28/34JR	WASHER, special ... ..	1	—	C	
30A/9146066	†	WIRE, locking, 18 SWG ... ..	QR	—	C	
2992	E.A1.31.3	ELEVATOR, C/W TAB, STARBOARD, GROUP	1	—	A	TU.2
		Spares for:—				
	E.A1.31.710	BALANCE, MASS ELEVATOR, STARBOARD, GROUP	1	—	—	
		Consisting of:—				
	E.A1.31.712	ARM, balance weight ... ..	1	G.E.C.	—	
				Heavy Metal		
21988	E.A1.31.713	ARM, balance weight ... ..	1	S.95	MR	
21692	E.A1.31.133	BOLT, special, make-up balance weight ... ..	2	MS	MR	
20687	E.A1.31.705	PIN, special, locking balance weight to arm ... ..	1	S.95	MR	
19724	E.A1.31.707	PLUG, screwed end fitting ... ..	1	S.95	C/MR	
43227	E.A1.31.129	WEIGHT, balance make-up ... ..	1	G.E.C.	MR	
				Heavy Metal		
30A/9140209	†	WIRE, locking, 20 SWG ... ..	QR	—	C	

**TAIL UNIT**  
**TAILPLANE AND ELEVATORS**

Ref. No.	Part No.	Description	No. off	Matl. Spec.	Cl. of Equip.		Plate No.
					M.R.	L.M.	
		1 2 3 4 5 6					
2A/9500463	SKEFKO. CBA. 2	BEARING, ballrace, elevator tab ... ..	1	—	C		
333	E.A1.31.63	BOLT, special, bearing tab hinge ... ..	1	S.11	C		
328	E.A1.31.65	BOLT, special, bearing connecting rod at joint ...	1	—	C		
346	E.A1.31.275	BOLT, special, stop ... ..	1	L.40	C		
28N/1001688	AGS.2030/22	CIRCLIP, internal, 25 m/m ... ..	1	—	C		TU.2
	E.A1.31.13	ELEVATOR, STARBOARD, GROUP ... ..	1	—	MR		
		Spares for:—					
336	E.A1.31.79	BRACKET, hinge ... ..	3	—	C		
337	E.A1.31.485	COVER, hand hole, between elevator rib and hinge rib	1	L.72	C		
10069	E.A1.31.487	DIAPHRAGM, tab shroud ... ..	3	—	C		
41981	E.A1.31.8	HORN, ELEVATOR, GROUP ... ..	1	—	MR		
		Spares for:—					
10017	E.A1.31.52	BRACKET, horn ... ..	1	DTD.300	MR		
10022	E.A1.31.551	PANEL, skin, top ... ..	1	—	C		
10023	E.A1.31.552	PANEL, skin, bottom ... ..	1	—	C		
1468	EEAS.1/2C	SCREW, 2 BA ... ..	3	S.11	C		
1029	EEAS.1/4C	SCREW, 2 BA ... ..	8	S.11	C		
10035	EEAS.1/4½E	SCREW, ¼" BSF ... ..	16	S.11	C		
338	E.A1.31.91	SPIGOT, hinge ... ..	1	S.11	C		
10036	E.A3.31.25	WEIGHT, ELEVATOR HORN BALANCE, GROUP	1	—	MR		
		Consisting of:—					
19726	E.A3.31.29	BOLT, special ... ..	1	MS	C/MR		TU.2
19725	E.A3.31.27	DISC, balance weight ... ..	1	DTD.126A	C/MR		
19715	E.A1.31.333	DISC, balance weight ... ..	QR	L.64	C/MR		TU.2
19716	E.A1.31.339	HOUSING, balance weight ... ..	1	—	MR		
28W/9419477	SP.15/J	WASHER, ¾" BSF ... ..	QR	—	C		
28W/9416198	SP.42/J	WASHER, tab ... ..	1	—	C		
19727	E.A3.31.39	WEIGHT, mass balance ... ..	1	S.92	C/MR		
19728	E.A3.31.41	WEIGHT, mass balance ... ..	QR	S.92	C/MR		TU.2
10050	E.A1.31.83	HOUSING, bearing, tab spar ... ..	1	L.40	C/MR		TU.2
1531	E.A1.31.679	MEMBER, trailing edge ... ..	1	L.72	C/MR		
10061	E.A1.31.325	PACKING, trailing edge ... ..	8	Balsa Wood	C		
10074	E.A1.31.499	PANEL, skin, top ... ..	1	—	C		
10075	E.A1.31.501	PANEL, skin, bottom ... ..	1	—	C		
10045	E.A1.31.31	RIB, No. 5 and 9, tab hinge ... ..	2	—	C		
1468	EEAS.1/2C	SCREW, 2 BA ... ..	4	S.11	C		
1033	EEAS.1/2½E	SCREW, ¼" BSF ... ..	6	—	C		
	E.A1.31.17	SPAR, ELEVATOR, MAIN, STARBOARD, GROUP	1	—	MR		
		Spares for:—					
19707	E.A1.31.53	BRACKET, hinge, elevator centre ... ..	1	DTD.300	C		
		Attaching parts for E.A1.31.53:— (New elevator's Mod. 4160)					
28D/1200119	A25/4C	Bolt, 2 BA ... ..	2	—	C		
28D/1013172	AS.1252/5C	Bolt, 2 BA ... ..	4	—	C		
28M/9403520	A27/CP	Nut, 2 BA ... ..	6	—	C		
1107	EEAS..41/8	Pin, sealing ... ..	2	—	C		
28Q/	AGS.2045/619	Rivet, chobert ... ..	2	—	—		
	E.A9.31.89	Shim (Mod. 4160) (Make from 30B/2006) ...	2	—	LM		
	E.A9.31.91	Shim (Mod. 4160) (Make from 30B/2006) ...	2	—	LM		

**TAIL UNIT  
TAILPLANE AND ELEVATORS**

Ref. No.	Part No.	Description	No. off	Matl. Spec.	Cl. of Equip.		Plate No.
					M.R.	L.M.	
		Attaching parts for E.A1.31.53:— (Modified elevator's Mod. 4160)					
28D/1008151	A25/4E	Bolt; 1/4" BSF (Mod. 4160) ... ..	4	—		C	
28D/1204937	AS.1242/6C	Bolt; 2 BA ... ..	4	—		C	
28M/1278190	AGS.2001/C/1	Nut; 2 BA ... ..	4	—		C	
	E.A9.31.89	Shim (Mod. 4160) (Make from 30B/2006) ...	2	—		LM	
	E.A9.31.91	Shim (Mod. 4160) (Make from 30B/2006) ...	2	—		LM	
28W/1009699	SP.55/C	Washer (Mod. 4160) ... ..	4	—		C	
19717	E.A1.31.421	<b>BUSH</b> , balance weight arm ... ..	1	S.95		C/MR	
5207	E.A1.31.151	<b>HINGE</b> , elevator, inboard ... ..	1	L.45		C	
1091	EEAS.37/8A	<b>NIPPLE</b> , 4 BA ... ..	8	S.11		C	
338	E.A1.31.91	<b>SPIGOT</b> , hinge ... ..	1	S.11		C	
	EEAS.38/2A	<b>SPOKE</b> , 4 BA (Make from 28R/6124) ... ..	4	S.11		C	
21546	E.A1.31.351	<b>LEVER</b> , stop, coupling arm attachment ...	1	DTD.683		C	
10091	E.A1.31.271	<b>LEVER, COUPLING CONTROL, GROUP...</b> (PRE-MOD. 2705)	1	—		C	
		Spares for:—					
346	E.A1.31.275	<b>BOLT</b> , special, stop ... ..	1	L.40		C	
5982	E.A1.31.159	<b>LEVER</b> ... ..	1	—		—	
28M/1007404	A27/JT	<b>NUT</b> , 3/8" BSF ... ..	1	—		—	
37750	E.A9.31.47	<b>LEVER, COUPLING CONTROL, GROUP</b> <b>MOD. 2705)</b>	1	—		—	
		Consisting of:—					
346	E.A1.31.275	<b>BOLT</b> , special, stop ... ..	1	L.40		C	
37749	E.A9.31.45	<b>LEVER</b> ... ..	1	—		C	
28M/1007404	A27/JT	<b>NUT</b> , 3/8" BSF ... ..	1	—		C	
340	E.A1.31.363	<b>PLUG</b> , elevator mechanism inspection ...	2	—		C	TU.2
2922	E.A1.31.105	<b>ROD</b> , connecting elevator tab gear ... ..	1	—		C	
343	E.A1.31.277	<b>SHIM</b> , connecting rod attachment tab ...	1	Alumn.		C	
	or						
22976	EEAS.27/8/4						
3370	E.A1.31.6	<b>TAB, ELEVATOR, STARBOARD, GROUP (PRE-</b> <b>MOD. 4078)</b>	1	—		A	TU.2
		Spares for:—					
4679	E.A3.31.53	<b>ARM</b> , support, balance weight ... ..	12	L.40		C/MR	TU.2
4160	E.A1.45.59	<b>BOLT</b> , special, balance weight fixing ...	12	—		C/MR	
4161	E.A1.31.50	<b>FITTING</b> , tab hinge, inner, inboard ... ..	1	L.40		C/MR	TU.2
4155	E.A1.31.55	<b>FITTING</b> , tab hinge, outboard ... ..	1	L.40		C/MR	TU.2
4164	E.A3.31.23	<b>FITTING</b> , tab hinge, outboard end ... ..	1	—		C/MR	TU.2
4165	E.A1.31.449	<b>FITTING</b> , tab hinge, inboard end ... ..	1	—		C/MR	TU.2
334	E.A1.31.61	<b>PIN</b> , special, tab bearing ... ..	3	S.11		C	
343	E.A1.31.277	<b>SHIM</b> , balance weight packing ... ..	6	Alumn.		C	
	or						
22976	EEAS.27/8/4						
34719	E.A3.31.127	<b>TAB, ELEVATOR, STARBOARD, GROUP (MOD.</b> <b>4078)</b>	1	—		A	
		Spares for this group are identical with those for group Part No. E.A1.31.6					
1077	EEAS.28/34JR	<b>WASHER</b> , special ... ..	1	—		C	TU.2

**TAIL UNIT  
TAILPLANE AND ELEVATORS**

Ref. No.	Part No.	1	2	3	4	5	6	Description	No. off	Matl. Spec.	Cl. of Equip.			Plate No.
											M.R.	L.M.		
3075	E.A1.30.1147							FAIRING, DETACHABLE ROOT, PORT, ASSEMBLY (PRE-MOD. 1277)	1	—		B		
3076	E.A1.30.1148							FAIRING, DETACHABLE ROOT, STARBOARD, ASSEMBLY (PRE-MOD. 1277)	1	—		B		
13125	E.A9.00.377	✓						FAIRING, DETACHABLE ROOT, PORT, ASSEMBLY (MOD. 1277)	1	—		B		
13126	E.A9.00.378	✓						FAIRING, DETACHABLE ROOT, STARBOARD, ASSEMBLY (MOD. 1277)	1	—		B		
3085	E.A1.30.1107	✓						PANEL, access, tail-rod actuator ... ..	1	L.72		C		
3383	E.A3.31.43							LINK, connecting elevator operating levers ... ..	1	DTD.683		C		TU.2
3384	E.A3.31.49							PLATE, locking, for serrated bush ... ..	1	S.95		C		
10990	E.A1.31.279							ROD-END, c/w ballrace, tab operating ... ..	1	—		C		
31468	E.B8.31.31							SCREW, special, connecting between connecting rod and end-piece (Mod. 3330)	1	L.40		C		
6942	E.B6.30.1							TAILPLANE, GROUP (PRE-MOD. 1277) ... ..	1	—		A		
4175	E.A1.30.297							BOLT, special, mounting between main spar and tailplane structure, bottom, port and starboard	4	S.65		C/MR		
4176	E.A1.30.299							BOLT, special, mounting between main spar and tailplane structure, top, port and starboard	4	S.65		C/MR		
4177	E.A1.30.321							BOLT, special, jointing at rib 3 to main spar bracket	8	DTD.473		C/MR		
4386	E.A1.30.323	✓						BOLT, special, jointing at rib 1 to main spar bracket	4	S.11		C/MR		
10919	E.A1.30.413	✓						BRACKET, TAILPLANE ACTUATOR CHANNEL, GROUP	1	—		C		
21343	E.A1.30.379	—						BOLT, special ... ..	4	S.65		C		
352	E.A1.30.279	—						BUSH, bearing ... ..	2	S.1		C		
353	E.A1.30.277	—						PIN, attachment ... ..	1	S.11		C		
13170	E.A1.30.5	—						EDGE, LEADING, TAILPLANE, PORT, ASSEMBLY	1	—		C		
35893	E.B8.30.99							RIB, No. 2, INSTALLATION (MOD. 2334) ...	1	—		MR		
35895	E.B8.30.339							ANGLE, attachment ... ..	1	—		C		
35912	E.B8.30.375							BOOM, tee ... ..	1	—		C		
35914	E.B8.30.377							PACKING ... ..	1	—		C		
	E.A9.30.81							RIB, No. 2 ... ..	1	—		C		
33521	E.B8.30.89							STIFFENER ... ..	1	—		C		
10920	E.A1.30.69							RIB, No. 3 ... ..	1	—		C		
10921	E.A1.30.71							RIB, No. 4 ... ..	1	—		C		
10922	E.A1.30.73							RIB, No. 5 ... ..	1	—		C		
10923	E.A1.30.75							RIB, No. 6 ... ..	1	—		C		
10924	E.A1.30.77							RIB, No. 7 ... ..	1	—		C		
10925	E.A1.30.79							RIB, No. 8 ... ..	1	—		C		
10926	E.A1.30.81							RIB, No. 9 ... ..	1	—		C		
10927	E.A1.30.83							RIB, No. 10 ... ..	1	—		C		
10928	E.A1.30.85							RIB, No. 11 ... ..	1	—		C		
10929	E.A1.30.87							RIB, No. 12 ... ..	1	—		C		
10930	E.A1.30.89							RIB, No. 13 ... ..	1	—		C		

**TAIL UNIT  
TAILPLANE AND ELEVATORS**

Ref. No.	Part No.	Description	No. off	Matl. Spec.	Cl. of Equip.		Plate No.
					M.R.	L.M.	
		1 2 3 4 5 6					
12061	E.A1.30.6	<b>EDGE, LEADING, TAILPLANE, STARBOARD, ASSEMBLY</b>	1	—		C	
		Spares for:—					
35894	E.B8.30.100	<b>RIB, NO. 2, INSTALLATION (MOD. 2334) ...</b>	1	—		MR	
		Spares for:—					
35896	E.B8.30.340	<b>ANGLE, attachment ...</b>	1	—		C	
35913	E.B8.30.376	<b>BOOM, tee ...</b>	1	—		C	
35914	E.B8.30.377	<b>PACKING ...</b>	1	—		C	
34405	E.A9.30.82	<b>RIB, No. 2 ...</b>	1	—		C	
33522	E.B8.30.90	<b>STIFFENER ...</b>	1	—		C	
10920	E.A1.30.69	<b>RIB, No. 3 ...</b>	1	—		C	
10921	E.A1.30.71	<b>RIB, No. 4 ...</b>	1	—		C	
10922	E.A1.30.73	<b>RIB, No. 5 ...</b>	1	—		C	
10923	E.A1.30.75	<b>RIB, No. 6 ...</b>	1	—		C	
10924	E.A1.30.77	<b>RIB, No. 7 ...</b>	1	—		C	
10925	E.A1.30.79	<b>RIB, No. 8 ...</b>	1	—		C	
10926	E.A1.30.81	<b>RIB, No. 9 ...</b>	1	—		C	
10927	E.A1.30.83	<b>RIB, No. 10 ...</b>	1	—		C	
10928	E.A1.30.85	<b>RIB, No. 11 ...</b>	1	—		C	
10929	E.A1.30.87	<b>RIB, No. 12 ...</b>	1	—		C	
10930	E.A1.30.89	<b>RIB, No. 13 ...</b>	1	—		C	
	E.A1.30.7	<b>EDGE, TRAILING, TAILPLANE, PORT, GROUP</b>	1	—		MR	
		Spares for:—					
10962	E.A1.30.121	<b>BOLT, special, mounting, centre hinge bracket</b>	2	S.11		C/MR	
354	E.A1.30.49	<b>BRACKET, HINGE, ELEVATOR, OUTBOARD, GROUP</b>	1	—		B	
		Spares for:—					
2A/9500441	SKEFKO B.A.L.½	<b>BALLRACE ...</b>	1	BSS.292		C	
355	E.A1.30.401	<b>HOUSING, ballrace ...</b>	1	DTD.683		C	
1774	EEAS.4/20G	<b>WASHER, packing, 20 SWG ...</b>	1	L.72		C	
356	E.A1.30.117	<b>BRACKET, HINGE, ELEVATOR, CENTRE PORT, GROUP</b>	1	—		B	
		Spares for:—					
2A/9500441	SKEFKO B.A.L.½	<b>BALLRACE ...</b>	1	BSS.292		C	TU.2
357	E.A1.30.399	<b>HOUSING, ballrace ...</b>	1	DTD.683		C	
21689	E.A1.30.403	<b>CHANNEL, reinforcing ...</b>	1	—		C	
27136	E.A1.30.405	<b>CHANNEL, reinforcing ...</b>	1	—		C	
12920	E.A1.30.383	<b>CUP, sealing, elevator lock recess ...</b>	2	L.40		C	
5019	E.A1.30.261	<b>SHIM, plate ...</b>	1	—		C	
	E.A1.30.8	<b>EDGE, TRAILING, TAILPLANE, STARBOARD GROUP</b>	1	—		—	
		Spares for:—					
10962	E.A1.30.121	<b>BOLT, special, mounting, centre hinge bracket</b>	2	S.11		C/MR	
21573	E.A1.30.313	<b>BOLT, special, mounting ...</b>	2	S.11		C/MR	
354	E.A1.30.49	<b>BRACKET, HINGE, ELEVATOR, OUTBOARD GROUP</b>	1	—		B	
		Spares for:—					
2A/9500441	SKEFKO B.A.L.½	<b>BALLRACE ...</b>	1	—		C	
355	E.A1.30.401	<b>HOUSING, ballrace ...</b>	1	—		C	
1774	EEAS.4/20G	<b>WASHER, packing, 20 SWG ...</b>	1	L.72		C	
356	E.A1.30.117	<b>BRACKET, HINGE, ELEVATOR, CENTRE, STARBOARD, GROUP</b>	1	—		B	TU.2
		Spares for:—					
2A/9500441	SKEFKO B.A.L.½	<b>BALLRACE ...</b>	1	—		C	
357	E.A1.30.399	<b>HOUSING, ballrace ...</b>	1	DTD.683		C	

**TAIL UNIT  
TAILPLANE AND ELEVATORS**

Ref. No.	Part No.	Description	No. off	Matl. Spec.	Cl. of Equip.		Plate No.
					M.R.	L.M.	
		1 2 3 4 5 6					
5178	E.A1.30.291	BRACKET, stop, elevator, lower ... ..	1	—	C		
5177	E.A1.30.293	BRACKET, stop, elevator, upper ... ..	1	—	C		
21569	E.A1.30.315	BRACKET, tab operating ... ..	1	—	MR		
26365	E.A1.30.404	CHANNEL, reinforcing ... ..	1	—	MR		
27137	E.A1.30.406	CHANNEL, reinforcing ... ..	1	—	MR		
12920	E.A1.30.383	CUP, sealing, elevator lock recess ... ..	2	L.40	C		
5019	E.A1.30.261	SHIM, plate ... ..	1	—	C		
6862	E.A3.30.43	FAIRING, tailplane tip ... ..	2	—	C		
6735	E.A1.31.307	HOUSING BEARING, CENTRE CONTROL, PORT, ASSEMBLY Consisting of:—	1	—	B		TU.2
2A/9500470	SKEFKO CBA.5	BEARING, ballrace ... ..	1	—	C		
28N/12452	AGS.2030/57	CIRCLIP, internal, 50 m/m ... ..	1	—	C		
	E.A1.31.45	HOUSING, bearing ... ..	1	—	—		
6736	E.A1.31.308	HOUSING BEARING, CENTRE CONTROL, STARBOARD, ASSEMBLY Consisting of:—	1	—	B		TU.2
2A/9500470	SKEFKO CBA.5	BEARING, ballrace ... ..	1	—	C		
28N/12452	AGS.2030/57	CIRCLIP, internal, 50 m/m ... ..	1	—	C		
	E.A1.31.46	HOUSING, bearing ... ..	1	—	—		
1103	EEAS.41/3	PINS, sealing ... ..	42	—	C		
1105	EEAS.41/5	PINS, sealing ... ..	60	—	C		
5353	E.A1.30.783	PLATE, sealing, top, port ... ..	1	—	MR		
5354	E.A1.30.784	PLATE, sealing, top, starboard ... ..	1	—	MR		
26095	E.A1.30.175	PLATE, side, mounting, inboard hinge port ... ..	1	—	C		
26096	E.A1.30.176	PLATE, side, mounting, inboard hinge, starboard ... ..	1	—	C		
18609	E.A3.30.131	PLATE, closing, port ... ..	1	—	MR		
18610	E.A3.30.132	PLATE, closing, starboard ... ..	1	—	MR		
5073	EEAS.65	PLATE, serial record ... ..	1	—	C		
18607	E.A3.30.107	PLATE, tappet ... ..	1	DTD.683	C		
18608	E.A3.30.108	PLATE, tappet ... ..	1	DTD.683	C		
5031	E.A1.31.441	SHIM, centre bearing housing ... ..	2	—	C		
38088	E.A1.30.389	SKIN, fixed fairing, port (To E.A3.00.937 for spares)	1	—	C/MR		
38089	E.A1.30.390	SKIN, fixed fairing, starboard (To E.A3.00.938 for spares)	1	—	C/MR		
	E.A1.30.33	SPAR, MAIN, TAILPLANE, CENTRE SECTION, GROUP Spares for:—	1	—	—		
5869	E.A3.30.145	BUSH, hinge ... ..	4	S.99	C		
40071	E.A1.30.263	FORK, bottom ... ..	2	S.65	MR		
27460	E.A1.30.265	FORK, top ... ..	2	S.65	MR		
5020	E.A1.30.267	SHIM ... ..	4	Alumn.	C		
7207	E.A1.30.415	VANE, sealing, port ... ..	1	—	MR		
7239	E.A1.30.416	VANE, sealing, starboard ... ..	1	—	MR		
1073	EEAS.28/15JR	WASHER, 10 SWG ... ..	8	L.72	C		

**TAIL UNIT  
TAILPLANE AND ELEVATORS**

Ref. No.	Part No.	Description	No. off	Matl. Spec.	Cl. of Equip.		Plate No.
					M.R.	L.M.	
		1 2 3 4 5 6					
1077	EEAS.28/34JR	WASHER ... ..	4	—			C
1079	EEAS.28/38JR	WASHER ... ..	4	—			C
22288	E.A1.30.289	WASHER, fillet, actuator bracket ... ..	4	—			MR
13127	E.A9.00.125	<b>TAILPLANE, GROUP (MOD. 1277) (PRE-MOD. 2148)</b>	1	—			A
		Spares for this group are identical with those for group Part No. E.B6.30.1 on page 1752, except for the following additions:					
		Add:—					
	E.A9.30.27	<b>SEALING, TAILPLANE, TO RUDDER STUB, PORT, GROUP (MOD. 1277)</b>	—	—			—
		Spares for:—					
24750	E.A3.30.265	PLATE, insert ... ..	1	—			C
24752	E.A3.30.267	PLATE, insert ... ..	1	—			C
24713	E.A9.30.35	SPRING-SEAL, assembly ... ..	1	—			C
24715	E.A9.30.39	SPRING-SEAL, assembly ... ..	1	—			C
	E.A9.30.28	<b>SEALING, TAILPLANE TO RUDDER STUB, STARBOARD, GROUP (MOD. 1277)</b>	—	—			—
		Spares for:—					
24751	E.A3.30.266	PLATE, insert ... ..	1	—			C
24753	E.A3.30.268	PLATE, insert ... ..	1	—			C
24714	E.A9.30.36	SPRING-SEAL, assembly ... ..	1	—			C
24716	E.A9.30.40	SPRING-SEAL, assembly ... ..	1	—			C
	E.A9.30.7	<b>SEALING, TAILPLANE TO TAILPLANE STUB, PORT, GROUP (MOD. 1277)</b>	—	—			—
		Spares for:—					
24697	E.A9.30.9	BLOCK ... ..	1	—			C
24699	E.A9.30.11	BLOCK ... ..	1	—			C
24705	E.A9.30.17	BLOCK ... ..	1	—			C
24707	E.A9.30.19	BLOCK ... ..	1	—			C
24701	E.A9.30.13	PACKING ... ..	1	—			C
24703	E.A9.30.15	PACKING ... ..	1	—			C
24709	E.A9.30.21	PACKING ... ..	1	—			C
24711	E.A9.30.23	PACKING ... ..	1	—			C
	E.A9.30.8	<b>SEALING, TAILPLANE TO TAILPLANE STUB, STARBOARD, GROUP (MOD. 1277)</b>	—	—			—
		Spares for:—					
24698	E.A9.30.10	BLOCK ... ..	1	—			C
24700	E.A9.30.12	BLOCK ... ..	1	—			C
24706	E.A9.30.18	BLOCK ... ..	1	—			C
24708	E.A9.30.20	BLOCK ... ..	1	—			C
24702	E.A9.30.14	PACKING ... ..	1	—			C
24704	E.A9.30.16	PACKING ... ..	1	—			C
24710	E.A9.30.22	PACKING ... ..	1	—			C
24712	E.A9.30.24	PACKING ... ..	1	—			C
31025	E.A9.00.131	<b>TAILPLANE, GROUP (MOD. 2148) ... ..</b>	1	—			A
		Spares for this group are identical with those for group Part No. E.A9.00.125 except for the following deletions and additions					
		Delete:—					
18609	E.A3.30.131	PLATE, closing, port ... ..	1	—			MR
18610	E.A3.30.132	PLATE, closing, starboard ... ..	1	—			MR
		Add:—					
28723	E.A9.30.75	PLATE, closing, port ... ..	1	—			MR
28724	E.A9.30.76	PLATE, closing, starboard ... ..	1	—			MR

**TAIL UNIT  
TAILPLANE AND ELEVATORS**

Ref. No.	Part No.	1	2	3	4	5	6	Description	No. off	Matl. Spec.	Cl. of Equip.		Plate No.
											M.R.	L.M.	
5980	E.B6.30.21	✓						<b>TAPPET, MICRO SWITCH, TAILPLANE TRAVEL LIMIT, GROUP</b>	1	—		C	TU.2
								Consisting of:—					
	E.B6.30.25							<b>BODY</b> , tappet ... ..	1	L.40		—	
	E.A1.30.371							<b>COLLAR</b> ... ..	1	L.56		—	
	E.B6.30.23							<b>PIN</b> , tappet ... ..	1	L.40		—	
28P/1203253	SP.65/E4							<b>PIN</b> , taper, $\frac{1}{8}$ " dia. x $\frac{1}{2}$ " long ... ..	1	L.A.		C	
	E.B6.30.27							<b>SPRING</b> , compression ... ..	1	DTD.215		—	
25609	E.B6.30.19	✓						<b>TAPPET, MICRO SWITCH, TAILPLANE TRAVEL LIMIT, GROUP (MOD. 2125)</b>	2	—		C	TU.2
								Consisting of:—					
	E.B6.30.25							<b>BODY</b> , tappet ... ..	1	L.40		—	
	E.A1.30.371							<b>COLLAR</b> ... ..	1	L.56		—	
	E.A3.30.271							<b>PIN</b> , tappet ... ..	1	L.64		—	
	E.B6.30.27							<b>SPRING</b> , compression ... ..	1	DTD.215		—	
360	E.A1.31.165							<b>WASHER</b> , special ... ..	2	L.64		C	
345	E.A1.31.361							<b>WASHER</b> , special ... ..	2	L.72		C	

1757

Pages ~~1757~~<sup>5/12/11</sup> to 1776 not issued

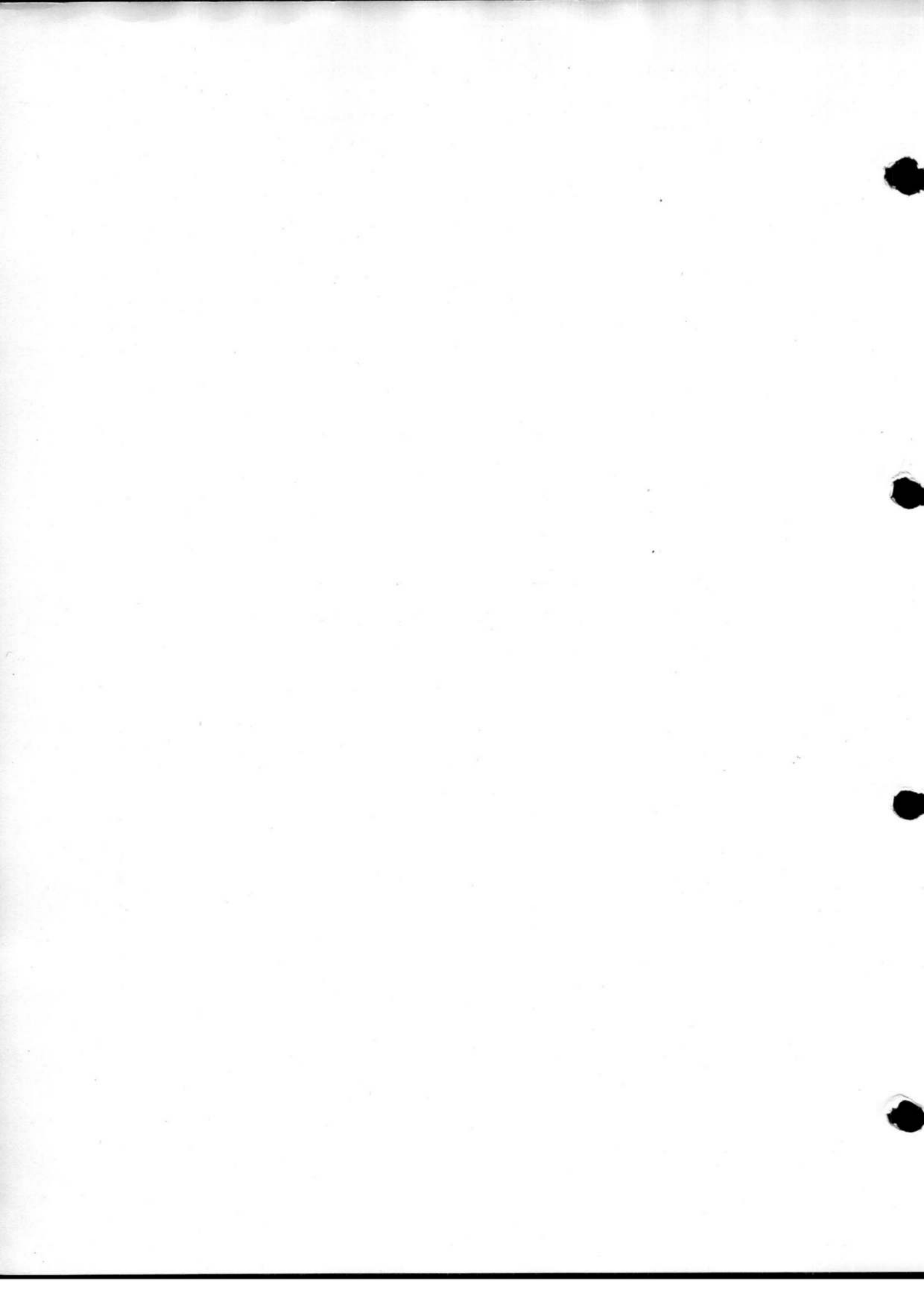

**TAIL UNIT  
TAILPLANE AND ELEVATORS**

Ref. No.	Part No.	Description						off	Matl. Spec.	Cl. of Equip. M.R. L.M.	Plate No.
		1	2	3	4	5	6				
<b>SUMMARY OF STOCK ITEMS USED ON TAILPLANE AND ELEVATORS, ASSEMBLY</b>											
28D/9133011	A25/2C	Bolt, 2	BA	hex. head,	0"65	long	...	...	...	C	
28D/9133012	A25/3C	Bolt, 2	BA	hex. head,	0"75	long	...	...	...	C	
28D/1200119	A25/4C	Bolt, 2	BA	hex. head,	0"85	long	...	...	...	C	
28D/1011019	A25/8C	Bolt, 2	BA	hex. head,	1"25	long	...	...	...	C	
28D/1008151	A25/4E	Bolt, 1	BSF	hex. head,	0"9	long	...	...	...	C	
28D/1011240	A25/5E	Bolt, 1	BSF	hex. head,	1"	long	...	...	...	C	
28D/1011242	A25/7E	Bolt, 1	BSF	hex. head,	1"2	long	...	...	...	C	
28D/1010031	A25/8E	Bolt, 1	BSF	hex. head,	1"3	long	...	...	...	C	
28D/1202771	A25/4G	Bolt, 1	BSF	hex. head,	0"95	long	...	...	...	C	
28D/1011256	A25/5G	Bolt, 1	BSF	hex. head,	1"05	long	...	...	...	C	
28D/1011257	A25/7G	Bolt, 1	BSF	hex. head,	1"25	long	...	...	...	C	
28D/1202326	A25/14J	Bolt, 1	BSF	hex. head,	2"05	long	...	...	...	C	
28D/1011311	A25/10L	Bolt, 1	BSF	hex. head,	1"7	long	...	...	...	C	
28D/1214091	AS.1242/2C	Bolt, 2	BA	c'sk. head,	0"6	long	...	...	...	C	
28D/9709461	AS.1242/3C	Bolt, 2	BA	c'sk. head,	0"7	long	...	...	...	C	
28D/1007976	AS.1242/4C	Bolt, 2	BA	c'sk. head,	0"8	long	...	...	...	C	
28D/9140203	AS.1246/3C	Bolt, 2	BA	round head,	0"7	long	...	...	...	C	
28N/9153394	AGS.899/6	Collar	...	...	...	...	...	...	...	C	
28M/6039	A18/JS	Nut, 1	BSF	slotted	...	...	...	...	...	C	
28M/9403520	A27/CP	Nut, 2	BA	plain	...	...	...	...	...	C	
28M/5808573	A27/CS	Nut, 2	BA	slotted	...	...	...	...	...	C	
28M/1006473	A27/CT	Nut, 2	BA	thin	...	...	...	...	...	C	
28M/1011475	A27/EP	Nut, 1	BSF	plain	...	...	...	...	...	C	
28M/1011467	A27/ES	Nut, 1	BSF	slotted	...	...	...	...	...	C	
28M/1007403	A27/ET	Nut, 1	BSF	thin	...	...	...	...	...	C	
28M/1006939	A27/GP	Nut, 1	BSF	plain	...	...	...	...	...	C	
28M/5808571	A27/GS	Nut, 1	BSF	slotted	...	...	...	...	...	C	
28M/1011470	A27/GT	Nut, 1	BSF	thin	...	...	...	...	...	C	
28M/1011476	A27/JS	Nut, 1	BSF	slotted	...	...	...	...	...	C	
28M/1007404	A27/JT	Nut, 1	BSF	thin	...	...	...	...	...	C	
28M/13811	A27/JTL	Nut, 1	BSF	thin, L.H.	...	...	...	...	...	C	
28M/13376	A29/EP	Nut, 1	BSF	plain	...	...	...	...	...	C	
28M/7683	AGS.572/A	Nut, 1	BSF	thin, slotted	...	...	...	...	...	C	
28M/10328	AGS.2002/C/1	Nut, stiff,	2	BA	...	...	...	...	...	C	
28M/10330	AGS.2002/E/1	Nut, stiff,	1	BSF	...	...	...	...	...	C	
28M/11957	AGS.2007/C/1	Nut, stiff,	2	BA	...	...	...	...	...	C	
28P/9527619	SP.90/C7	Pin, split,	1/16	dia. x 1"	long	...	...	...	...	C	
28P/19233	SP.90/E6	Pin, split,	3/32	dia. x 1"	long	...	...	...	...	C	
28P/19234	SP.90/E8	Pin, split,	3/32	dia. x 1 1/4"	long	...	...	...	...	C	
28P/9528015	SP.90/G8	Pin, split,	1/8	dia. x 1 1/4"	long	...	...	...	...	C	
28P/19157	SP.90/G10	Pin, split,	1/8	dia. x 1 1/2"	long	...	...	...	...	C	
28P/901	SP.4Y/F11	Pin, shackle	...	...	...	...	...	...	...	C	
28P/903	SP.4Y/F13	Pin, shackle	...	...	...	...	...	...	...	C	
28S/9435716	A33/B12	Screw, 4	BA	c'sk. head,	3/8"	long	...	...	...	C	
28S/9140929	A33/C12	Screw, 2	BA	c'sk. head,	3/8"	long	...	...	...	C	
28S/1200053	A33/C16	Screw, 2	BA	c'sk. head,	1/2"	long	...	...	...	C	
28W/9419475	SP.15/C	Washer, 2	BA	plain	...	...	...	...	...	C	
28W/9419405	SP.15/E	Washer, 1	BSF	plain	...	...	...	...	...	C	
28W/9419476	SP.15/G	Washer, 1	BSF	plain	...	...	...	...	...	C	
28W/9419404	SP.16/C	Washer, 2	BA	plain	...	...	...	...	...	C	
28W/9419487	SP.16/E	Washer, 1	BSF	plain	...	...	...	...	...	C	

**TAIL UNIT  
TAILPLANE AND ELEVATORS**

Ref. No.	Part No.	Description						off	Matl. Spec.	Cl. of Equip.			Plate No.
		1	2	3	4	5	6			M.R.	L.M.		
28W/9419489	SP.16/J	Washer,	$\frac{3}{8}$ "	BSF, plain	...	...	...	...			C		
28W/9419491	SP.16/N	Washer,	$\frac{1}{2}$ "	BSF, plain	...	...	...	...			C		
28W/9419492	SP.16/P	Washer,	$\frac{9}{16}$ "	BSF, plain	...	...	...	...			C		
28W/9419493	SP.16/Q	Washer,	$\frac{3}{8}$ "	BSF, plain	...	...	...	...			C		

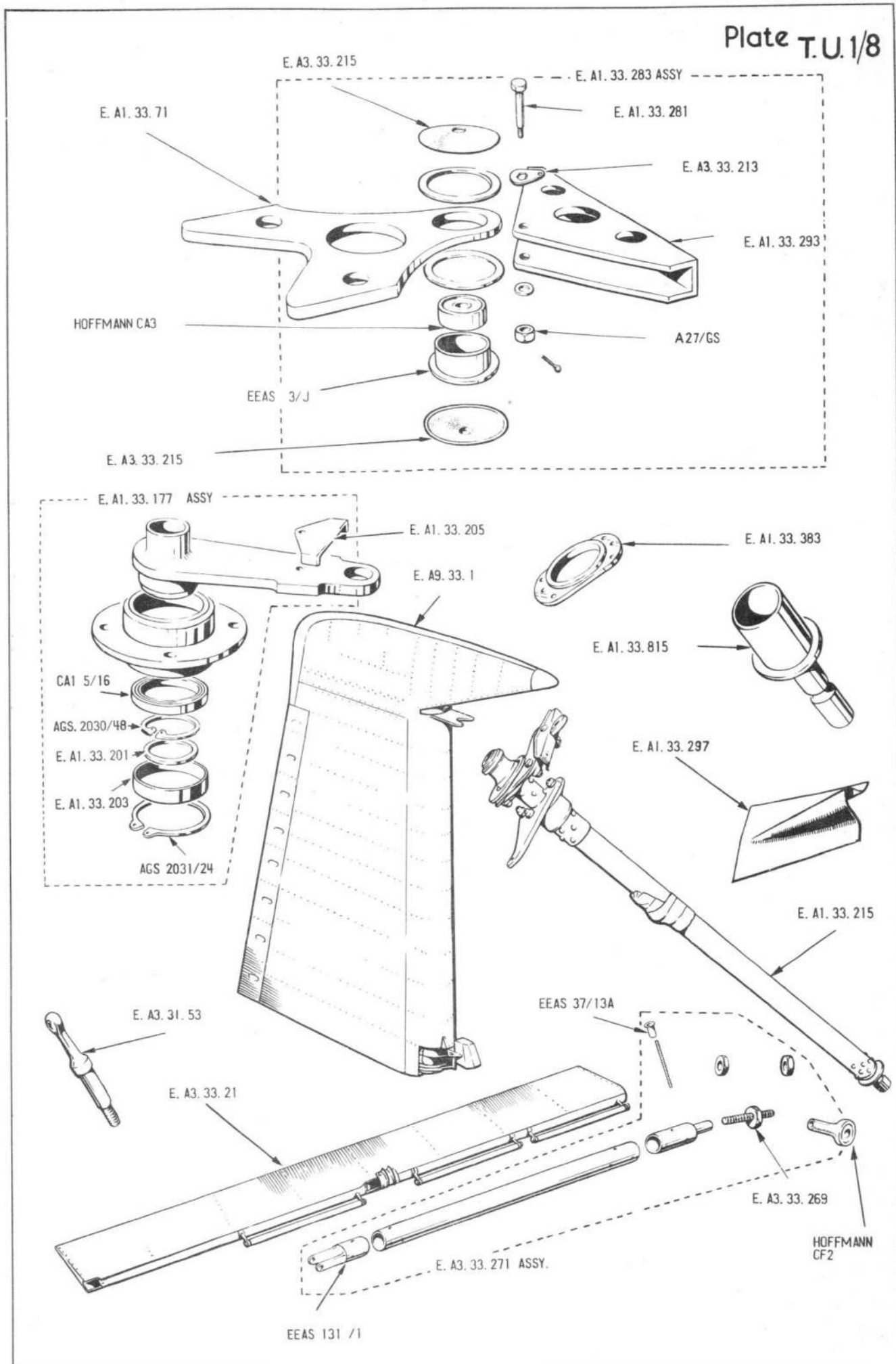

RUDDER AND TAB OPERATING GEAR

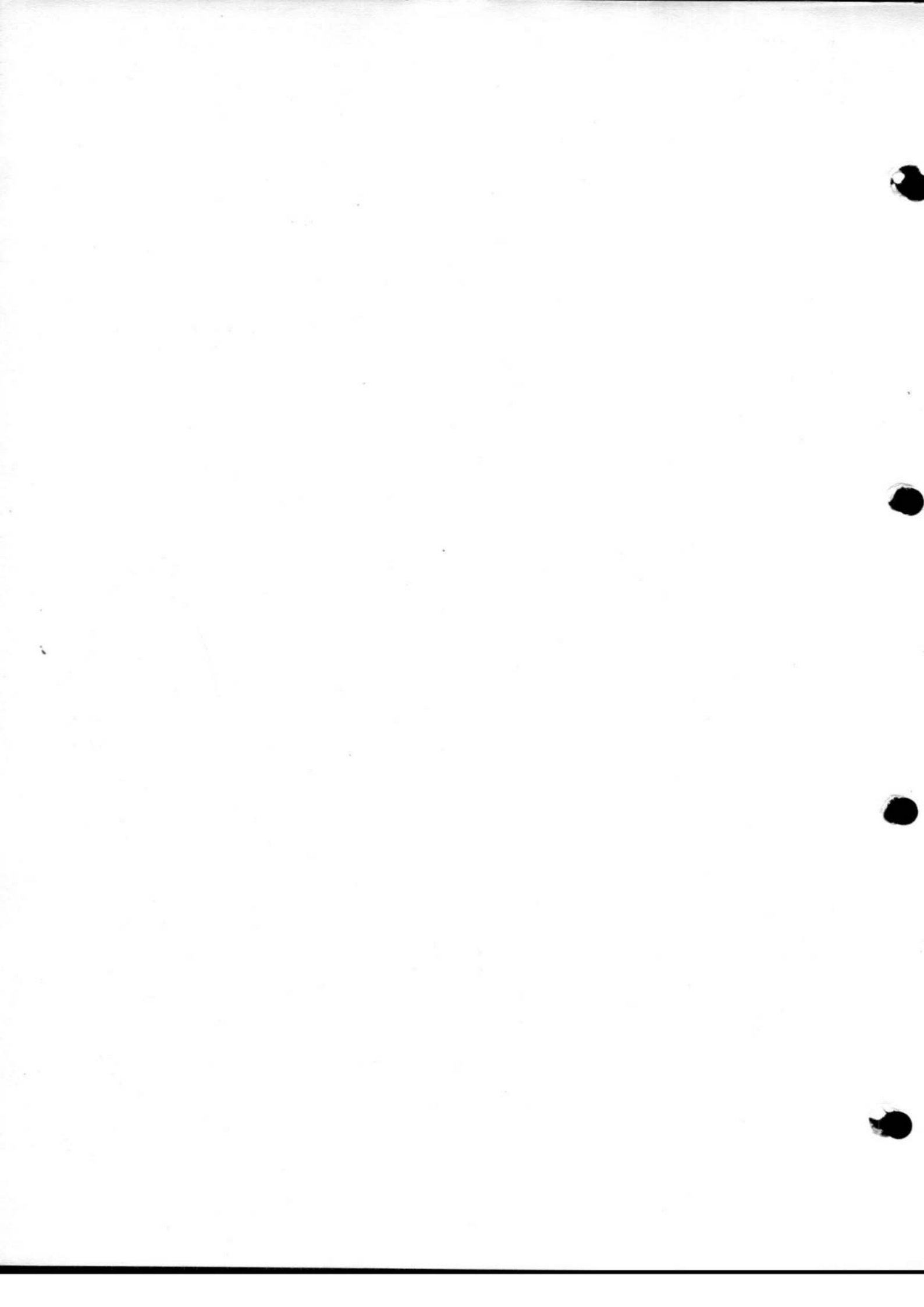

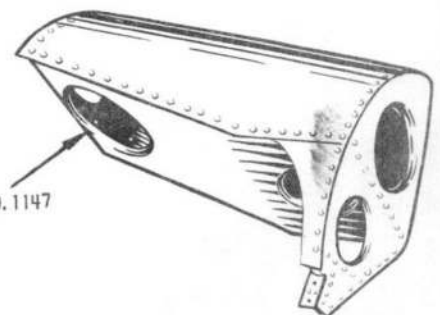
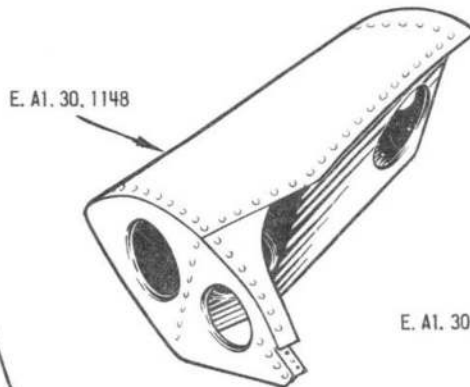
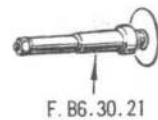
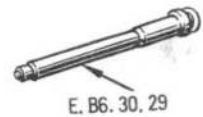
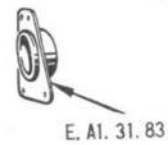
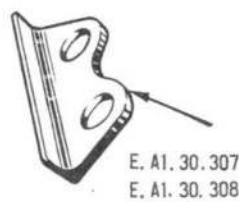
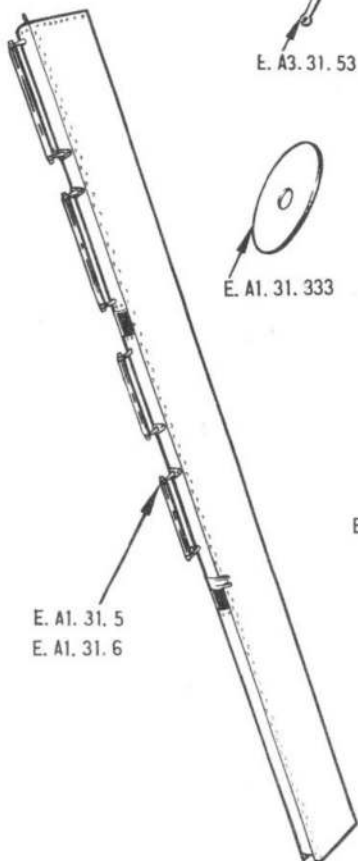
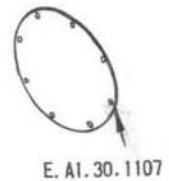
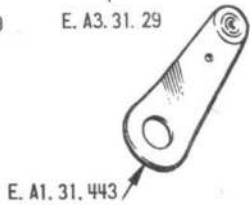
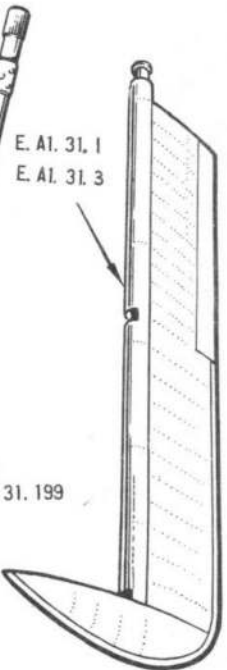
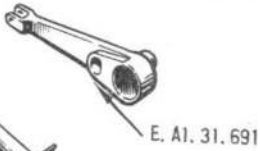
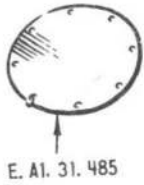
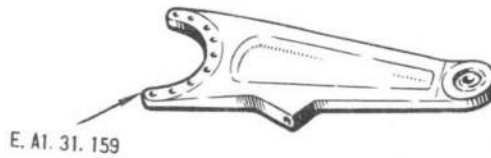

TAILPLANE AND ELEVATORS

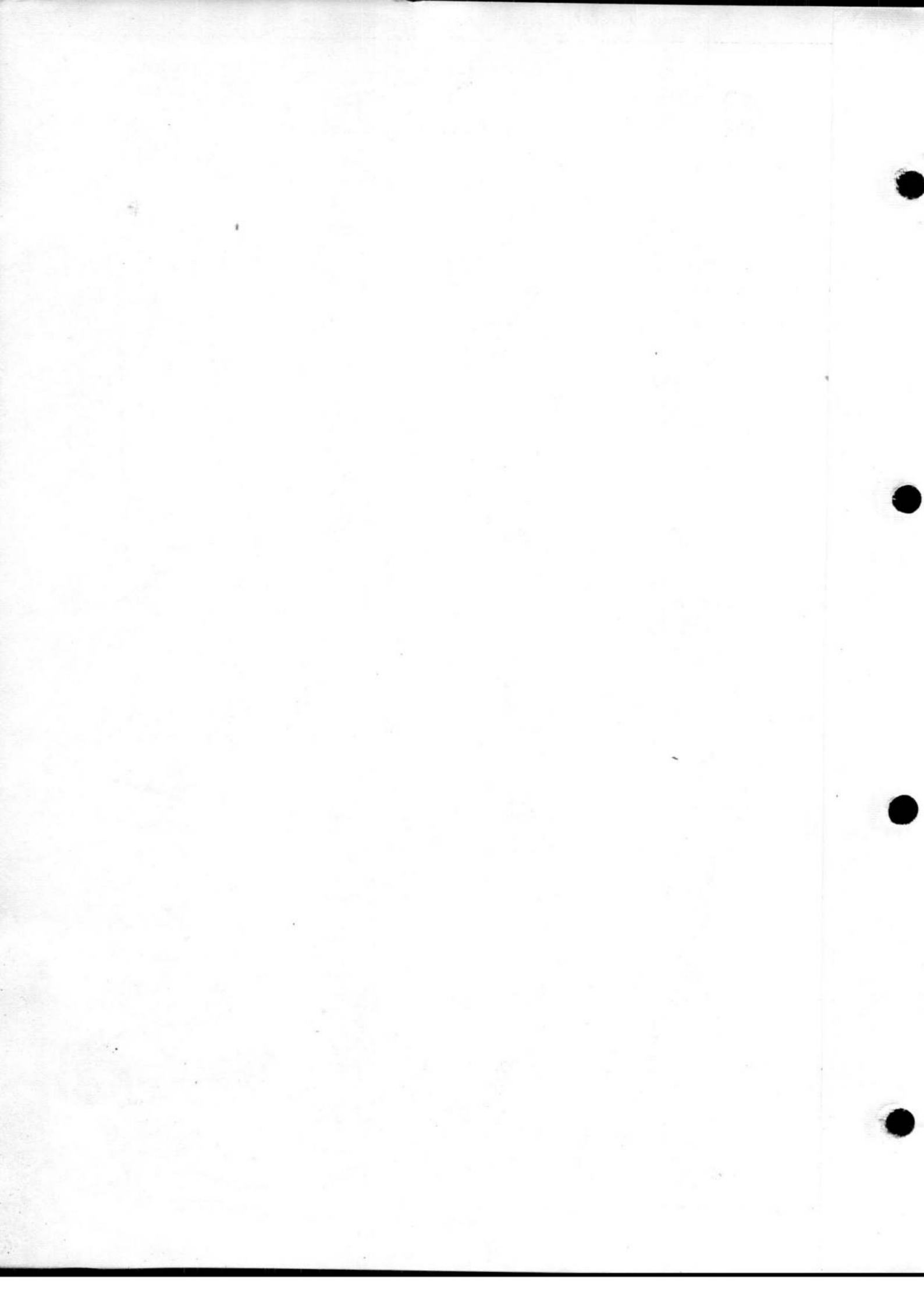

This file was downloaded  
from the RTFM Library.

Link: [www.scottbouch.com/rtfm](http://www.scottbouch.com/rtfm)

Please see site for usage terms,  
and more aircraft documents.

