

**UNDERCARRIAGE
MAIN UNDERCARRIAGE, PORT**

Ref. No.	Part No.	Description	No. off	Matl. Spec.	Cl. of Equip.		Plate No.
					M.R.	L.M.	
		1 2 3 4 5 6					
	E.A1.40.727	MAIN UNDERCARRIAGE, PORT, ASSEMBLY ...	1	—	—		
		Consisting of:—					
	E.A1.40.729	LEG, OLEO (LESS WHEEL, BRAKE UNIT AND FIXED FAIRINGS), GROUP	1	—	—		
		Consisting of:—					
2168	E.A6.40.35	Bolt , special, securing ...	10	S.97	C		
4173	E.A1.40.517	Bolt , special, securing cowl door mechanism to leg (Made from A25/5E, Ref. 28D/1011240)	4	H.T.S.	C/MR		
4174	E.A1.40.519	Bolt , special, securing fixed fairing mounting brackets to leg (Made from A25/5G, Ref. 28D/1011256)	8	H.T.S.	C/MR		
27G/4085	DUNLOP AH.9780	Brake unit (For spares see A.P.4515C, Vol. 3, Part 1, Sect. 2)	1	—	A		U.1
6848	E.B6.20.729	FAIRING, FIXED, ASSEMBLY ...	1	—	B		
		Spares for:—					
3060	E.A3.20.853	FAIRING, FIXED, GROUP ... (Supplied with trim allowance)	1	—	B		U.1
		Spares for:—					
16205	E.A3.20.831	Member , edge ...	1	—	C		
16214	E.A3.20.847	Member , edge ...	1	—	C		
21164	E.A3.20.2869	PANEL, HINGE, ASSEMBLY ...	1	—	C		
		Spares for:—					
	E.A1.20.1679	Hinge (Make from 28N/9486785) ...	1	—	LM		
3025	E.A1.20.1675	Panel , hinge, 16 SWG ...	1	L.72	C		U.1
520	E.A1.40.435	Spring ...	2	Spring Steel	C		
16160	E.A1.20.9367	Stiffener ...	1	—	C		
1413	E.A1.20.6817	Panel , access, picket point ...	1	—	C		U.1
	E.A3.20.1627	Seal , 3/8" dia. 90" long (Make from Ref. 4432) ...	1	Synthetic Rubber	LM		
5970	E.A6.73.93	Washer , special, for flexible pipe, bottom bracket	2	L.72	C		
32314	E.A9.40.23	LEG, SLIDING, AND OLEO HEAD, GROUP (PRE-MOD. 4270)	1	—	A		
34712	E.A9.40.59	LEG, SLIDING AND OLEO HEAD, GROUP (MOD. 4270)	1	—	A		U.1
		Spares for:—					
661	E.A1.40.153	Bush , bearing ...	4	DTD.412	C		U.1
	E.A6.40.3	HEAD, OLEO, GROUP (PRE-MOD. 4270) ...	1	—	—		
	E.A9.40.57	HEAD, OLEO, GROUP (MOD. 4270) ...	1	—	—		
		Spares for:—					
663	E.A1.40.89	Bearing , spherical, sealed, ball joint side stay	1	S.11	C		U.1
664	E.A1.40.101	Bush , bearing ...	1	DTD.412	C		U.1
665	E.A1.40.109	Bush , pivot ...	2	DTD.412	C		U.1
666	E.A1.40.111	Bush , torque link lug ...	2	DTD.412	C		U.1
667	E.A1.40.133	Disc , sealing, stack pipe connection ...	2	L.40	C		
668	E.A1.40.131	Dowel , special, piston ...	2	S.11	C		
	or						
36258	E.A3.03.101	Dowel , piston (first repair) ...	—	—	MR		
	or						
36259	E.A3.03.103	Dowel , piston (second repair) ...	—	—	MR		
21495	E.A1.40.19	Head , oleo, forging (Pre-Mod. 4270) ...	1	DTD.683	A/MR		
42058	E.A9.40.55	Head , oleo, forging (Mod. 4270) ...	1	DTD.5094	A/MR		
669	E.A1.40.103	Hook , "S" shaped, 16 SWG ...	2	M.S. Wire	C		
20656	E.A1.40.127	Pipe , stack, assembly ...	1	—	C/MR		
	E.A6.40.5	PISTON, OPERATING, GROUP ...	1	—	—		
		Consisting of:—					
683	E.A1.40.61	Bolt , special, attachment enclosure orifice plate	3	S.11	C		
1099	EEAS.37/22A	Nipple , 2 BA ...	2	S.11	C		

**UNDERCARRIAGE
MAIN UNDERCARRIAGE, PORT**

Ref. No.	Part No.	Description	No. off	Matl. Spec.	Cl. of Equip.	Plate No.
					M.R. L.M.	
		1 2 3 4 5 6				
670	E.A1.40.647	Piston	1	DTD.197	C	
22528	E.A6.40.33	Plate, orifice enclosure control	1	S.11	C/MR	
672	E.A1.40.651	Ring, piston	1	—	C	U.1
	EEAS.38/3A	Spoke, 2 BA (Make from 28R/6328)	1	S.11	LM	
22227	E.A1.40.117	Strut, piston, main	1	T.4	C/MR	
30A/9140209	†	Wire, locking, 20 SWG	QR	—	C	
673	E.A1.40.679	Plug, pivot bearing, bush retaining	2	L.40	C	
674	E.A1.40.95	Ring, lower, retaining ball joint	1	DTD.124	C	U.1
676	E.A1.40.97	Ring, upper, retaining ball joint	1	DTD.124	C	U.1
678	E.A1.40.155	Ring, sealing, at dowel	2	Synthetic Rubber	C	
679	E.A1.40.625	Screw, special, retaining plug, dowel seal	2	L.40	C	
680	E.A1.40.99	Stud, for retaining rings at ball joint	12	S.11	C	
681	E.A1.40.105	Tube, distance, packing, for locking washer	1	L.40	C	
	H. PRESSURE COMP'TS. LTD.					
28Y/15486	A.58	Valve, charging, hydraulic	1	—	C	
682	E.A1.40.149	Washer, special, locking, 14 SWG	1	DTD.124	C	
	E.A3.40.225	LEG, SLIDING, COMPRESSION, GROUP (PRE-MOD. 4270)	1	—	—	
	E.A9.40.61	LEG, SLIDING, COMPRESSION, GROUP (MOD. 4270)	1	—	—	
		Spares for:—				
26640	E.A3.40.201	Bolt, special, clamp locking (Mod. 2308)	1	S.95 or S.96	C	
683	E.A1.40.61	Bolt, special, stud	6	S.11	C	
684	E.A1.40.161	Bush, bearing, in lug	2	DTD.124	C	U.2
2467	E.A3.40.45	Bush, bearing	1	—	C	U.2
41877	E.A3.40.217	CLAMP, AXLE, GROUP	1	—	C/MR	
		Spares for:—				
21355	E.A3.40.23	Bush	1	L.16	C	
13024	E.A3.40.183	Clamp, axle, body (Mod. 1999)	1	—	C	U.2
1753	E.A3.40.19	Link, towing	1	—	C	
21537	E.A3.40.21	Washer, special, tow link	1	—	C	
14706	E.A3.40.209	Housing, seals (Mod. 2361)	1	L.65	C	
1462	E.A3.40.9	LEG, SLIDING, C/W INTEGRAL AXLE	1	—	A	
		Spares for:—				
6627	E.A3.40.51	Pin, shear	1	S.65	C	
6500	E.A3.40.53	Screw, grub	1	S.95	C	
691	E.A1.40.41	Nut, stop, special	1	S.11	C	
32210	E.A3.40.221	Pin, locking, piston	3	S.97	C	
	E.A3.40.219	Piston, sliding leg	1	DTD.197	—	
693	E.A1.40.175	Plate, orifice	1	S.65	C	
694	E.A1.40.655	Plug, sealing (Pre-Mod. 2361)	1	DTD.683	C	
14701	E.A3.40.203	Plug, sealing (Mod. 2361)	1	DTD.683	C	
695	E.A1.40.677	Plug, pivot bearing, bush retaining	2	L.40	C	
696	E.A1.40.37	Ring, sealing, between bush and retaining washer (Pre-Mod. 2361)	2	Synthetic Rubber	C	
14703	E.A3.40.213	Ring, sealing, seal housing (Mod. 2361)	2	Soft Rubber	C	
12915	E.A1.40.45	Ring, retaining felt washer, 12 SWG	1	M.S.	C	
697	E.A1.40.57	Ring, piston	1	—	C	U.2
14705	E.A3.40.215	Ring, backing (Mod. 2361)	2	Fabric CX18	C	
21221	E.A1.40.635	Ring, distance, between felt washer and sealing rings (Pre-Mod. 2361)	3	DTD.138	C	
14700	E.A3.40.207	Ring, spacer, between sealing and backing rings (Mod. 2361)	1	L.64	C	
12913	E.A1.40.657	Ring, distance, between sealing and backing rings	1	DTD.683	C	

**UNDERCARRIAGE
MAIN UNDERCARRIAGE, PORT**

Ref. No.	Part No.	Description	No. off	Matl. Spec.	Cl. of Equip.		Plate No.
					M.R.	L.M.	
		1 2 3 4 5 6					
21354	E.A1.40.659	Ring, shock absorber, stop	1	DTD.683	C		
698	E.A1.40.661	Ring, sealing (Pre-Mod. 2361)	1	Synthetic Rubber	C		
14702	E.A3.40.205	Ring, sealing (Mod. 2361)	1	Soft Rubber	C		
14704	E.A3.40.211	Ring, sealing, seal housing (Mod. 2361)	1	Soft Rubber	C		
700	E.A1.40.167	Screw, grub, stop nut, locking	1	S.1	C		
701	E.A1.40.39	Washer, fibre, between retaining ring and lock nut	1	BS.216	C		
702	E.A1.40.43	Washer, packing, $\frac{3}{16}$ " thick	1	Hard Felt	C		
3631	E.A1.40.27	Link, torque toggle	1	DTD.683	C		U.2
3632	E.A1.40.28	Link, torque toggle	1	DTD.683	C		U.2
703	E.A1.40.67	Pin, bearing, bottom toggle link	1	S.11	C		U.2
704	E.A1.40.69	Pin, bearing, top toggle link	1	S.11	C		U.2
1500	E.A3.40.27	Pin, bearing, toggle joint	1	S.97	C		U.2
707	E.A1.40.77	Screw, special, retaining bearing pin	2	S.11	C		
708	E.A1.40.139	Screw, grub, special, locking top and bottom bearing pins	2	M.S.	C		
709	E.A1.40.619	Shim, bearing pin sleeve	2	L.A.	C		
710	E.A1.40.71	Sleeve, bearing, for toggle link	1	S.11	C		U.2
711	E.A1.40.73	Sleeve, bearing, for toggle link	1	S.11	C		U.2
712	E.A1.40.137	Tab, locking, 16 SWG	1	M.S.	C		
713	E.A1.40.75	Washer, special, bearing thrust	2	DTD.412	C		
714	E.A1.40.79	Washer, special, locking, bearing pin retaining screw, 16 SWG	2	M.S.	C		
715	E.A1.40.83	Washer, spacing, at toggle joint between link bearings	1	S.11	C		
1514	E.A3.40.29	Washer, special, at toggle joint	1	S.96	C		
1515	E.A3.40.31	Washer, special, at toggle joint	1	S.96	C		
718	E.A1.40.147	Washer, special, bearing thrust	2	DTD.412	C		
521	E.A1.40.467	LEVER COWL DOOR MECHANISM, GROUP ...	1	—	C		
		Spares for:—					
522	E.A1.40.465	Bush, bearing	2	L.40	C		
	E.A1.40.529	Lever, operating	1	—	—		
	DUNLOP						
27G/2485	AHM.2572	Pipe, feed, for maxaret unit	1	—	C		
	DUNLOP						
27G/2486	AHM.2574	Pipe, feed, for maxaret unit	1	—	C		
	DUNLOP						
27A/3153	DT.1606	Tube, 43" x 12"5 x 21"	1	—	A		
	DUNLOP						
27A/3152	DF.1621	Tyre, outer, 43" x 12"5 x 21"	1	—	A		
	FIRESTONE ZA.101						
	or						
	DUNLOP						
27A/4655	DR.1623						
	GOODYEAR GA.1266						
	FIRESTONE ZA.303						
	DUNLOP						
27G/2382	AC.11516	Unit, maxaret, automatic brake control	1	—	A		U.2
2169	E.A3.40.43	Washer, special	10	DTD.124A	C		
	DUNLOP						
27A/4217	AH.51337	Wheel, undercarriage (For spares see A.P.1086, Part 11) (Mod. 2615)	1	—	A		
30A/2296	†	Wire, locking, 20 SWG	QR	—	C		

End of 199-40-5

**UNDERCARRIAGE
MAIN UNDERCARRIAGE, PORT**

Ref. No.	Part No.	Description	No. off	Matl. Spec.	Cl. of Equip.		Plate No.
					M.R.	L.M.	
		1 2 3 4 5 6					
523	E.A1.40.29	STAY, SIDE, UNDERCARRIAGE, GROUP (PRE-MOD. 3585)	1	—	A		
		Spares for:—					
525	E.A1.40.195	Bolt, special, hook	1	S.65 or 81	C		
526	E.A1.40.197	Bolt, special, connecting stay and link	1	S.65 or 81	C		
527	E.A1.40.203	Bolt, special, for roller assembly locking gear	1	S.11	C		
528	E.A1.40.221	Bolt, special, connecting undercarriage operating jack	1	S.65 or 81	C		
529	E.A1.40.239	Bolt, stop, special link stay	1	S.65 or 81	C		
530	E.A1.40.405	Bolt, special, sequence valve operating	1	S.11	C		
7112	E.A1.40.229	Bracket, solenoid operating stud	1	S.11	C/MR		U.2
7114	E.A1.40.403	Bracket, sequence valve operating stud	1	L.40	C/MR		U.2
531	E.A1.40.199	LEVER, UNDERCARRIAGE LOCK, GROUP ...	1	—	C		U.2
		Consisting of:—					
532	E.A1.40.213	Bush	1	DTD.197	C		
	E.A1.40.201	Lever	1	S.11	—		
533	E.A1.40.200	LEVER, UNDERCARRIAGE LOCK, GROUP ...	1	—	C		U.2
		Consisting of:—					
532	E.A1.40.213	Bush	1	DTD.197	C		
	E.A1.40.202	Lever	1	S.11	—		
13168	E.A3.40.191	LEVER, UNDERCARRIAGE "DOWN" MICRO SWITCH, ASSEMBLY (MOD. 2151)	1	—	C		
		Spares for:—					
179	E.A1.40.569	Screw, tappet	1	S.11	C		
6472	E.A1.40.225	LINK, SIDE STAY, GROUP	1	—	B/MR		
		Spares for:—					
536	E.A1.40.227	Bush, bearing	8	DTD.197	C		
26667	E.A3.40.193	Nut, special, slotted, for undercarriage operating jack bolt (Make from A27/JS) (Mod. 2151)	1	M.T.S.	C		
12916	E.A1.40.347	Nut, special, slotted, for link and link stay connecting bolt (Make from A27/WS, Ref. 28M/13276)	1	M.S.	C		
	E.A1.40.351	Nut, special, slotted, for hook catch pin bolt (Make from A27/QS, Ref. 28M/13145)	1	M.S.	—		
	E.A1.40.349	Nut, special, slotted, for undercarriage roller locking bolt (Make from A27/JS, Ref. 28M/1011476)	1	M.S.	—		
537	E.A1.40.353	Nut, special, lock, for stay link stop bolt	1	S.11	C		
13184	E.A3.40.199	Plate	1	DTD.124	C		
538	E.A1.40.223	Plug, adaptor, for Tecaletit grease nipple in link and stay connecting bolt	1	L.40	C		
539	E.A1.40.205	Roller, stop lever, assembly	1	—	C		U.2
7113	E.A1.40.233	Sleeve, operating spring for undercarriage lock stop	1	DTD.197	C/MR		U.2
540	E.A1.40.237	Spring, compression, at lock stop	1	Spring Steel Wire	C		U.2
38706	E.A1.40.31	Stay, side	1	DTD.683	B/MR		
541	E.A1.40.235	Stop, undercarriage lock	1	S.11	C		U.2
542	E.A1.40.217	Tube, distance, for undercarriage "down" switch operating bracket	1	L.40	C		
543	E.A1.40.219	Tube, distance, for undercarriage "down" switch operating bracket	1	L.40	C		
544	E.A1.40.291	Washer, tab, at undercarriage hook catch bolt. 20 SWG	1	S.3	C		

7/12/11
Pages 1789 to 1808 not issued

UNDERCARRIAGE
MAIN UNDERCARRIAGE, STARBOARD

Ref. No.	Part No.	Description	No. off	Matl. Spec.	Cl. of Equip.	Plate No.
					M.R. L.M.	
		1 2 3 4 5 6				
	E.A1.40.728	MAIN UNDERCARRIAGE, STARBOARD, ASSEMBLY Consisting of:—	1	—	—	
	E.A1.40.730	LEG, OLEO (LESS WHEEL, BRAKE UNIT AND FIXED FAIRING), GROUP Consisting of:—	1	—	—	
2168	E.A6.40.35	Bolt , special, securing	10	S.97	C	
4173	E.A1.40.517	Bolt , special, securing cowl door mechanism to leg (Make from A25/5E, Ref. 28D/1011240)	4	H.T.S.	C/MR	
4174	E.A1.40.519	Bolt , special, securing, fixed fairing mounting bracket to leg (Make from A25/5G, Ref. 28D/1011256)	8	H.T.S.	C/MR	
27G/4086	DUNLOP AH.9781	Brake unit (For spares see A.P.4515C, Vol. 3, Pt. 1, Sect. 2)	1	—	A	U.1
6849	E.B6.20.730	FAIRING, FIXED, ASSEMBLY Spares for:—	1	—	B	
3061	E.A3.20.854	FAIRING, FIXED, GROUP (Supplied with trim allowance) Spares for:—	1	—	B	U.1
16206	E.A3.20.832	Member , edge	1	—	C	
16215	E.A3.20.848	Member , edge	1	—	C	
21721	E.A3.20.2870	PANEL, HINGE, ASSEMBLY Spares for:—	1	—	C	
3026	E.A1.20.1679	Hinge (Make from 28N/9486785)	1	—	LM	
1887	E.A1.40.436	Panel , hinge, 16 SWG	1	L.72	C	U.1
16161	E.A1.20.9368	Spring	2	Spring Steel	C	
1413	E.A1.20.6817	Stiffener	1	—	C	
	E.A3.20.1627	Panel , access	1	—	C	U.1
5970	E.A6.73.93	Seal , 3/4" dia., 90" long (Make from Ref. 4432)	1	Synthetic Rubber	LM	
32315	E.A9.40.24	Washer , special, for flexible pipe, bottom bracket	2	L.73	C	
34713	E.A9.40.60	LEG, SLIDING AND OLEO HEAD, GROUP (PRE-MOD. 4270)	1	—	A	U.1
660	E.A1.40.639	LEG, SLIDING AND OLEO HEAD, GROUP (MOD. 4270) Spares for:—	1	—	A	
661	E.A1.40.153	Bracket , angle, micro switch mounting, 20 SWG	1	L.72	C	
662	E.A1.40.671	Bush , bearing	4	DTD.412	C	U.1
	E.A6.40.4	Finger , operating, micro switch	1	—	C	
	E.A9.40.58	HEAD, OLEO, GROUP (PRE-MOD. 4270)	1	—	—	
		HEAD, OLEO, GROUP (MOD. 4270) Spares for:—	1	—	—	
663	E.A1.40.89	Bearing , spherical seated ball joint, side stay	1	S.11	C	U.1
664	E.A1.40.101	Bush , bearing	1	DTD.412	C	U.1
665	E.A1.40.109	Bush , pivot	2	DTD.412	C	U.1
666	E.A1.40.111	Bush , torque, link lug	2	DTD.412	C	U.1
667	E.A1.40.133	Disc , sealing, stack pipe connection	2	L.40	C	
668	E.A1.40.131	Dowel , special, piston	2	S.11	C	
36258	E.A3.03.101	Dowel , piston (first repair)	—	—	MR	
36259	E.A3.03.103	Dowel , piston (second repair)	—	—	MR	
21482	E.A1.40.20	Head , oleo, forging (Pre-Mod. 4270)	1	DTD.683	A/MR	
42059	E.A9.40.56	Head , oleo, forging (Mod. 4270)	1	DTD.5094	A/MR	
669	E.A1.40.103	Hook , "S" shaped, 16 SWG	2	M.S. Wire	C	
20656	E.A1.40.127	Pipe , stack, assembly	1	—	C/MR	

UNDERCARRIAGE
MAIN UNDERCARRIAGE, STARBOARD

Ref. No.	Part No.	1	2	3	4	5	6	Description	No. off	Matl. Spec.	Cl. of Equip.		Plate No.
											M.R.	L.M.	
	E.A6.40.6							PISTON, OPERATING, GROUP	1	—	—		
								Consisting of:—					
683	E.A1.40.61							Bolt , special, attachment enclosure orifice plate	3	S.11	C		
1099	EEAS.37/22A							Nipple , 2 BA	2	S.11	C		
670	E.A1.40.647							Piston	1	DTD.197	C		
22528	E.A6.40.33							Plate , orifice enclosure control	1	S.11	C		
672	E.A1.40.651							Ring , piston	1	—	C	U.1	
	EEAS.38/3A							Spoke , 2 BA (Made from 28R/6328)	1	S.11	LM		
12914	E.A1.40.118							Strut , piston, main	1	T.4	C/MR		
30A/9140209	†							Wire , locking, 20 SWG	QR	—	C		
673	E.A1.40.679							Plug , pivot, bearing, bush retaining	2	L.40	C		
675	E.A1.40.96							Ring , lower, retaining ball joint	1	DTD.124	C	U.1	
677	E.A1.40.98							Ring , upper, retaining ball joint	1	DTD.124	C	U.1	
678	E.A1.40.155							Ring , sealing, at dowel	2	Synthetic Rubber	C		
679	E.A1.40.625							Screw , special, retaining plug dowel seal	2	L.40	C		
680	E.A1.40.99							Stud , for retaining rings at ball joint	12	S.11	C		
681	E.A1.40.105							Tube , distance, packing, for locking washer	1	L.40	C		
	H. PRESSURE COMP'TS. LTD.												
28Y/15486	A.58							Valve , charging, hydraulic	1	—	C		
682	E.A1.40.149							Washer , special, locking, 14 SWG	1	DTD.124	C		
	E.A3.40.226							LEG, SLIDING, COMPRESSION, GROUP (PRE-MOD. 4270)	1	—	—		
	E.A9.40.62							LEG, SLIDING, COMPRESSION, GROUP Spares for:—	1	—	—		
26640	E.A3.40.201							Bolt , special, clamp locking (Mod. 2308)	1	S.95 or S.96	C		
683	E.A1.40.61							Bolt , special, stud	6	S.11	C		
684	E.A1.40.161							Bush , bearing, in lug	2	DTD.124	C	U.2	
2467	E.A3.40.45							Bush , bearing	1	—	C	U.2	
41877	E.A3.40.217							CLAMP, AXLE, GROUP Spares for:—	1	—	C/MR		
21355	E.A3.40.23							Bush	1	L.16	C		
13024	E.A3.40.183							Clamp , axle body (Mod. 1999)	1	—	C		
1753	E.A3.40.19							Link , towing	1	—	C		
21537	E.A3.40.21							Washer , special, tow link	1	—	C		
14706	E.A3.40.209							Housing , seal (Mod. 2361)	1	L.65	C		
1463	E.A3.40.10							LEG, SLIDING, C/W INTEGRAL AXLE Spares for:—	1	—	A		
6627	E.A3.40.51							Pin , shear	1	S.65	C		
6500	E.A3.40.53							Screw , grub	1	S.95	C		
691	E.A1.40.41							Nut , stop, special	1	S.11	C		
32210	E.A3.40.221							Pin , locking piston	3	S.97	C		
	E.A3.40.219							Piston , sliding leg	1	DTD.197	—		
693	E.A1.40.175							Plate , orifice	1	S.65	C		
694	E.A1.40.655							Plug , sealing (Pre-Mod. 2361)	1	DTD.683	C		
14701	E.A3.40.203							Plug , sealing (Mod. 2361)	1	DTD.683	C		
695	E.A1.40.677							Plug , pivot, bearing bush retaining	2	L.40	C		
696	E.A1.40.37							Ring , sealing, between bush and retaining washer (Pre-Mod. 2361)	2	Synthetic Rubber	C		
14703	E.A3.40.213							Ring , sealing, seal housing (Mod. 2361)	2	Soft Rubber	C		
12915	E.A1.40.45							Ring , retaining, felt washer, 12 SWG	1	M.S.	C		
697	E.A1.40.57							Ring , piston	1	—	C	U.2	
14705	E.A3.40.215							Ring , backing (Mod. 2361)	2	Fabric CX18	C		

**UNDERCARRIAGE
MAIN UNDERCARRIAGE, STARBOARD**

Ref. No.	Part No.	Description	No. off	Matl. Spec.	Cl. of Equip.		Plate No.
					M.R.	L.M.	
		1 2 3 4 5 6					
21221	E.A1.40.635	Ring, distance, between felt washer and sealing rings (Pre-Mod. 2361)	3	DTD.138	C		
✓ 14700	E.A3.40.207	Ring, distance, between sealing and backing rings (Mod. 2361)	1	L.64	C		
✓ 12913	E.A1.40.657	Ring, spacer, between sealing rings	1	DTD.683	C		
✓ 21354	E.A1.40.659	Ring, shock absorber stop	1	DTD.683	C		
698	E.A1.40.661	Ring, sealing (Pre-Mod. 2361)	1	Synthetic Rubber	C		
✓ 14702	E.A3.40.205	Ring, sealing (Mod. 2361)	1	Soft Rubber	C		
✓ 14704	E.A3.40.211	Ring, sealing, seal housing (Mod. 2361) ...	1	Soft Rubber	C		
✓ 700	E.A1.40.167	Screw, grub, stop nut locking	1	S.1	C		
✓ 701	E.A1.40.39	Washer, fibre, between retaining ring and stop nut	1	BS.216	C		
✓ 702	E.A1.40.43	Washer, packing, $\frac{3}{8}$ " thick	1	Hard Felt	C		
✓ 3631	E.A1.40.27	Link, torque, toggle	1	DTD.683	C		U.2
✓ 3632	E.A1.40.28	Link, torque, toggle	1	DTD.683	C		U.2
✓ 703	E.A1.40.67	Pin, bearing, bottom toggle link	1	S.11	C		U.2
✓ 704	E.A1.40.69	Pin, bearing, top toggle link	1	S.11	C		U.2
1500	E.A3.40.27	Pin, bearing, toggle joint	1	S.97	C		U.2
706	E.A1.40.335	Plate, packing, Burgess micro switch mounting	1	L.A.	C		
✓ 707	E.A1.40.77	Screw, special, retaining bearing pin	2	S.11	C		
✓ 708	E.A1.40.139	Screw, grub, special, locking top and bottom bearing pins	2	S.11	C		
✓ 709	E.A1.40.619	Shim, bearing pin sleeve	2	L.40	C		
✓ 710	E.A1.40.71	Sleeve, bearing, for toggle link	1	S.11	C		U.2
✓ 711	E.A1.40.73	Sleeve, bearing, for toggle link	1	S.11	C		U.2
✓ 712	E.A1.40.137	Tab, locking, 16 SWG	1	M.S.	C		
✓ 713	E.A1.40.75	Washer, special, bearing thrust	2	DTD.412	C		
✓ 714	E.A1.40.79	Washer, special, locking, bearing pin retaining screw	2	M.S.	C		
✓ 715	E.A1.40.83	Washer, spacing, at toggle joint between link bearings	1	S.11	C		
✓ 1514	E.A3.40.29	Washer, special, at toggle joint	1	S.96	C		
✓ 718	E.A1.40.147	Washer, special, bearing thrust	2	DTD.412	C		
✓ 1515	E.A3.40.31	Washer, special, at toggle joint	1	S.96	C		
✓ 521	E.A1.40.467	LEVER, COWL DOOR MECHANISM, GROUP	1	—	C		
		Spares for:—					
✓ 522	E.A1.40.465	Bush, bearing	2	L.40	C		
	E.A1.40.529	Lever, operating	1	—	—		
	DUNLOP						
27G/2487	AHM.2576	Pipe, feed, for maxaret unit	1	—	C		
	DUNLOP						
27G/2488	AHM.2578	Pipe, feed, for maxaret unit	1	—	C		
	DUNLOP						
27A/3153	DT.1606	Tube, 43" x 12"5 x 21"	1	—	A		
27A/3152	DUNLOP DF.1621	Tyre, outer, 43" x 12"5 x 21"	1	—	A		
	FIRESTONE						
	ZA.101						
	or						
27A/4655	DUNLOP DR.1623						
	GOODYEAR						
	GA.1266						
	FIRESTONE						
	ZA.303						

**UNDERCARRIAGE
MAIN UNDERCARRIAGE, STARBOARD**

Ref. No.	Part No.	Description	No. off	Matl. Spec.	Cl. of Equip.	Plate No.
					M.R. L.M.	
		1 2 3 4 5 6				
27G/2381	DUNLOP	Unit, maxaret, automatic brake control	1	—	A	U.2
2169	AC.11514 E.A3.40.43	Washer, special	10	DTD.124A	C	
27A/4217	DUNLOP AH.51337	Wheel, undercarriage (For spares see A.P.1086, Pt. 11) (Mod. 2615)	1	—	A	
30A/2296	†	Wire, locking, 20 SWG	QR	—	C	
524	E.A1.40.30	STAY, SIDE, UNDERCARRIAGE, GROUP (PRE- MOD. 3585) Spares for this group are identical with those for group Ref. No. 523 on page 1784 except for the following deletions and additions:— Delete:—	1	—	A	
7114	E.A1.40.403	Bracket, sequence valve operating stud	1	L.40	C/MR	U.2
13168	E.A3.40.191	LEVER, UNDERCARRIAGE "DOWN MICRO SWITCH, ASSEMBLY (MOD. 2151)	1	—	C	
38706	E.A1.40.31	Stay, side Add:—	1	DTD.683	B/MR	
32721	E.A1.40.404	Bracket, sequence valve operating stud	1	L.40	C	U.2
13169	E.A3.40.192	LEVER, UNDERCARRIAGE "DOWN" MICRO SWITCH, ASSEMBLY (MOD. 2151)	1	—	C	
38707	E.A1.40.32	Stay, side	1	DTD.683	B/MR	
34173	E.A9.40.44	STAY, SIDE, UNDERCARRIAGE, GROUP (MOD. 3585) Spares for this group are identical with those for group Pt. No. E.A1.40.30, except for the following deletion and addition Delete:—	1	—	A	
38707	E.A1.40.32	Stay, side Add:—	1	DTD.683	B/MR	
40651	E.A9.40.40	Stay, side	1	DTD.5024	B/MR	

3 A2/11
Pages 1815 to 1834 not issued



**UNDERCARRIAGE
MAIN UNDERCARRIAGE, PORT AND STARBOARD**

Ref. No.	Part No.	Description						No. off	Matl. Spec.	Cl. of Equip.	Plate No.
		1	2	3	4	5	6			M.R. L.M.	
SUMMARY OF STOCK ITEMS USED ON MAIN UNDERCARRIAGE, PORT AND STARBOARD, ASSEMBLY											
28D/9140638	A25/4B	Bolt, 4 BA, hex. head, "8 long		C	
28D/1010142	A25/9B	Bolt, 4 BA, hex. head, 1"3 long		C	
28D/9436920	A25/1C	Bolt, 2 BA, hex. head, "55 long		C	
28D/9133011	A25/2C	Bolt, 2 BA, hex. head, "65 long		C	
28D/9133012	A25/3C	Bolt, 2 BA, hex. head, "75 long		C	
28D/9133013	A25/5C	Bolt, 2 BA, hex. head, "95 long		C	
28D/7002428	A25/6C	Bolt, 2 BA, hex. head, 1"05 long		C	
28D/1011019	A25/8C	Bolt, 2 BA, hex. head, 1"25 long		C	
28D/9140644	A25/9C	Bolt, 2 BA, hex. head, 1"35 long		C	
28D/9453970	A25/15C	Bolt, 2 BA, hex. head, 1"9 long		C	
28D/12824	A25/4J	Bolt, 3/8" BSF, hex. head, 1"05 long		C	
28D/1011299	A25/6J	Bolt, 3/8" BSF, hex. head, 1"25 long		C	
28D/1011310	A25/8L	Bolt, 7/16" BSF, hex. head, 1"5 long		C	
28D/13715	A25/15L	Bolt, 7/16" BSF, hex. head, 2"2 long		C	
28D/13196	A25/18L	Bolt, 7/16" BSF, hex. head, 2"5 long		C	
28D/8300	AS.1242/1B	Bolt, 4 BA, c'sk. head, "45 long		C	
28D/11890	AS.1246/5C	Bolt, 2 BA, round head, "9 long		C	
28N/9156370	SP.21	Nipple, lubricating		C	
28M/1011001	A24/NS	Nut, 1/2" BSF, slotted		C	
28M/9403519	A27/BP	Nut, 4 BA, plain		C	
28M/9403520	A27/CP	Nut, 2 BA, plain		C	
28M/1011470	A27/GT	Nut, 1/8" BSF, thin		C	
28M/1011476	A27/JS	Nut, 3/8" BSF, slotted		C	
28M/13259	A27/NS	Nut, 1/2" BSF, slotted		C	
28M/13590	A27/SS	Nut, 3/4" BSF, slotted		C	
128M/10288	AGS.2001/C/1	Nut, stiff, 2 BA		C	
28M/12050	AGS.2007/C/3	Nut, plate, 2 BA		C	
28P/9429619	SP.9/C5	Pin, split, 1/16" dia. x 5/8" long		C	
28P/1007741	SP.9/C8	Pin, split, 1/16" dia. x 1" long		C	
28P/1011034	SP.9/E12	Pin, split, 3/32" dia. x 1 1/4" long		C	
28P/9429653	SP.9/G12	Pin, split, 1/8" dia. x 1 1/2" long		C	
28P/1011082	SP.9/G16	Pin, split, 1/8" dia. x 2" long		C	
28P/12366	SP.9/K20	Pin, split, 3/16" dia. x 2 1/2" long		C	
28S/1200034	A31/B16	Screw, 4 BA, cheese head, 1/2" long		C	
28S/9437020	A31/C12	Screw, 2 BA, cheese head, 3/8" long		C	
28S/9435713	A31/C20	Screw, 2 BA, cheese head, 5/8" long		C	
28W/9419466	SP.13/J	Washer, 3/8" BSF, plain		C	
28W/9419474	SP.15/B	Washer, 4 BA, plain		C	
28W/9419475	SP.15/C	Washer, 2 BA, plain		C	
28W/9416642	SP.47/B	Washer, 4 BA, spring		C	
28W/9416643	SP.47/C	Washer, 2 BA, spring		C	
28W/9416645	SP.47/G	Washer, 1/8" BSF, spring		C	

Restricted

Ref. No.	Part No.	Description						No. off	Matl. Spec.	Cl. of Equip.	Plate No.
		1	2	3	4	5	6			M.R. L.M.	

NOSEWHEEL

Ref. No.	Part No.	Description	off	Matl. Spec.	Cl. of Equip.		Plate No.
					M.R.	L.M.	
	E.A9.40.1	NOSEWHEEL, ASSEMBLY	1	—	—		
		Spares for:—					
22055	E.A9.40.15	BLOCK , flexible hose support	2	LFS.21	C		
161	E.A1.40.451	BOLT , special, c/w spoke and nut, radius rod, strut bearing	1	—	C		
22373	E.A9.40.19	BOLT , special, connecting operating jack to under-carriage locking lever (Pre-Mod. 2704) ...	1	S.96	C		
32172	E.A9.40.21	BOLT , special, connecting operating jack to under-carriage locking lever (Mod. 2704)	1	S.96	C		
163	E.A1.40.491	BOLT , special, nosewheel door "up" lock	1	S.11	C		
164	E.A1.40.493	BOLT , special, nosewheel door "up" catch	1	S.11	C		
4507	E.A3.40.139	BOLT , special, jack attachment to crosshead ...	1	S.11	C		
166	E.A1.40.581	BOLT , special, fulcrum, undercarriage door actuating sequence valve	1	S.11	C		
167	E.A1.40.593	BOLT , special, connecting door operating strut to hydraulic jack	2	S.11	C		
168	E.A1.40.595	BOLT , special, attachment, door actuating lock to crosshead	2	S.11	C		
169	E.A1.40.605	BOLT , special, hydraulic jack anchor	1	S.65	C		
22056	E.A9.40.11	BOLT , special, nose undercarriage jack hinge ...	1	S.95	C		
3753	E.A1.40.617	BOLT , special, adjusting undercarriage door cross-head	1	H.T.S.	C		
170	E.A1.40.683	BOLT , special, connecting stay link and under-carriage unit	1	S.11	C		
12023	E.A3.40.159	BRACKET, UNDERCARRIAGE "UP" HOOK, GROUP	1	—	C		
		Consisting of:—					
	E.A1.40.385	BEAM, BRACKET LOCKING HOOK, GROUP	1	—	—		
		Spares for:—					
20845	E.A1.40.369	LUG	1	L.40	C/MR		
25628	E.A1.40.377	PLATE , locking	1	L.72	C		
171	E.A1.40.371	BOLT , special, pivot for hook	1	S.11	—		
12024	E.A3.40.151	BOLT , special, for buffer assembly	2	—	C		
22251	E.A1.40.373	BRACKET , hook suspension	1	S.11	C		
12025	E.A3.40.143	HOOK, UNDERCARRIAGE "UP" LATCH, GROUP	1	—	C		
		Consisting of:—					
13109	E.A3.40.147	BOLT , special	1	DTD.126A	C		
	E.A1.40.393	BUSH	1	DTD.197	—		
	E.A3.40.145	HOOK , "up" catch	1	H.T.S.	—		
20846	E.A1.40.389	SCREW , special, hook stop	1	S.11	C/MR		
	E.A1.40.381	TUBE , distance, for beam mounting bolts ...	8	T.4	—		
174	E.A1.40.399	WASHER , special, laminium, at buffer bolts ...	3	LA	C		
22057	E.A9.40.13	CLIP ; flexible hose, support block	2	L.72	C		
4694	E.A3.40.93	CROSSHEAD, NOSEWHEEL DOORS, C/W VALVE TRIP, ASSEMBLY	—	—	B		
		Spares for:—					
5514	E.A3.40.97	PIN , roller, top	1	S.11	C		
12926	E.A3.40.181	PIN , roller, bottom	1	S.11	C		
178	E.A1.40.553	ROLLER , guide	2	DTD.683	C		
5515	E.A1.40.561	VALVE , trip	1	—	C		

NOSEWHEEL

Ref. No.	Part No.	Description	off	Matl. Spec.	Cl. of Equip.	Plate No.
					M.R. L.M.	
		1 2 3 4 5 6				
3751	E.A1.40.567	LEVER, UNDERCARRIAGE SEQUENCE VALVE, GROUP	1	—	B/MR	
		Spares for:—				
179	E.A1.40.569	TAPPET , valve screw	1	S.11	C	
3754	E.A1.40.703	LEVER BRACKET, UNDERCARRIAGE SEQUENCE VALVE, GROUP	1	—	B/MR	
		Spares for:—				
13182	E.A1.40.709	BOLT , special, fulcrum	1	S.11	C	
	E.A1.40.573	LEVER , sequence valve operating	1	DTD.683	—	
179	E.A1.40.569	TAPPET , valve screw	1	S.11	C	
	E.A1.40.711	WASHER , special, fulcrum bolt	2	L.40	—	
39181	E.A9.40.35	LEVER , micro switch operating, undercarriage door front latch (Mod. 2183)	1	—	C	
		Attaching parts for E.A9.40.35:—				
28D/9140647	A25/14C	Bolt, 2 BA	1	—	C	
28M/10288	AGS.2001/C/1	Nut, 2 BA	1	—	C	
3755	E.A1.40.731	Piece, distance	1	—	C	
4141	E.A1.45.989	Shim	2	—	C	
	AS.2811/7/023	Spacer	2	L.62	LM	
180	E.A1.40.531	LINK, DOOR OPERATING, GROUP	2	—	C	
		Spares for:—				
4778	E.A1.40.535	EYE BOLT , assembly	2	—	C	
33793	E.A1.40.541	NUT , special (Make from 28M/6896, A16Y/QT)	2	M.S.	C	
8987	E.A3.40.169	MUDGUARD, NOSEWHEEL, ASSEMBLY	—	—	B	
		Consisting of:—				
28D/9133012	A25/3C	BOLT , 2 BA	12	H.T.S.	C	
28D/1007974	AS.1242/1/2C	BOLT , 2 BA	3	H.T.S.	C	
28D/1013177	AS.1242/2E	BOLT , 1/4" BSF	9	H.T.S.	C	
5503	E.A3.40.133	FLAP , rubber, nosewheel mudguard	1	Shore 40	C	
5504	E.A3.40.127	MUDGUARD , nosewheel	1	L.72	C	
28M/1006473	A27/CT	NUT , 2 BA	12	—	C	
28M/1007403	A27/ET	NUT , 1/4" BSF	6	—	C	
5505	E.A3.40.131	NUT , special, shouldered, 1/4" BSF	3	S.95	C	
5506	E.A3.40.137	NUT , special, shouldered, 2 BA	3	S.95	C	
6948	E.A3.40.165	STAY , mudguard	1	—	C	
6949	E.A3.40.167	STAY , end, mudguard attachment	3	DTD.683	C	
20930	E.A3.40.135	STRIP , backing	1	L.72	C	
28W/9419475	SP.15/C	WASHER	12	—	C	
8988	E.A3.40.170	MUDGUARD, NOSEWHEEL, ASSEMBLY	—	—	B	
		Spares for this assembly are identical with those for assembly Part No. E.A3.40.169				
28N/9156370	SP.21	NIPPLE , lubricating	1	—	C	
181	E.A1.40.449	PIN , strut, pivot radius rod bearing	1	S.65	C	
3688	E.A6.40.37	ROD, RADIUS, GROUP	1	—	A	
		Consisting of:—				
4447	E.A1.40.321	BOLT , special, bearing, for undercarriage "up" micro switch operating finger	1	DTD.126A	C	
184	E.A1.40.681	BOLT , special, connecting, radius rod and stay link	1	S.11	C	
5126	E.A3.40.77	BRACKET , micro switch	1	L.72	C	

NOSEWHEEL

Ref. No.	Part No.	Description	No. off	Matl. Spec.	Cl. of Equip.	Plate No.
					M.R. L.M.	
		1 2 3 4 5 6				
3656	E.A3.40.65	BUSH , spring plunger	1	DTD.197	C	
28N/2001540	AGS.2031/4	CIRCLIP , "Seegar", external, 1/8" dia. for under-carriage lock latch spindle	2	—	C	
186	E.A1.40.621	DOWEL , special	2	S.11	C	
1893	E.A6.40.21	END, PLUG, RADIUS ROD, GROUP	1	—	B	
		Spares for:—				
187	E.A1.40.363	BUSH , bearing	1	DTD.197	C	
28N/9156370	SP.21	NIPPLE , lubricating	1	—	C	
4937	E.A1.40.311	FINGER , operating undercarriage "up" micro switch	1	L.40	C	
1894	E.A6.40.29	FORK , strut end	1	DTD.683	C	
3655	E.A3.40.73	HOUSING , spring locking plunger	1	L.40	C	
41255	E.A9.40.49	LEVER, LOCKING, NOSEWHEEL UNDER-CARRIAGE, GROUP (MOD. 3487)	1	—	B	
		Spares for:—				
190	E.A1.40.337	BUSH , bearing	2	DTD.197	C	
28N/9156370	SP.21	NIPPLE , lubricating	1	—	C	
192	E.A1.40.339	ROLLER , assembly	1	—	C	
		Attaching parts for E.A1.40.339:—				
188	E.A1.40.343	Bolt	1	S.11	C	
28M/1011467	A27/ES	Nut, 1/2" BSF	1	—	C	
28W/9419405	SP.15/E	Washer	1	—	C	
191	E.A1.40.341	ROLLER , assembly	1	—	C	
		Attaching parts for E.A1.40.341:—				
189	E.A1.40.345	Bolt	1	S.11	C	
28M/1011467	A27/ES	Nut, 1/2" BSF	1	—	C	
28W/9419405	SP.15/E	Washer	1	—	C	
		Attaching parts for E.A9.40.49:—				
34309	E.A9.40.47	Bolt, special (Mod. 3487)	1	S.96	C	
28M/1011476	A27/JS	Nut, 1/2" BSF	1	—	C	
203	E.A1.40.327	Washer	1	DTD.126A	C	
1889	E.A6.40.23	LINK, STAY, NOSEWHEEL UNDERCARRIAGE AT RADIUS ROD, GROUP	1	—	C	
		Spares for:—				
194	E.A1.40.359	BUSH , bearing	2	DTD.197	C	
195	E.A1.40.361	BUSH , bearing	2	DTD.197	C	
28N/9156370	SP.21	NIPPLE , lubricating	2	—	C	
28N/9156370	SP.21	NIPPLE , lubricating	1	—	C	
1100	EEAS.37/24A	NIPPLE , 1/2" BSF	24	S.11	C	
6187	E.A1.40.415	PAD , undercarriage "down" micro switch ...	1	L.40	C	
3659	E.A3.40.75	PIN , latch	1	S.11	C	
197	E.A1.40.277	PLATE , stop, stay link	1	S.11	C	
3657	E.A3.40.67	SCREW , cap retaining, undercarriage locking plunger	1	L.40	C	
3660	E.A3.40.71	SCREW , grub latch pin and bush retaining ...	1	S.97	C	
199	E.A1.40.431	SPINDLE , hook latch, nosewheel undercarriage stay	1	S.11	C	
	EEAS.38/4A	SPOKE , 1/2" BSF (Make from 28R/6330)	12	S.11	LM	
3658	E.A3.40.69	SPRING , compression, operating locking plunger, 14 SWG	1	Spring Wire	C	

NOSEWHEEL

Ref. No.	Part No.	Description						No. off	Matl. Spec.	Cl. of Equip.		Plate No.
		1	2	3	4	5	6			M.R.	L.M.	
201 5CW/6575	E.A1.40.313 †	SPRING , leaf, for micro switch operating finger						1	Spring Steel		C	
		SWITCH , micro, type 1A, U/C up-lock (Pre-Mod. 4080)						1	—		B	
5CW/11254	†	SWITCH , micro, type 1HY.1, U/C up-lock (Mod. 4080)						1	—		B	
		Attaching parts for Ref. 5CW/6575 or 5CW/11254:—										
28D/1011011	A25/8B	Bolt, 4 BA						2	—		C	
28M/1278189	AGS.2001/B/1	Nut, 4 BA						2	—		C	
28W/9419474	SP.15/B	Washer						2	—		C	
5CW/6672	†	SWITCH , micro, type 4A, U/C down lock (Pre-Mod. 4080)						1	—		B	
5CW/11254	†	SWITCH , micro, type 1HY.1, U/C down lock (Mod. 4080)						1	—		B	
		Attaching parts for Ref. 5CW/6672 or 5CW/11254:—										
28D/1214303	AS.1242/10B	Bolt, 4 BA						2	—		C	
28M/1278189	AGS.2001/B/1	Nut, 4 BA						2	—		C	
28W/9419474	SP.15/B	Washer						2	—		C	
1895	E.B6.40.27	TUBE , strut, nose undercarriage						1	T.60 or T.75		C	
202	E.A1.40.325	WASHER , special						1	DTD.126A		C	
203	E.A1.40.327	WASHER , special, at operating lever bearing ...						1	DTD.126A		C	
3748	E.A1.40.455	SCREW , grub, 2 BA, special, strut bearing retaining						1	S.11		C/MR	
343	E.A1.31.277	SHIM						2	Alumn.		C	
	or											
	EEAS.27/8/4											
204	E.A1.40.599	SPRING , return, undercarriage hook, 14 SWG ...						1	Spring Steel		C	
205	E.A1.40.601	SPRING , tension, undercarriage sequence valve lever, 18 SWG						1	Spring Steel		C	
1587	E.A1.40.719	SPRING						1	Spring Steel		C	
4693	E.A3.40.157	STOP , door jack extension						2	S.11		C/MR	
992	E.A1.40.701	STOP , sequence valve lifter						1	S.11		C	
39192	E.A9.40.37	TAPPET , front latch lever (Mod. 2183)						1	M.S.		C	
	DUNLOP											
27A/2655	KK.2	TUBE , 26" x 6"5 x 14"						2	—		A	
	DUNLOP											
27A/2654	DR.2565 or KKEN.14N	TYRE , 26" x 6"5 x 14"						2	—		A	
	or											
	DUNLOP											
27A/4683	DR.2565	TYRE , 26" x 6"5 x 14"						2	—		A	
	GOODYEAR											
	GA.1202											
	FIRESTONE											
	ZA.297											
	DOWTY											
27Q/1446377	200396.039	UNIT , undercarriage (For spares see A.P.4515B, Vol. 3, Part 1) (Mod. 4451)						1	—		A	

NOSEWHEEL

Ref. No.	Part No.	Description						off	Matl. Spec.	Cl. of Equip.	Plate No.
		1	2	3	4	5	6			M.R. L.M.	
202	E.A1.40.325	WASHER,	special	3	DTD.126A	C	
3752	E.A1.40.587	WASHER,	special packing, undercarriage	sequence				2	DTD.683	C/MR	
1877	EEAS.28/30EU	WASHER,	special, 18 SWG	1	DTD.124	C	
1078	EEAS.28/35FU	WASHER,	special sequence valve fulcrum	1	DTD.124	C	
22329	E.A9.40.17	WASHER,	corner	2	L.72	C	
27A/2814	DUNLOP AH.9590	WHEEL,	landing	2	--	A	

Ref. No.	Part No							Description	off	Matl. Spec.	Cl. of Equip.	Plate No.
		1	2	3	4	5	6				M.R. L.M.	

1843 to 1862

^{1 A2/11}
Pages 1843 to 1862 not issued

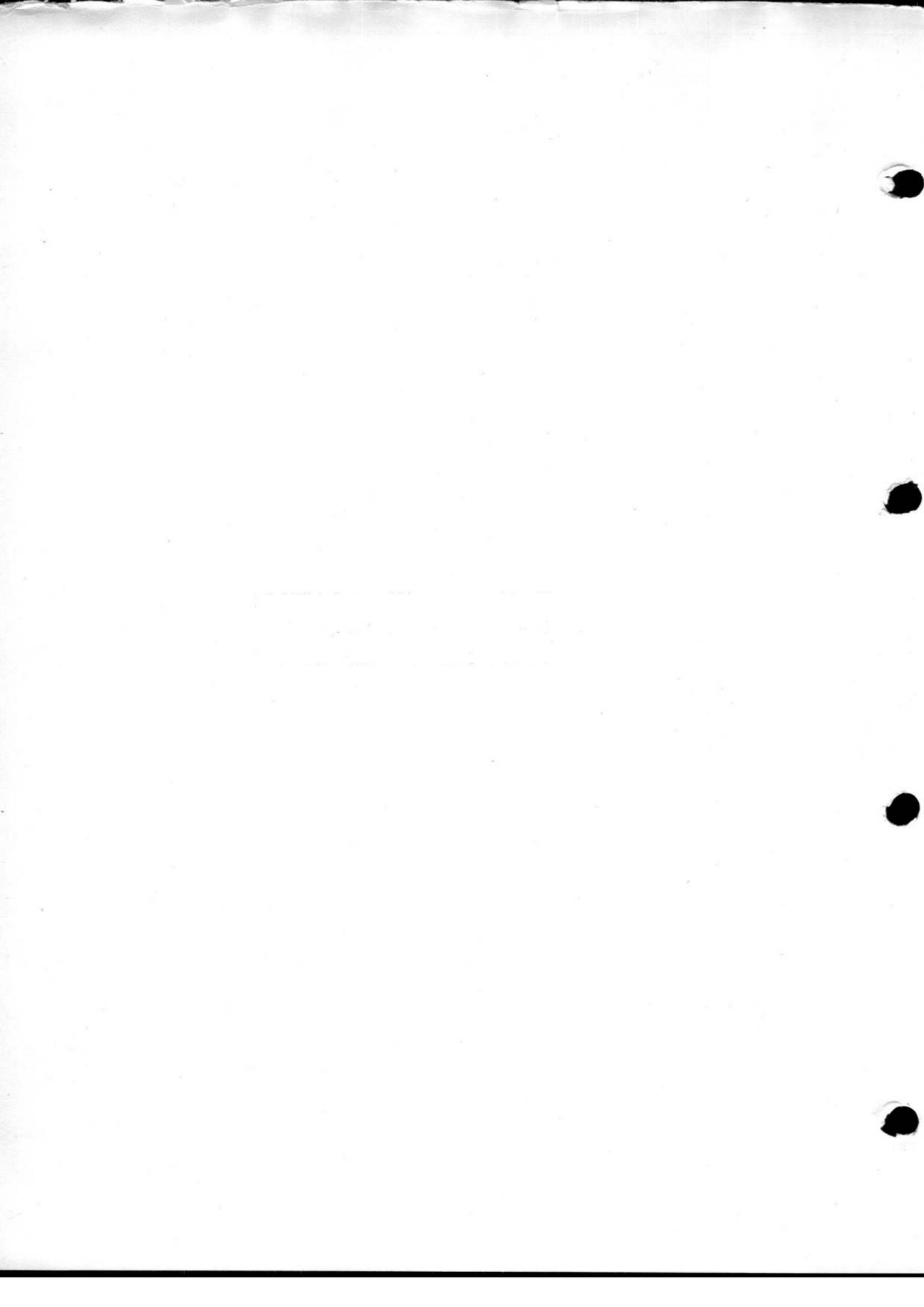

NOSEWHEEL

Ref. No.	Part No.	Description						No. off	Matl. Spec.	Cl. of Equip.	Plate No.
		1	2	3	4	5	6			M.R. L.M.	
SUMMARY OF STOCK ITEMS USED ON NOSE-WHEEL, ASSEMBLY											
28D/1011011	A25/8B	Bolt,	4	BA		C	
28D/1200120	A25/14B	Bolt,	4	BA		C	
28D/9436920	A25/1C	Bolt,	2	BA		C	
28D/9133011	A25/2C	Bolt,	2	BA		C	
28D/9133012	A25/3C	Bolt,	2	BA		C	
28D/9140647	A25/14C	Bolt,	2	BA		C	
28D/1012995	A25/22C	Bolt,	2	BA		C	
28D/9140649	A25/23C	Bolt,	2	BA		C	
28D/1011240	A25/5E	Bolt,	1/4"	BSF		C	
28D/1008145	A25/6E	Bolt,	1/4"	BSF		C	
28D/1011242	A25/7E	Bolt,	1/4"	BSF		C	
28D/1010031	A25/8E	Bolt,	1/4"	BSF		C	
28D/1214303	AS.1242/10B	Bolt,	4	BA		C	
28M/13266	A24/ES	Nut,	1/2"	BSF		C	
28M/1011001	A24/NS	Nut,	1/2"	BSF		C	
28M/9403518	A27/BP	Nut,	4	BA		C	
28M/9403520	A27/CP	Nut,	2	BA		C	
28M/1006473	A27/CT	Nut,	2	BA		C	
28M/1011475	A27/EP	Nut,	1/4"	BSF		C	
28M/1011467	A27/ES	Nut,	1/4"	BSF		C	
28M/1007403	A27/ET	Nut,	1/4"	BSF		C	
28M/1006939	A27/GP	Nut,	5/16"	BSF		C	
28M/5808571	A27/GS	Nut,	3/8"	BSF		C	
28M/1011470	A27/GT	Nut,	3/16"	BSF		C	
28M/1011476	A27/JS	Nut,	3/8"	BSF		C	
28M/9129449	A27/LS	Nut,	7/16"	BSF		C	
28M/10287	AGS.2001/B/1	Nut,	stiff,	4 BA		C	
28M/10288	AGS.2001/C/1	Nut,	stiff,	2 BA		C	
28M/10290	AGS.2001/E/1	Nut,	stiff,	1/4" BSF		C	
28M/10292	AGS.2001/J/1	Nut,	stiff,	3/8" BSF		C	
28M/10339	AGS.2002/C/2	Nut,	stiff,	2 BA		C	
28P/9527619	SP.90/C7	Pin,	split		C	
28P/19234	SP.90/E8	Pin,	split		C	
28P/19157	SP.90/G10	Pin,	split		C	
28S/9419194	A31/C12	Screw,	2	BA		C	
28S/9997545	A31/C16	Screw,	2	BA		C	
28S/9146378	A35/C8	Screw,	2	BA		C	
28W/9419402	SP.13/C	Washer		C	
28W/9418921	SP.13/E	Washer		C	
28W/9419403	SP.13/G	Washer		C	
28W/9419467	SP.13/L	Washer		C	
28W/9419474	SP.15/B	Washer		C	
28W/9419475	SP.15/C	Washer		C	
28W/9419405	SP.15/E	Washer		C	
28W/9419478	SP.15/L	Washer		C	
28W/9419489	SP.16/J	Washer		C	
28W/9416642	SP.47/B	Washer		C	
28W/9416632	SP.47/C	Washer		C	
28W/9416644	SP.47/E	Washer		C	
28W/1009699	SP.55/C	Washer		C	

Restricted

Ref. No.	Part No.	1	2	3	4	5	6	Description	off	Matl. Spec.	Cl. of Equip.	Plate No.
											M.R.	

Plate U.1

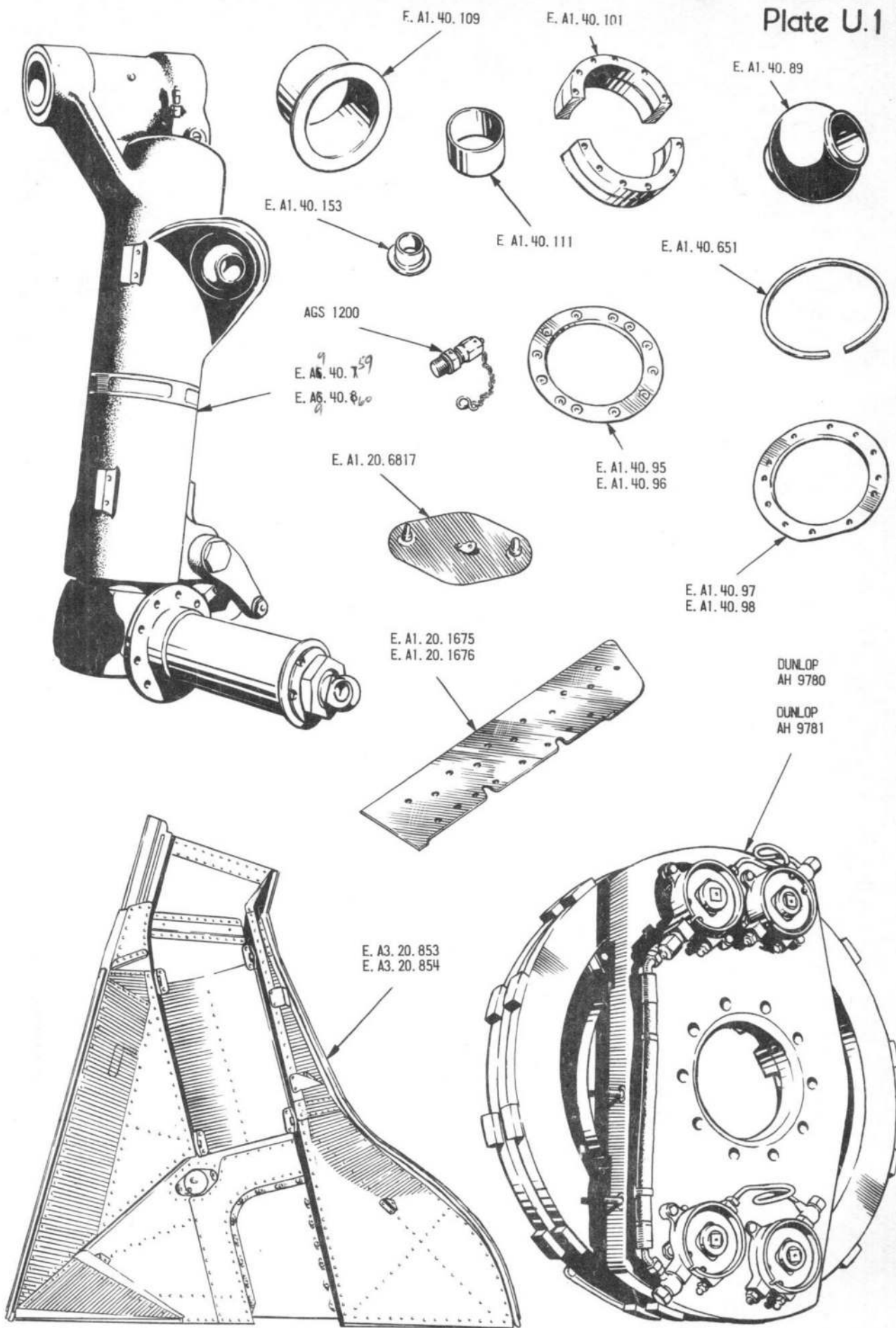

MAIN U/C OLEO LEG, FAIRING AND BRAKE UNIT

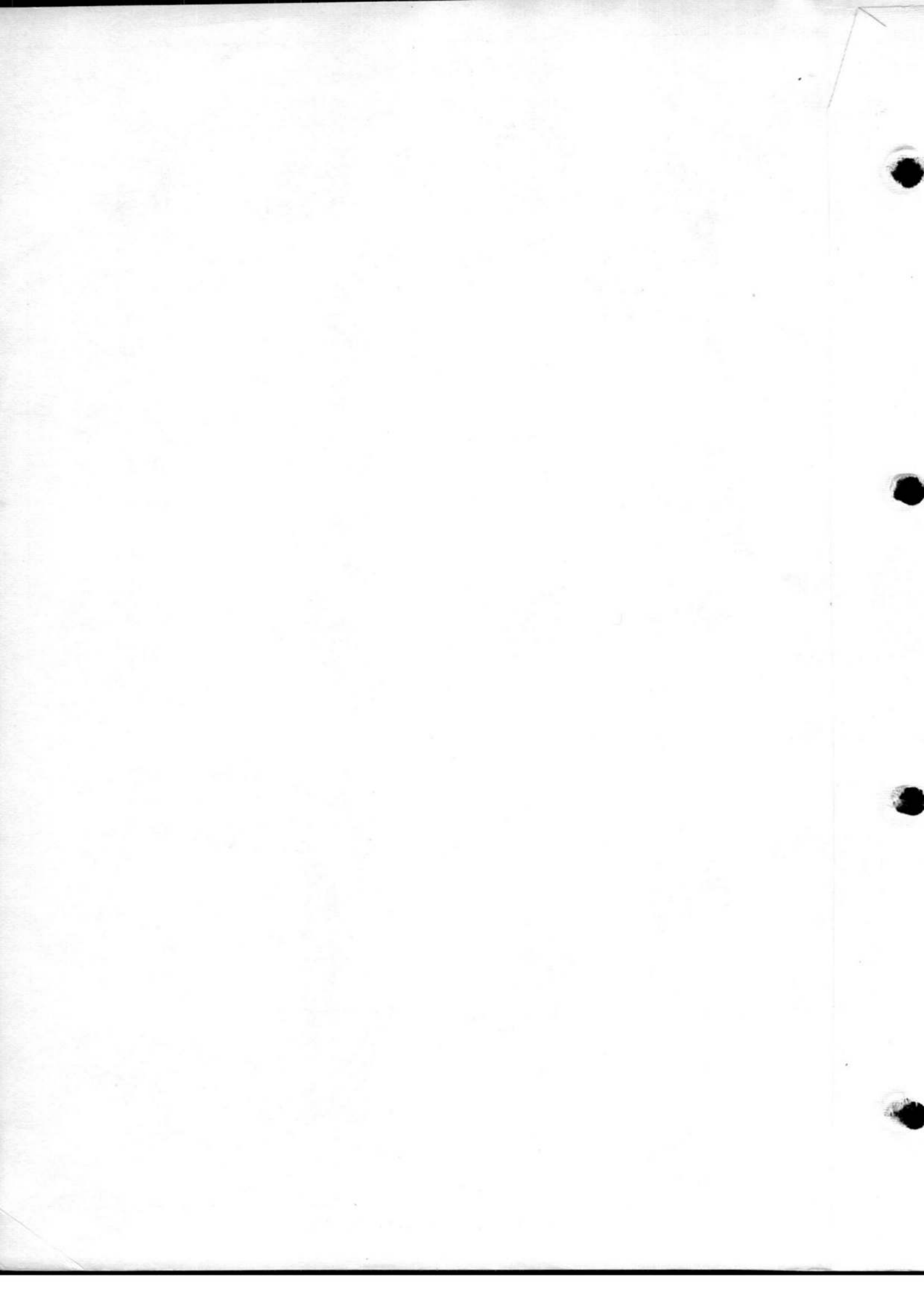

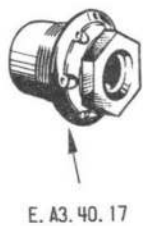
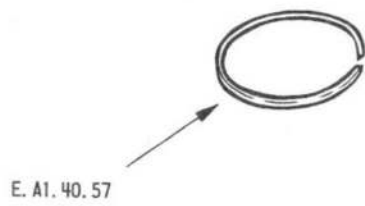
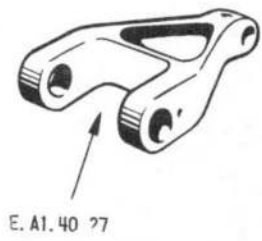
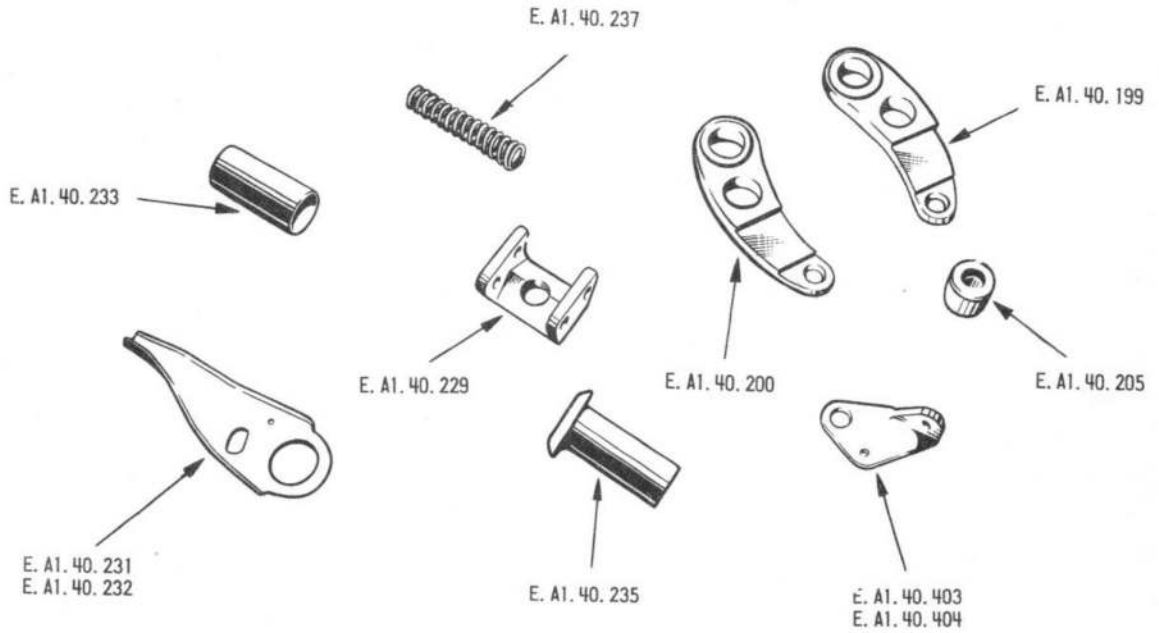
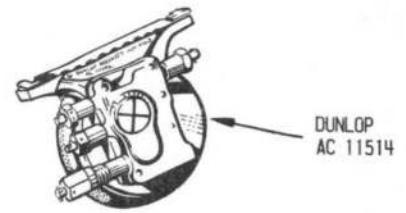
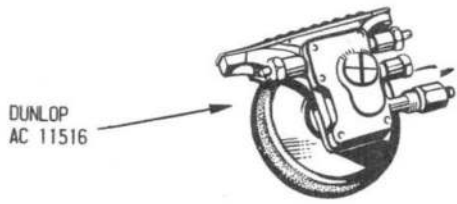

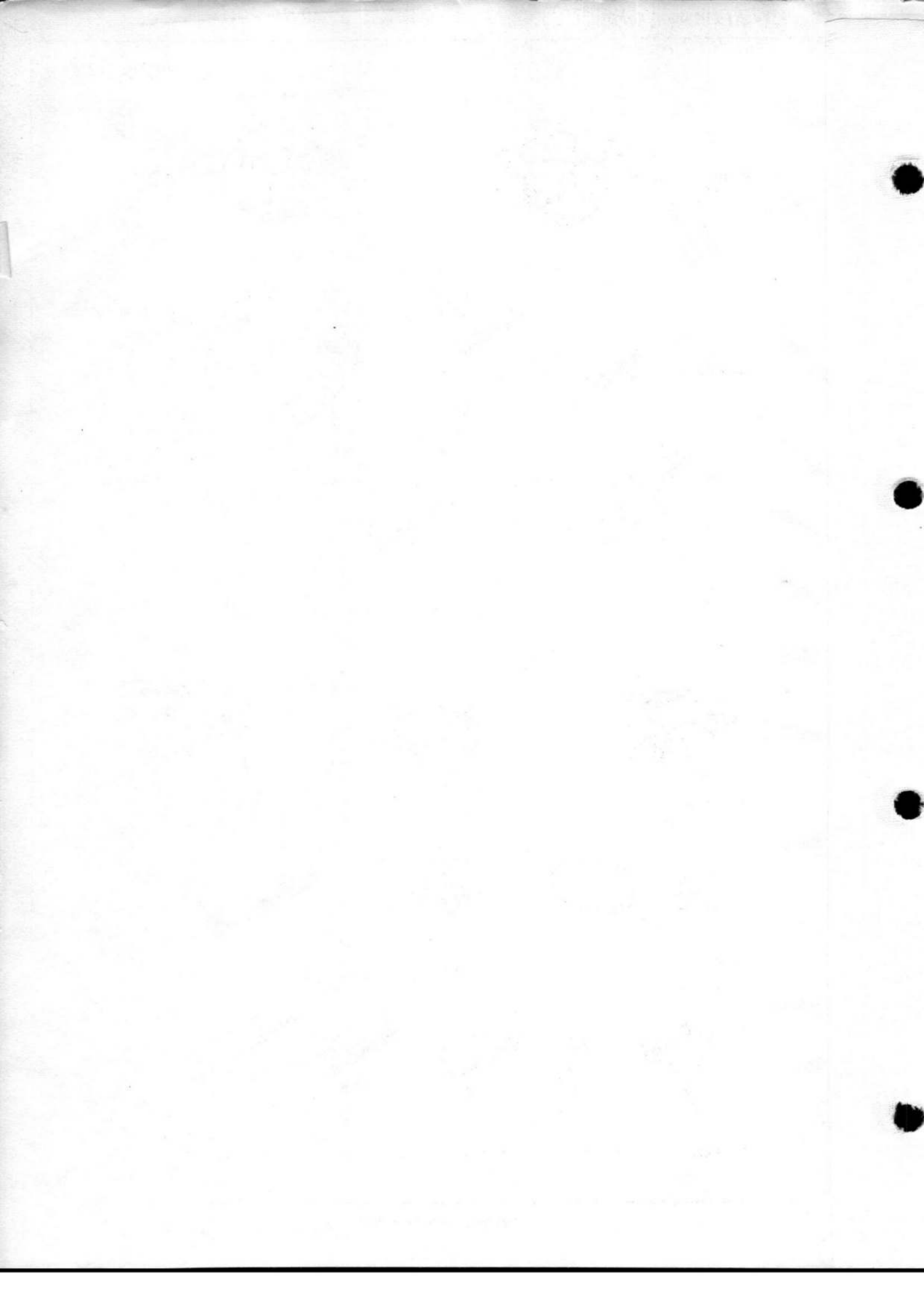

This file was downloaded
from the RTFM Library.

Link: www.scottbouch.com/rtfm

Please see site for usage terms,
and more aircraft documents.

