

**EQUIPMENT, ANCILLARY  
GROUND EQUIPMENT**

| Ref. No.     | Part No.        | Description  | No. off  | Matl. Spec.  | Cl. of Equip. | Plate No. |
|--------------|-----------------|--|----------|--------------|---------------|-----------|
|              |                 |  |          |              | M.R. L.M.     |           |
|              |                 | 1 2 3 4 5 6  |          |              |               |           |
|              | E.A9.88.1       | <b>GROUND, EQUIPMENT, ASSEMBLY</b> ... ..  | —        | —            | —             |           |
|              |                 | Spares for:—   |          |              |               |           |
| 4Q/2627      | E.A1.88.77      | <b>ADAPTOR</b> , fuselage jacking ... ..   | 1        | —            | B             | GE.1      |
| 95087        | E.A3.88.157     | <b>ARM, NOSEWHEEL STEERING, ASSEMBLY</b> ... ..  | 1        | —            | A             | GE.1      |
|              |                 | Spares for:—   |          |              |               |           |
| 20870        | E.A3.88.57      | <b>ARM, STEERING, ATTACHMENT</b> ... ..  | 1        | —            | A/MR          |           |
|              |                 | Spares for:—   |          |              |               |           |
| 21123        | E.A3.88.47      | <b>BAR</b> , release, axle pin ... ..  | 2        | —            | C/MR          |           |
| 21124        | E.A3.88.49      | <b>BAR</b> , release, plunger ... ..   | 2        | —            | C/MR          |           |
| 21218        | E.A3.88.51      | <b>BUSH</b> ... ..   | 2        | —            | C/MR          |           |
| 40109        | E.A3.88.41      | <b>GUIDE</b> , axle pin ... ..   | 2        | —            | C/MR          |           |
| 95459        | E.A3.88.43      | <b>GUIDE</b> , plunger ... ..  | 2        | —            | C/MR          |           |
| 26190        | E.A3.88.55      | <b>PIN</b> , adaptor ... ..  | 2        | —            | C/MR          |           |
| 22988        | E.A3.88.25      | <b>PIN</b> , axle, port ... ..   | 1        | —            | C/MR          |           |
| 21120        | E.A3.88.27      | <b>PIN</b> , axle, starboard ... ..  | 1        | —            | C/MR          |           |
| 21122        | E.A3.88.45      | <b>PLUNGER</b> ... ..  | 2        | —            | C/MR          |           |
| 21219        | E.A3.88.69      | <b>SPRING</b> ... ..   | 2        | —            | C/MR          |           |
| 95460        | E.A3.88.53      | <b>WASHER</b> , saddle ... ..  | 2        | —            | C/MR          |           |
| 95494        | FLEXELLO 633-C1 | <b>CASTOR</b> , unit ... ..  | 2        | —            | B             |           |
| 95022        | E.A3.88.15      | <b>ATTACHMENT, NOSE TOWING BAR, ASSEMBLY</b> ... ..  | 1        | —            | A             | GE.1      |
|              |                 | Spares for this assembly are identical with those for Pt. No. E.A3.88.57, except for the following deletion and addition |          |              |               |           |
|              |                 | Delete:—   |          |              |               |           |
| 26190        | E.A3.88.55      | <b>PIN</b> , adaptor ... ..  | 2        | —            | C/MR          |           |
|              |                 | Add:—  |          |              |               |           |
| 25733        | E.A3.88.37      | <b>PIN</b> , adaptor ... ..  | 2        | —            | C/MR          |           |
| 95539        | LFDS/4319       | <b>ASSISTOR</b> , Duro triple bomb carrier (Mod. 2671)   | 1        | —            | B             |           |
| 4G/2792      | †               | <b>BAR</b> , towing ... ..   | 1        | —            | A             |           |
| 27Q/32596    | MT.1093         | <b>BLOCK</b> , split for air brakes ... ..   | 1        | —            | B             | GE.1      |
| 95299        | E.A3.88.297     | <b>BLOCK</b> , removal, No. 1 and 2 fuel tank vents ...  | Set of 2 | —            | B             |           |
| 95413        | E.A3.88.307     | <b>BRACKET, MAIN WHEEL JACKING, ASSEMBLY</b> ...   | 2        | —            | B             |           |
|              |                 | Spares for:—   |          |              |               |           |
| 21870        | E.A3.88.219     | <b>BOLT</b> , special ... ..   | 2        | S.94 or S.95 | C             |           |
| 95013        | E.A3.88.79      | <b>BRIDGE</b> , detachable, for wing slinging ... ..   | 1        | —            | B             | GE.1      |
| 95012        | E.A1.88.89      | <b>CABLES</b> , retaining, bomb doors ... ..   | 2        | —            | B             |           |
| 95489        | E.A9.88.211     | <b>CABLE</b> , control column retainer ... ..  | 1        | BS.6W2/6     | C             |           |
| 1867         | E.A1.88.73      | <b>CLAMP, ELEVATOR LOCKING, STARBOARD, ASSEMBLY</b> ... ..   | 1        | —            | B             | GE.1      |
| 13142        | E.A1.88.873     | <b>CLAMP, ELEVATOR LOCKING, PORT, ASSEMBLY</b> ... ..  | 1        | —            | B             |           |
|              |                 | Spares for:—   |          |              |               |           |
| 20736        | E.A1.88.185     | <b>PENNANT</b> ... ..  | 1        | —            | C             |           |
| 28FP/29      | A.617           | <b>PIN</b> , "pip" ... ..  | 2        | —            | C             |           |
| 1971         | E.A3.88.91      | <b>CLAMP, AILERON LOCKING, ASSEMBLY</b> ... ..   | 1        | —            | B             |           |
|              |                 | Spares for:—   |          |              |               |           |
| 6799         | E.A3.88.103     | <b>PENNANT</b> ... ..  | 2        | —            | C             |           |
| 6800         | E.A3.88.101     | <b>STRAP</b> , assembly ... ..   | 1        | —            | C             |           |
| 1972         | E.A3.88.92      | <b>CLAMP, AILERON LOCKING, ASSEMBLY</b> ... ..   | 1        | —            | B             |           |
|              |                 | Spares for:—   |          |              |               |           |
| 6799         | E.A3.88.103     | <b>PENNANT</b> ... ..  | 2        | —            | C             |           |
| 20738        | E.A3.88.102     | <b>STRAP</b> , assembly ... ..   | 1        | —            | C             |           |
| 2468         | E.A3.88.153     | <b>CLAMP, RUDDER LOCKING, ASSEMBLY</b> ... ..  | 2        | —            | B             | GE.1      |
|              |                 | Spares for:—   |          |              |               |           |
| 28FP/9432062 | A.413           | <b>PIN</b> , "pip" ... ..  | 1        | —            | C             |           |
| 14747        | TERRY EX. 12    | <b>SPRING</b> ... ..   | 1        | —            | C             |           |
| 95298        | E.A3.88.205     | <b>COVER</b> , blanking, No. 1 and 2 fuel tank vents ...   | Set of 2 | —            | B             | GE.1      |
| 27D/2991     | E.A9.88.27      | <b>COVER</b> , engine ... ..   | 2        | —            | B             |           |
| 27D/2993     | E.A9.88.29      | <b>COVER</b> , coupe ... ..  | 1        | —            | B             |           |

**EQUIPMENT, ANCILLARY  
GROUND EQUIPMENT**

| Ref. No. | Part No.                                       | Description  | No. off | Matl. Spec. | Cl. of Equip. |      | Plate No. |
|----------|--|--|---------|-------------|---------------|------|-----------|
|          |  |  |         |             | M.R.          | L.M. |           |
|          |  | 1 2 3 4 5 6  |         |             |               |      |           |
| 27D/2992 | E.A.9.88.31<br>E.A.1.88.399                    | <b>COVER</b> , nose ... ..<br><b>COVERS, AIRCRAFT, ASSEMBLY</b> ... ..<br>Spares for:— | 1<br>—  | —<br>—      | B<br>—        |      |           |
| 27D/2811 | E.A.1.88.405                                   | <b>COVER</b> , jet pipe ... ..   | 2       | —           | B             |      |           |
| 27D/2807 | E.A.1.88.407                                   | <b>COVER</b> , main wheel ... ..   | 2       | —           | B             |      |           |
| 27D/2806 | E.A.1.88.409                                   | <b>COVER</b> , nosewheel ... ..  | 2       | —           | B             |      |           |
| 95442    | E.B.6.88.85                                    | <b>COWLING</b> , slave, port and starboard ... ..                                      | 2       | —           | A             |      |           |
| 95109    | E.A.3.88.211                                   | <b>CRADLE</b> , for handling jettisonable wing tanks ... ..                            | 1       | —           | A             |      |           |
| 95037    | E.A.1.88.417                                   | <b>CRADLE</b> , retraction test (For use at frame 13) ... ..                           | 1       | —           | A             |      |           |
| 95038    | E.A.1.88.419                                   | <b>CRADLE</b> , retraction test (For use at frame 29) ... ..                           | 1       | —           | A             |      |           |
| 95113    | ALVIS AS.18086                                 | <b>CRADLE</b> , bomb trolley ... ..  | 1       | —           | A             |      |           |
| 95072    | E.A.1.88.551                                   | <b>DISC</b> , setting, engine controls, starboard, 12 SWG                              | 1       | L.72        | B             |      | GE.2      |
| 95408    | E.B.6.88.27                                    | <b>DISC</b> , setting, engine controls, port, 12 SWG ... ..                            | 1       | L.72        | B             |      |           |
|          | —  | <b>EQUIPMENT, SIGHTING COMPASS ALIGNMENT,<br/>GROUP (MOD. 2627)</b><br>Spares for:—    | —       | —           | —             |      |           |
| 95563    | E.A.9.88.481                                   | <b>CASE</b> , carrying, assembly ... ..  | 1       | —           | B             |      |           |
| 95562    | E.A.9.88.479                                   | <b>ROD, SIGHTING, ASSEMBLY, AFT</b> ... ..<br>Spares for:—                             | 1       | —           | A             |      |           |
|          | E.A.9.88.497                                   | <b>BRACKET</b> , mounting (spirit level) ... ..  | 1       | —           | —             |      |           |
|          | E.A.9.88.445                                   | <b>BRACKET</b> , rod sighting ... ..   | 1       | —           | —             |      |           |
|          | E.A.9.88.447                                   | <b>JOINT</b> , ball (inner) ... ..   | 1       | DEF.13A     | —             |      |           |
|          | E.A.9.88.449                                   | <b>JOINT</b> , ball (outer) ... ..   | 1       | DEF.13A     | —             |      |           |
|          | E.A.9.88.467                                   | <b>KNOB</b> ... ..   | 1       | DEF.13A     | —             |      |           |
|          | COOKE,<br>TROUGHTON<br>AND SIME, LTD.<br>E.985 | <b>LEVEL</b> , spirit, circular ... ..   | 1       | —           | —             |      |           |
|          | E.A.9.88.495                                   | <b>SHAFT</b> ... ..  | 1       | —           | —             |      |           |
|          | E.A.9.88.469                                   | <b>STUD</b> , special ... ..   | 1       | DEF.13A     | —             |      |           |
| 95561    | —  | <b>ROD, SIGHTING, ASSEMBLY, FORWARD</b> ... ..<br>Spares for:—                         | 1       | —           | A             |      |           |
|          | E.A.9.88.513                                   | <b>BRACKET</b> , mounting (spirit level) ... ..  | 1       | DEF.13A     | —             |      |           |
|          | E.A.9.88.505                                   | <b>CHUCK</b> , inner portion ... ..  | 1       | DEF.13A     | —             |      |           |
|          | E.A.9.88.507                                   | <b>CHUCK</b> , sleeve ... ..   | 1       | DEF.13A     | —             |      |           |
|          | E.A.9.88.515                                   | <b>CLIP</b> ... ..   | 2       | DEF.13A     | —             |      |           |
|          | E.A.9.88.447                                   | <b>JOINT</b> , ball (inner) ... ..   | 1       | DEF.13A     | —             |      |           |
|          | E.A.9.88.449                                   | <b>JOINT</b> , ball (outer) ... ..   | 1       | DEF.13A     | —             |      |           |
|          | E.A.9.88.517                                   | <b>JOINT</b> , ball (rod end) ... ..   | 1       | DEF.13A     | —             |      |           |
|          | COOKE,<br>THROUGHTON<br>AND SIME LTD.<br>E.985 | <b>LEVEL</b> , spirit, circular ... ..   | 1       | —           | —             |      |           |
|          | E.A.9.88.509                                   | <b>PLATE</b> , sighting ... ..   | 1       | DEF.13A     | —             |      |           |
|          | E.A.9.88.519                                   | <b>ROD</b> ... ..  | 1       | DEF.13A     | —             |      |           |
|          | E.A.9.88.511                                   | <b>TIP</b> , sighting ... ..   | 1       | DEF.13A     | —             |      |           |
|          | E.A.9.88.503                                   | <b>TUBE</b> , (1½" o/d. x 22 SWG) ... ..   | 1       | —           | —             |      |           |
| 95292    | A.6300   | <b>EXTRACTOR</b> , and assembly tool, for wheels                                       | 1       | —           | B             |      |           |
| 95462    | E.B.6.88.103                                   | <b>EXTRACTOR</b> , rudder blow back rod (Mod. 1912) ... ..                             | 1       | —           | A             |      |           |
| 95047    | E.A.1.88.359                                   | <b>EXTRACTOR</b> , wing to fuselage pick up pins ... ..                                | 1       | —           | A             |      | GE.2      |
| 95044    | E.A.1.88.375                                   | <b>EXTRACTOR</b> , for tab torque tube lever ... ..                                    | 1       | —           | A             |      | GE.2      |
| 95104    | E.A.1.88.825                                   | <b>EXTRACTOR</b> , for aileron hinge pin ... ..  | 1       | —           | A             |      | GE.2      |
| 27G/5105 | A.10056  | <b>FIXTURE</b> , hydraulic brake alignment ... ..                                      | 1       | —           | A             |      |           |
|          | E.A.1.88.91                                    | <b>FORMERS, ASSEMBLY, DRAWING, PORT</b> ... ..   | —       | —           | —             |      |           |
| 95025    | E.A.1.88.91A                                   | <b>FORMER</b> , wing lifting gantry, forward, port ... ..                              | 1       | —           | B             |      | GE.2      |
| 95026    | E.A.1.88.91B                                   | <b>FORMER</b> , wing lifting gantry, centre, port ... ..                               | 1       | —           | B             |      | GE.2      |
| 95027    | E.A.1.88.91C                                   | <b>FORMER</b> , wing lifting gantry, aft, port ... ..                                  | 1       | —           | B             |      | GE.2      |
| 95028    | E.A.1.88.91D                                   | <b>FORMER</b> , wing lifting gantry, forward, port ... ..                              | 1       | —           | B             |      | GE.2      |
| 95029    | E.A.1.88.91E                                   | <b>FORMER</b> , wing lifting gantry, centre, port ... ..                               | 1       | —           | B             |      | GE.2      |
| 95030    | E.A.1.88.91F                                   | <b>FORMER</b> , wing lifting gantry, aft, port ... ..                                  | 1       | —           | B             |      | GE.2      |

**EQUIPMENT, ANCILLARY  
GROUND EQUIPMENT**

| Ref. No.            | Part No.       | Description   |   |   |   |   |   | No. off | Matl. Spec. | Cl. of Equip. | Plate No. |
|---------------------|----------------|---|---|---|---|---|---|---------|-------------|---------------|-----------|
|                     |                | 1   | 2 | 3 | 4 | 5 | 6 |         |             | M.R.<br>L.M.  |           |
|                     | E.A1.88.92     | <b>FORMERS, ASSEMBLY, DRAWING, STARBOARD</b>  |   |   |   |   |   | —       | —           | —             |           |
| 95031               | E.A1.88.92A    | <b>FORMER</b> , wing lifting gantry, forward starboard  |   |   |   |   |   | 1       | —           | B             | GE.2      |
| 95032               | E.A1.88.92B    | <b>FORMER</b> , wing lifting gantry, centre, starboard ...  |   |   |   |   |   | 1       | —           | B             | GE.2      |
| 95033               | E.A1.88.92C    | <b>FORMER</b> , wing lifting gantry, aft, starboard ...   |   |   |   |   |   | 1       | —           | B             | GE.2      |
| 95034               | E.A1.88.92D    | <b>FORMER</b> , wing lifting gantry, forward, starboard   |   |   |   |   |   | 1       | —           | B             | GE.2      |
| 95035               | E.A1.88.92E    | <b>FORMER</b> , wing lifting gantry, centre, starboard ...  |   |   |   |   |   | 1       | —           | B             | GE.2      |
| 95036               | E.A1.88.92F    | <b>FORMER</b> , wing lifting gantry, aft, starboard ...   |   |   |   |   |   | 1       | —           | B             | GE.2      |
| 95115               | E.A3.88.179    | <b>GAUGE</b> , tailplane incidence and dihedral ...   |   |   |   |   |   | 1       | —           | B             |           |
| 95010               | E.A1.88.93     | <b>GAUGE</b> , wing incidence and dihedral ...  |   |   |   |   |   | 1       | —           | B             |           |
| 95470               | E.A9.88.63     | <b>GAUGE</b> , levelling, cockpit lateral and fuselage longitudinal                                 |   |   |   |   |   | 1       | —           | A             |           |
| 95469               | E.A9.88.57     | <b>GAUGE</b> , levelling, cockpit longitudinal and fuselage lateral                                 |   |   |   |   |   | 1       | —           | A             |           |
| 95468               | E.A9.88.47     | <b>GAUGE</b> , levelling, centre fuselage lateral ...   |   |   |   |   |   | 1       | —           | A             |           |
| 95528               | E.A9.88.213    | <b>GAUGE</b> , setting, static vent (Mod. 2102) ...   |   |   |   |   |   | 1       | —           | A             |           |
| 95100               | E.A1.88.823    | <b>GAUGE</b> , aileron, fixed tab, angle checking ...   |   |   |   |   |   | 1       | —           | B             |           |
| 95653               | —              | <b>GAUGES</b> , clearance, aileron shroud screen ...<br>(Supplied in set of three)                  |   |   |   |   |   | 1       | —           | B             |           |
| 95273               | E.A1.88.785    | <b>GEAR, LIFTING, COMPLETE AIRCRAFT, ASSEMBLY</b>   |   |   |   |   |   | 2       | —           | A             |           |
|                     |                | Spares for:—  |   |   |   |   |   |         |             |               |           |
| 95526               | E.A3.88.317    | <b>BOLT</b> , special, shouldered ...   |   |   |   |   |   | 2       | S.97        | C             |           |
| 95527               | E.A3.88.319    | <b>WASHER</b> , special ...   |   |   |   |   |   | 2       | M.S.        | C             |           |
| 95276               | E.B7.88.15     | <b>GUARD, AIR INTAKE, DEBRIS, ASSEMBLY (FOR USE ON A/C, NOT EMBODYING AVON MOD. 843)</b>            |   |   |   |   |   | 2       | —           | A             |           |
|                     |                | Spares for:—  |   |   |   |   |   |         |             |               |           |
| 95503               | E.A3.88.295    | <b>BOLT</b> , key ...   |   |   |   |   |   | 2       | M.S.        | C             |           |
| 95538               | E.B7.88.205    | <b>GUARD, AIR INTAKE, DEBRIS, ASSEMBLY (FOR USE ON A/C, EMBODYING AVON MOD. 843) (MOD. GE.2396)</b> |   |   |   |   |   | 2       | —           | A             |           |
|                     |                | Spares for:—  |   |   |   |   |   |         |             |               |           |
| 33C/<br>28S/1214853 | †<br>4100/8/8" | <b>ADHESIVE</b> , P.R.C. compound ...   |   |   |   |   |   | QR      | —           | —             |           |
|                     | E.B7.88.207    | <b>SCREW</b> , P.K. ...   |   |   |   |   |   | 21      | —           | C             |           |
|                     | E.B7.88.209    | <b>SEGMENT</b> ...  |   |   |   |   |   | 3       | LFS.21      | —             |           |
|                     |                | <b>STRIP</b> , felt, 3/8" x 1" x 38" long ...   |   |   |   |   |   | 1       | DTD.590     | —             |           |
| 1B/4467             | †              | <b>GUN</b> , lubricating ...  |   |   |   |   |   | 1       | —           | A             |           |
| 95080               | AT.81489       | <b>HANDLE</b> , crutching ...   |   |   |   |   |   | 1       | —           | A             |           |
| 95449               | E.A9.88.39     | <b>HEAD</b> , jacking, for 15-ton, pillar jack ...  |   |   |   |   |   | 2       | M.S.        | A             |           |
| 4Q/2626             | E.A1.88.257    | <b>HEAD</b> , 10-ton jack adaptor ...   |   |   |   |   |   | 1       | DTD.124     | A             |           |
| 95293               | E.A1.88.831    | <b>INDICATOR</b> , engine controls, setting disc, 20 SWG  |   |   |   |   |   | 1       | —           | B             |           |
| 95051               | E.A1.88.349    | <b>INDICATOR</b> , piston ring, main undercarriage oleo leg   |   |   |   |   |   | 1       | —           | B             |           |
| 95048               | E.A1.88.363    | <b>INSERTER</b> , wing to fuselage pick-up pins ...   |   |   |   |   |   | 1       | —           | B             |           |
| 95052               | E.A1.88.383    | <b>INSERTER</b> , main oleo, pivot point bush ...   |   |   |   |   |   | 1       | —           | B             |           |
| 95050               | E.A1.88.389    | <b>INSERTER</b> , for bushes in torque links main oleo leg  |   |   |   |   |   | 1       | —           | B             |           |
| 95053               | E.A1.88.391    | <b>INSERTER</b> , and extractor, for sealing rings, main oleo leg                                   |   |   |   |   |   | 1       | —           | B             |           |
| 95088               | E.A1.88.733    | <b>INSERTER</b> , main undercarriage pivot pin ...  |   |   |   |   |   | 1       | —           | A             |           |
| 4Q/2232             | †              | <b>JACK</b> , hydraulic, fuselage ...   |   |   |   |   |   | 1       | —           | A             |           |
| 4Q/2625             | †              | <b>JACK</b> , hydraulic, main wing ...  |   |   |   |   |   | 1       | —           | B             |           |
| 95614               | E.A9.88.5007   | <b>JIG</b> , drill, canopy yoke (Mod. 4021) ...   |   |   |   |   |   | 1       | —           | B             |           |
| 95063               | E.A1.88.395    | <b>KEY</b> , hydraulic, tank ...  |   |   |   |   |   | 1       | —           | B             |           |
| 1970                | E.A1.40.169    | <b>LUG</b> , picketing and towing ...   |   |   |   |   |   | 6       | S.11        | C             |           |

**EQUIPMENT, ANCILLARY  
GROUND EQUIPMENT**

| Ref. No.    | Part No.         | Description   | No. off | Matl. Spec. | Cl. of Equip. |   | Plate No. |
|-------------|------------------|---|---------|-------------|---------------|---|-----------|
|             |                  |   |         |             | M.R. L.M.     |   |           |
|             |                  |   |         |             |               |   |           |
|             |                  | 1 2 3 4 5 6   |         |             |               |   |           |
| 27Q/11743   | DOWTY<br>D.2606Y | <b>NOZZLE</b> , flexible, c/w gauge ... ..                                    | 1       | —           |               | A |           |
| 95523       | E.A9.88.37       | <b>PIN</b> , locking, canopy jettison ram, c/w pennant ...                    | 1       | —           |               | C |           |
| 95471       | E.A9.88.71       | <b>PIN</b> , safety, wind break door, c/w pennant ...                         | 1       | —           |               | C |           |
| 95015       | E.A1.88.255      | <b>PIN</b> , nosewheel locking ... ..   | 1       | —           |               | B |           |
| 95407       | E.B6.88.29       | <b>PLATE</b> , setting, bell crank lever, engine control, port                | 1       | —           |               | B |           |
| 95295       | E.A1.88.548      | <b>PLATE</b> , setting, bell crank lever, engine control, starboard           | 1       | —           |               | A |           |
| 95074       | E.A1.88.549      | <b>PLATE</b> , setting, throttle box, 16 SWG ... ..                           | 1       | —           |               | A |           |
| 95270       | E.A3.88.281      | <b>PLUG, BLANKING, CABIN PRESSURE CONTROL VALVE, GROUP</b><br>Consisting of:— | 1       | L.72        |               | A |           |
|             | —                | <b>CHAIN</b> , retaining ... ..   | QR      | Brass       |               | — |           |
| 21084       | E.A2.88.77       | <b>PENNANT</b> ... ..   | 1       | —           |               | C |           |
|             | E.A3.88.283      | <b>PLUG</b> ... ..  | 1       | L.40        |               | — |           |
|             | —                | <b>RING</b> , split, $\frac{3}{4}$ " o/d x $\frac{1}{16}$ " ... ..            | 2       | —           |               | — |           |
| 6A/2679     | †<br>E.A9.88.559 | <b>PLUGS</b> , protective, static vents ... ..                                | 4       | —           |               | A |           |
|             | E.B6.88.173      | <b>RIGGING FOR GYRO INSTALLATION (MOD. 2508)</b><br>Spares for:—              | —       | —           |               | — |           |
|             | E.B6.88.185      | <b>CRADLE, ASSEMBLY</b> ... ..  | 1       | —           |               | — |           |
|             | E.B6.88.175      | <b>ADJUSTER</b> ... ..  | 4       | S.1         |               | — |           |
|             | E.B6.88.187      | <b>CRADLE</b> ... ..  | 1       | —           |               | — |           |
|             | E.B6.88.179      | <b>FOOT</b> ... ..  | 4       | —           |               | — |           |
|             | E.B6.88.177      | <b>INDICATOR</b> ... ..   | 2       | —           |               | — |           |
|             | E.B6.88.189      | <b>INDICATOR, support</b> ... ..  | 2       | —           |               | — |           |
|             | E.B6.88.273      | <b>PAD</b> , rubber ... ..  | 4       | —           |               | — |           |
|             | E.B6.88.281      | <b>SCREW</b> , clamping ... ..  | 2       | —           |               | — |           |
|             | E.B6.88.229      | <b>FRAMES, GYRO ALIGNMENT, GROUP (MOD. 2639)</b><br>Spares for:—              | 1       | —           |               | — |           |
|             | E.B6.88.283      | <b>CASE</b> , carrying ... ..   | 1       | —           |               | — |           |
|             | E.B6.88.287      | <b>FRAME "A", ALIGNMENT, GROUP</b> ... ..<br>Spares for:—                     | 1       | —           |               | — |           |
|             | E.B6.88.209      | <b>BEAM, ASSEMBLY</b> ... ..  | 2       | —           |               | — |           |
|             | E.B6.88.219      | <b>BEAM</b> , assembly ... ..   | 1       | —           |               | — |           |
|             | E.B6.88.221      | <b>Consisting of:—</b><br><b>FORK-END, L.H.</b> ... ..                        | 1       | S.92        |               | — |           |
|             | E.B6.88.225      | <b>FORK-END, R.H.</b> ... ..  | 1       | S.92        |               | — |           |
| 28M/1007404 | A27/JT           | <b>NUT</b> , $\frac{3}{8}$ " BSF ... ..                                       | 1       | —           |               | C |           |
| 28M/13811   | A27/JTL          | <b>NUT</b> , $\frac{3}{8}$ " BSF ... ..                                       | 1       | —           |               | C |           |
|             | E.B6.88.295      | <b>BEAM, ASSEMBLY</b> ... ..  | 1       | —           |               | — |           |
|             | E.B6.88.213      | <b>Consisting of:—</b><br><b>BEAM</b> , assembly ... ..                       | 1       | —           |               | — |           |
|             | E.B6.88.223      | <b>EYE-END, L.H.</b> ... ..   | 1       | S.92        |               | — |           |
|             | E.B6.88.225      | <b>EYE-END, R.H.</b> ... ..   | 1       | S.92        |               | — |           |
| 28M/1007404 | A27/JT           | <b>NUT</b> , $\frac{3}{8}$ " BSF ... ..                                       | 1       | —           |               | C |           |
| 28M/13811   | A27/JTL          | <b>NUT</b> , $\frac{3}{8}$ " BSF ... ..                                       | 1       | —           |               | C |           |
|             | E.B6.88.297      | <b>PIN</b> , locating ... ..  | 2       | —           |               | — |           |
|             | 28M/1011467      | <b>Attaching parts for E.B6.88.297:—</b><br>Nut, $\frac{1}{4}$ " BSF ... ..   | 1       | —           |               | C |           |
|             | 28P/9995880      | Pin, split ... ..   | 1       | —           |               | C |           |
|             | 28W/14395        | Washer, saddle ... ..   | 2       | —           |               | C |           |

**EQUIPMENT, ANCILLARY  
GROUND EQUIPMENT**

| Ref. No.    | Part No.       | Description  |   |   |   |   |   | No. off | Matl. Spec.  | Cl. of Equip.<br>M.R.<br>L.M. | Plate No. |
|-------------|----------------|--|---|---|---|---|---|---------|--------------|-------------------------------|-----------|
|             |                | 1  | 2 | 3 | 4 | 5 | 6 |         |              |                               |           |
|             | E.B6.88.293    | <b>FRAME, MEMBER, ASSEMBLY</b> ... ..  |   |   |   |   |   | 1       | —            | —                             |           |
|             |                | Spares for:—   |   |   |   |   |   |         |              |                               |           |
|             | E.B6.88.251    | <b>BEAM, assembly</b> ... ..   |   |   |   |   |   | 1       | —            | —                             |           |
|             | E.B6.88.223    | <b>EYE-END, L.H.</b> ... ..  |   |   |   |   |   | 1       | S.92         | —                             |           |
|             | E.B6.88.225    | <b>EYE-END, R.H.</b> ... ..  |   |   |   |   |   | 1       | S.92         | —                             |           |
| 28M/1007404 | A27/JT         | <b>NUT, <math>\frac{3}{8}</math>" BSF</b> ... ..   |   |   |   |   |   | 1       | —            | C                             |           |
| 28M/13811   | A27/JTL        | <b>NUT, <math>\frac{3}{8}</math>" BSF</b> ... ..   |   |   |   |   |   | 1       | —            | C                             |           |
|             | E.B6.88.253    | <b>PEG, locating</b> ... ..  |   |   |   |   |   | 2       | Silver Steel | —                             |           |
|             | E.B6.88.299    | <b>PIN, locating</b> ... ..  |   |   |   |   |   | 2       | —            | —                             |           |
|             |                | Attaching parts for E.B6.88.253 and E.B6.88.299:—  |   |   |   |   |   |         |              |                               |           |
| 28M/1011467 | A27/E5         | Nut, $\frac{1}{4}$ " BSF ... ..  |   |   |   |   |   | 1       | —            | C                             |           |
| 28P/19227   | SP.90/C6       | Pin, split ... ..  |   |   |   |   |   | 1       | —            | C                             |           |
| 28W/14395   | AS.1905/E8     | Washer, saddle ... ..  |   |   |   |   |   | 2       | —            | C                             |           |
|             | E.B6.88.227    | <b>PIN, pivot</b> ... ..   |   |   |   |   |   | 4       | S.92         | —                             |           |
|             |                | Attaching parts for E.B6.88.227:—  |   |   |   |   |   |         |              |                               |           |
| 28N/5555    | AGS.899/8      | Collar ... ..  |   |   |   |   |   | 1       | —            | C                             |           |
| 28P/19175   | SP.90/E5       | Pin, split ... ..  |   |   |   |   |   | 1       | —            | C                             |           |
|             | E.B6.88.285    | <b>FRAME, "B", ALIGNMENT, GROUP</b> ... ..   |   |   |   |   |   | 1       | —            | —                             |           |
|             |                | Spares for this group are identical with those for group Pt. No. E.B6.88.283 on page 638, except for the following deletion and addition |   |   |   |   |   |         |              |                               |           |
|             |                | Delete:—   |   |   |   |   |   |         |              |                               |           |
|             | E.B6.88.287    | <b>BEAM, ASSEMBLY</b> ... ..   |   |   |   |   |   | 2       | —            | —                             |           |
|             |                | Add:—  |   |   |   |   |   |         |              |                               |           |
|             | E.B6.88.289    | <b>BEAM, ASSEMBLY</b> ... ..   |   |   |   |   |   | 2       | —            | —                             |           |
|             | —              | <b>LINE, "Luron 2", nylon mono-filament</b> ... ..   |   |   |   |   |   | QR      | —            | —                             |           |
|             | E.B6.88.255    | <b>PLATE, LOCATION</b> ... ..  |   |   |   |   |   | 1       | —            | —                             |           |
|             |                | Spares for:—   |   |   |   |   |   |         |              |                               |           |
|             | E.B6.88.259    | <b>PIN, locating</b> ... ..  |   |   |   |   |   | 2       | S.92         | —                             |           |
|             |                | Attaching parts for E.B6.88.259:—  |   |   |   |   |   |         |              |                               |           |
| 28M/9403519 | A27/BP         | Nut, 4 BA ... ..   |   |   |   |   |   | 1       | —            | C                             |           |
| 28W/9419465 | SP.13/B        | Washer ... ..  |   |   |   |   |   | 1       | —            | C                             |           |
|             | E.B6.88.239    | <b>PLUG, centre</b> ... ..   |   |   |   |   |   | 1       | S. 96        | —                             |           |
|             | E.B6.88.141    | <b>TRESTLE, assembly</b> ... ..  |   |   |   |   |   | 1       | —            | —                             |           |
| 1C/2161     | †              | <b>SCREWDRIVER</b> ... ..  |   |   |   |   |   | 1       | —            | A                             |           |
| 95277       | E.B7.88.1      | <b>SEAL, engine dust</b> ... ..  |   |   |   |   |   | 2       | —            | A                             |           |
| 95619       | E.A3.88.5053   | <b>SET, TEST, AIR VENTILATED SUIT (MOD. 4047-S.O.O.)</b>   |   |   |   |   |   | 1       | —            | A                             |           |
|             |                | Spares for:—   |   |   |   |   |   |         |              |                               |           |
|             | E.A3.88.5077   | <b>ADAPTOR, TEST GAUGE, ASSEMBLY</b> ... ..  |   |   |   |   |   | 1       | —            | —                             |           |
|             |                | Spares for:—   |   |   |   |   |   |         |              |                               |           |
|             | SAUNDERS VALVE | <b>HANDLE, manual control</b> ... ..   |   |   |   |   |   | 1       | —            | —                             |           |
|             | A.102/3        |  |   |   |   |   |   |         |              |                               |           |
|             | DUNLOP         |  |   |   |   |   |   |         |              |                               |           |
|             | DAS.412/E/10   | <b>HOSE, kinkproof, <math>\frac{5}{8}</math>" dia.</b> ... ..  |   |   |   |   |   | 1       | —            | —                             |           |
|             | E.A3.88.5085   | <b>ORIFICE, test</b> ... ..  |   |   |   |   |   | 1       | L.72         | —                             |           |
|             | DUNLOP         |  |   |   |   |   |   |         |              |                               |           |
|             | ACO.6592       | <b>PLUG, mating</b> ... ..   |   |   |   |   |   | 1       | —            | —                             |           |

**EQUIPMENT, ANCILLARY  
GROUND EQUIPMENT**

| Ref. No.   | Part No.   | Description  | No. off                              | Matl. Spec.                          | Cl. of Equip.                        |      | Plate No. |
|--|--|--|--------------------------------------|--------------------------------------|--------------------------------------|------|-----------|
|  |  |  |                                      |                                      | M.R.                                 | L.M. |           |
|  |  | 1 2 3 4 5 6  |                                      |                                      |                                      |      |           |
|  | E.A3.88.5065<br>SAUNDERS<br>VALVE<br>106 AR 02<br>BELLS ASBESTOS<br>O.S.8                                      | <b>TEE-PIECE</b> ... ..<br><b>VALVE</b> , Mk. 3, screwed, S.P. aero ... ..<br><b>WASHER</b> , sealing ... ..   | 1<br>1<br>1                          | —<br>—<br>—                          | —<br>—<br>—                          |      |           |
|  | E.A3.88.5069<br>E.A3.88.5055   | <b>ADAPTOR</b> , test gauge, assembly ... ..<br><b>CASE, CARRYING, ASSEMBLY</b> ... ..<br>Spares for:—   | 1<br>1                               | —<br>—                               | —<br>—                               |      |           |
|  | E.A3.88.5081   | <b>BAG</b> , stowage ... ..  | 1                                    | —                                    | —                                    |      |           |
|  | E.A3.88.5057<br>E.A3.88.5059<br>E.A3.88.5061<br>E.A3.88.5063   | <b>ORIFICE</b> , test ... ..<br><b>PLUG, BLANKING, ASSEMBLY</b> ... ..<br><b>PLUG, BLANKING, ASSEMBLY</b> ... ..<br><b>PLUG, BLANKING, ASSEMBLY</b> ... ..<br>Spares for:—   | 3<br>1<br>1<br>1                     | —<br>—<br>—<br>—                     | —<br>—<br>—<br>—                     |      |           |
| 21084  | E.A2.88.77   | <b>PENNANT</b> ... ..  | 1                                    | —                                    | C                                    |      |           |
| 95089  | E.A1.88.743  | <b>SLEEVE, MAIN UNDERCARRIAGE WHEEL<br/>LOCKING, GROUP</b><br>Spares for:—   | 2                                    | —                                    | A                                    |      |           |
| 21084<br>28FP/9432064  | E.A2.88.77<br>A.817  | <b>PENNANT</b> ... ..<br><b>PIN</b> , "pip" ... ..   | 2<br>2                               | —<br>—                               | C<br>C                               |      |           |
| 95008<br>95009<br>95006<br>95007<br>95457<br>95084<br>95094<br>95443 | E.A1.88.11<br>E.A1.88.59<br>E.A1.88.61<br>E.A1.88.65<br>E.A9.88.83<br>E.A1.88.601<br>E.A1.88.741<br>E.B6.88.39 | <b>SLING</b> , and frame, main plane lifting, complete ... ..<br><b>SLING</b> , tailplane ... ..<br><b>SLING</b> , centre fuselage lifting, complete ... ..<br><b>SLING</b> , rear fuselage lifting, complete ... ..<br><b>SLING</b> , front fuselage lifting, complete (Mod. 1787) ... ..<br><b>SLING</b> , fin and rudder ... ..<br><b>SLING</b> , combined, nose and mid-fuselage lifting ... ..<br><b>SLING, INTEGRAL TANKS, ASSEMBLY</b> ... ..<br>Spares for:— | 1<br>1<br>1<br>1<br>1<br>1<br>1<br>1 | —<br>—<br>—<br>—<br>—<br>—<br>—<br>— | A<br>A<br>A<br>A<br>A<br>A<br>A<br>B |      |           |
| 95479  | E.B6.88.57   | <b>EYE-BOLT</b> ... ..   | 1                                    | S.92                                 | C                                    |      |           |
| 1L/22<br>1L/45<br>1L/67  | †<br>†<br>†  | <b>SOCKET</b> , 7/8" BSF, for explosive bolts ... ..<br><b>SOCKET</b> , 3/4" BSF, for attachment bolts ... ..<br><b>SOCKET</b> , 1" BSF, for attachment bolts ... ..   | 2<br>1<br>1                          | —<br>—<br>—                          | A<br>A<br>A                          |      |           |
| 95086  | E.A3.88.135  | <b>SPANNER</b> , special, main undercarriage oleo axle clamp   | 1                                    | Steel                                | B                                    |      |           |
| 95064  | E.A1.88.263  | <b>SPANNER</b> , integral and drop tanks, drain plugs (Pre-Mod. 733)   | 1                                    | DTD.124A                             | B                                    |      |           |
| 95269<br>95264<br>95325  | E.A3.88.293<br>AS.130<br>E.A3.88.303   | <b>SPANNER</b> , wing tip tank, drain plug (Mod. 733) ... ..<br><b>SPANNER</b> , wing tip tank filler cap ... ..<br><b>SPANNER</b> , special, main undercarriage oleo bearing ring   | 1<br>1<br>1                          | —<br>—<br>Steel                      | B<br>B<br>B                          |      |           |
| 95493  | E.A1.88.877  | <b>SPANNER</b> , nosewheel door "up" lock release (Mod. 2311)  | 1                                    | —                                    | B                                    |      |           |
| 95054  | E.A1.88.345  | <b>SPANNER</b> , torque link, main undercarriage special screw   | 1                                    | DTD.124A                             | B                                    |      |           |
| 95056  | E.A1.88.347  | <b>SPANNER</b> , special "C", main undercarriage oleo stop nut   | 1                                    | —                                    | B                                    |      |           |
| 95057  | E.A1.88.353  | <b>SPANNER</b> , special, main undercarriage oleo piston   | 1                                    | —                                    | B                                    |      |           |

**EQUIPMENT, ANCILLARY  
GROUND EQUIPMENT**

| Ref. No. | Part No.                                   | Description  | No. off | Matl. Spec. | Cl. of Equip. | Plate No. |
|----------|--|--|---------|-------------|---------------|-----------|
|          |  |  |         |             | M.R. L.M.     |           |
|          |  | 1 2 3 4 5 6  |         |             |               |           |
| 95065    | E.A1.88.365                                | <b>SPANNER</b> , special, plug, forward jacking point housing  | 1       | —           | B             |           |
| 95046    | E.A1.88.379                                | <b>SPANNER</b> , universal, for attaching aileron to centre hinge bracket                                | 1       | M.S.        | B             |           |
| 95059    | E.A1.88.385                                | <b>SPANNER</b> , special, for undercarriage pivot pin ...  | 1       | M.S.        | B             |           |
| 95060    | E.A1.88.387                                | <b>SPANNER</b> , special, for undercarriage pivot nut ...  | 1       | M.S.        | B             |           |
| 95079    | E.A1.88.531                                | <b>SPANNER</b> , special, for drop tank, explosive bolt, assembly  | 1       | M.S.        | B             |           |
| 95095    | E.A1.88.749                                | <b>SPANNER</b> , forward bomb crutch ...   | 1       | —           | B             |           |
| 95466    | E.B7.88.203                                | <b>SPANNER</b> , special, fuel pump pipe, integral tank (Mod. 1730)                                      | 1       | S.3         | B             |           |
| 1C/3226  | †  | <b>SPANNER</b> , union, main fuel feed ...   | 2       | —           | B             |           |
| 95004    | E.A1.88.23                                 | <b>SPIGOT</b> , forward jacking, front fuselage ...  | 1       | L.65        | B             |           |
| 95262    | E.A3.88.273                                | <b>STRAP</b> , metal, for use with combined nose and centre fuselage sling                               | 1       | —           | B             |           |
| 95444    | E.B6.88.81                                 | <b>STRAP, INNER, INTEGRAL TANK, ASSEMBLY</b> ...<br>Spares for:—   | 1       | —           | B             |           |
| 95465    | E.B6.88.119                                | <b>BOLT</b> , sub-assembly ...   | 1       | —           | C             |           |
| 95464    | E.B6.88.121                                | <b>BOLT</b> , sub-assembly ...   | 1       | —           | C             |           |
| 95483    | E.B6.88.47                                 | <b>BRACKET</b> , guide ...   | 1       | —           | C             |           |
| 95445    | E.B6.88.83                                 | <b>STRAP</b> , outer ...   | 1       | —           | B             |           |
| 95090    | E.A1.88.799                                | <b>STRUT</b> , jury, tailplane ...   | 1       | —           | B             |           |
| 95448    | E.A9.88.529                                | <b>TEMPLATE</b> , rigging, aileron (Mod. 2184) ...   | 1       | —           | A             |           |
| 95447    | E.A9.88.527                                | <b>TEMPLATE</b> , rigging, rudder and elevator (Mod. 2184)   | 1       | —           | A             |           |
| 95061    | E.A1.88.351                                | <b>TOOL</b> , shock absorbing piston centralising ...  | 1       | —           | A             |           |
| 95062    | E.A1.88.361                                | <b>TOOL</b> , special combination, main undercarriage oleo insertion and extraction of spherical bearing | 1       | —           | A             |           |
| 95441    | TS.47-28                                   | <b>TOOL</b> , countersinking, 3/4" ...   | 1       | —           | B             |           |
| 95101    | E.A1.88.821                                | <b>TOOL</b> , setting ...  | 1       | —           | B             |           |
| 95082    | MARTIN BAKER<br>A/MBEU/80/EE<br>E.A1.88.87 | <b>TOOL</b> , for cocking and uncocking snatch unit ...  | 1       | —           | A             |           |
| 95017    | E.A1.88.87A                                | <b>TRESTLES, REAR FUSELAGE, ASSEMBLY</b> ...<br>Spares for:—<br><b>FORMER</b> , forward ...              | 1       | Spruce      | B             |           |
| 95018    | E.A1.88.87B                                | <b>FORMER</b> , aft ...  | 1       | Spruce      | B             |           |
| 95016    | E.A1.88.85                                 | <b>TROLLEY, PRESSURE CABIN, GROUND MAINTENANCE, ASSEMBLY</b><br>Spares for:—                             | 1       | —           | A             |           |
| 95487    | E.A2.88.53                                 | <b>WHEEL</b> , trolley (capowheel T.82) ...  | 4       | —           | A             |           |
| 95111    | ALVIS.18101                                | <b>TROLLEY, BOMB LOADING, HYDRAULIC, MK. 2</b><br>Spares for:—   | 1       | —           | A             |           |
| 95239    | LOCKHEED<br>HC.34501B                      | <b>ADAPTOR</b> , hose, pump, O.S. ...  | 1       | —           | B             |           |
| 95240    | HC.31723                                   | <b>ADAPTOR</b> , hose, pump lines ...  | 2       | —           | B             |           |
| 95241    | HC.24313                                   | <b>ADAPTOR</b> , tank and pump ...   | 3       | —           | B             |           |
| 95242    | HC.4968                                    | <b>ADAPTOR</b> ...   | 3       | —           | B             |           |
| 95243    | HC.27254                                   | <b>ADAPTOR</b> ...   | 4       | —           | B             |           |
| 95244    | HC.33438                                   | <b>ADAPTOR</b> , cylinder to hose ...  | 3       | —           | B             |           |
| 95155    | AS.17986                                   | <b>ADAPTOR</b> , plate (16 1/2" dia.) ...  | 8       | —           | B             |           |
| 95122    | AS.16571                                   | <b>ARM</b> , steering, O.S. ...  | 1       | —           | A             |           |

**EQUIPMENT, ANCILLARY  
GROUND EQUIPMENT**

| Ref. No.  | Part No.      | Description  |   |   |   |   |   | No. off | Matl. Spec. | Cl. of Equip.<br>M.R.<br>L.M. | Plate No. |
|-----------|---------------|--|---|---|---|---|---|---------|-------------|-------------------------------|-----------|
|           |               | 1  | 2 | 3 | 4 | 5 | 6 |         |             |                               |           |
| 95123     | AS.16572      | ARM, steering, N.S. ... ..                             |   |   |   |   |   | 1       | —           | A                             |           |
| 95249     | HC.23364      | BANJO, fitting ... ..                                  |   |   |   |   |   | 30      | —           | B                             |           |
| 95250     | HC.23367      | BANJO, fitting, double, $\frac{5}{8}$ " ... ..         |   |   |   |   |   | 8       | —           | B                             |           |
| 95251     | HC.16297      | BANJO, fitting, angle, reversing valve ... ..          |   |   |   |   |   | 1       | —           | B                             |           |
| 95252     | HC.38058      | BANJO, hose, $\frac{1}{4}$ " ... ..                    |   |   |   |   |   | 10      | —           | B                             |           |
| 95217     | AS.18151      | BEARING, assy., roller, cradle ... ..                  |   |   |   |   |   | 8       | —           | A                             |           |
| 95218     | AS.1856       | BEARING, assy., roller, store ... ..                   |   |   |   |   |   | 8       | —           | A                             |           |
| 95253     | HC.1318       | BOLT, banjo, $\frac{1}{4}$ " ... ..                    |   |   |   |   |   | 49      | —           | B                             |           |
| 95530     | HC.31727/4    | BOOT, cylinder, lifting ... ..                         |   |   |   |   |   | 1       | —           | C                             |           |
| 95531     | HC.41447      | BOOT, cylinder, lifting ... ..                         |   |   |   |   |   | 1       | —           | C                             |           |
| 95254     | NO.1331       | BOOT, for reversing valve ... ..                       |   |   |   |   |   | 1       | —           | B                             |           |
| 95118     | AS.16555      | BRAKE, drum ... ..                                     |   |   |   |   |   | 2       | —           | A                             |           |
|           | GIRLING       |  |   |   |   |   |   |         |             |                               |           |
| 16L/21880 | GB.34608      | BRAKE, assembly, R.H. ... ..                           |   |   |   |   |   | 1       | —           | A                             |           |
|           | GIRLING       |  |   |   |   |   |   |         |             |                               |           |
| 16L/21890 | GB.34609      | BRAKE, assembly, L.H. ... ..                           |   |   |   |   |   | 1       | —           | A                             |           |
| 95138     | AS.16688      | BUSH, bellcrank lever ... ..                           |   |   |   |   |   | 1       | —           | B                             |           |
| 95141     | AS.16685      | BUSH, upper brake lever spindle and valve handle shaft |   |   |   |   |   | 6       | —           | B                             |           |
|           |               |  |   |   |   |   |   |         |             |                               |           |
| 95142     | AS.16686      | BUSH, lower brake lever spindle ... ..                 |   |   |   |   |   | 2       | —           | B                             |           |
| 95144     | AS.16687      | BUSH, bisector lever ... ..                            |   |   |   |   |   | 2       | —           | B                             |           |
| 95133     | AS.16716      | BUSH, handbrake lever ... ..                           |   |   |   |   |   | 1       | —           | B                             |           |
| 95159     | AS.16981      | BUSH, reversing lever ... ..                           |   |   |   |   |   | 1       | —           | B                             |           |
| 95121     | AS.16575      | BUSH, stub axle swivel pin and lifting arm stop        |   |   |   |   |   | 8       | —           | B                             |           |
| 95146     | AS.16684      | BUSH, spindle, brake lever ... ..                      |   |   |   |   |   | 2       | —           | B                             |           |
| 95128     | AS.16591      | BUSH, tow bar yoke and plate ... ..                    |   |   |   |   |   | 4       | —           | B                             |           |
| 95151     | AS.16569      | BUSH, tilting cylinder pin ... ..                      |   |   |   |   |   | 2       | —           | B                             |           |
| 95152     | AS.16816      | BUSH, long, transmitter shaft ... ..                   |   |   |   |   |   | 2       | —           | B                             |           |
| 95153     | AS.16817      | BUSH, short, transmitter shaft ... ..                  |   |   |   |   |   | 2       | —           | B                             |           |
| 95157     | AS.16987      | BUSH, store roller ... ..                              |   |   |   |   |   | 4       | —           | B                             |           |
| 95131     | AS.17263      | CATCH, trigger, tow bar ... ..                         |   |   |   |   |   | 1       | —           | B                             |           |
| 95255     | K.20109       | CLIP, for boot ... ..                                  |   |   |   |   |   | 1       | —           | B                             |           |
| 95219     | HC.41412      | CYLINDER, lifting ... ..                               |   |   |   |   |   | 2       | —           | B                             |           |
| 95220     | HC.31392J     | CYLINDER, lifting ... ..                               |   |   |   |   |   | 2       | —           | B                             |           |
| 95221     | HC.25220.QC.4 | CYLINDER, TABLE OPERATING, 4" STROKE ASSEMBLY          |   |   |   |   |   | 2       | —           | B                             |           |
|           |               | Spares for:—   |   |   |   |   |   |         |             |                               |           |
|           | HC.26357/8    | BOOT, c/w clip and filter assembly ... ..              |   |   |   |   |   | 1       | —           | —                             |           |
| 95222     | HC.25220.NJ.6 | CYLINDER, table operating, 6" stroke ... ..            |   |   |   |   |   | 2       | —           | A                             |           |
| 16T/770   | NO.6358       | EXTENSION, valve ... ..                                |   |   |   |   |   | 4       | —           | B                             |           |
| 95226     | MF.2604       | FILTER, micronic ... ..                                |   |   |   |   |   | 1       | —           | B                             |           |
|           | or            |  |   |   |   |   |   |         |             |                               |           |
|           | MF.2629       | FILTER, micronic ... ..                                |   |   |   |   |   | 1       | —           | —                             |           |
| 95247     | HC.36961      | FITTING, bulkhead ... ..                               |   |   |   |   |   | 26      | —           | B                             |           |
| 16L/8300  | 15489         | FITTING, bulkhead ... ..                               |   |   |   |   |   | 8       | —           | C                             |           |
| 16L/10800 | KL.44524      | GASKET, for banjo ... ..                               |   |   |   |   |   | 54      | —           | C                             |           |
| 95257     | KL.44521      | GASKET ... ..  |   |   |   |   |   | 70      | —           | B                             |           |
| 95258     | KL.44528      | GASKET, $\frac{3}{8}$ " ... ..                         |   |   |   |   |   | 8       | —           | B                             |           |
| 95259     | KL.44535      | GASKET, $\frac{1}{2}$ " ... ..                         |   |   |   |   |   | 8       | —           | B                             |           |
| 95225     | HC.2107A      | HANDWHEEL ... ..                                       |   |   |   |   |   | 2       | —           | B                             |           |
| 95230     | CM.323.B.12   | HOSE, pump and tank, N.S. and O.S., 12" long ... ..    |   |   |   |   |   | 3       | —           | B                             |           |
| 95231     | CM.374.D.18   | HOSE, pump and tank, N.S., 18" long ... ..             |   |   |   |   |   | 1       | —           | B                             |           |
| 95232     | CM.374.D.24   | HOSE, pump and tank, O.S., 24" long ... ..             |   |   |   |   |   | 1       | —           | B                             |           |
| 95233     | CM.322.B.19   | HOSE, lifting cylinder and hydroloc. O.S. 19" long     |   |   |   |   |   | 8       | —           | B                             |           |
| 95234     | CM.323.B.24   | HOSE, lifting cylinder, 24" long ... ..                |   |   |   |   |   | 4       | —           | B                             |           |
| 95235     | CM.322.B.42   | HOSE, table cylinder ... ..                            |   |   |   |   |   | 1       | —           | B                             |           |

**EQUIPMENT, ANCILLARY  
GROUND EQUIPMENT**

| Ref. No. | Part No.    | Description |   |  |     |     |     | No. off | Matl. Spec. | Cl. of Equip. |      | Plate No. |
|----------|-------------|-------------|---|--|-----|-----|-----|---------|-------------|---------------|------|-----------|
|          |             | 1           | 2   | 3  | 4   | 5   | 6   |         |             | M.R.          | L.M. |           |
| 95236    | CM.322.B.34 | HOSE,       | table   | cylinder                                 | ... | ... | ... | 1       | —           |               | B    |           |
| 95237    | CM.322.B.41 | HOSE,       | table   | cylinder                                 | ... | ... | ... | 1       | —           |               | B    |           |
| 95238    | CM.322.B.32 | HOSE,       | table   | cylinder                                 | ... | ... | ... | 1       | —           |               | B    |           |
| 95124    | AS.16573    | KEY,        | steering  | arm                                      | ... | ... | ... | 2       | —           |               | B    |           |
| 95126    | AS.16595    | LOCKNUT,    | steering  | arm tie rod socket, R.H.                 | ... | ... | ... | 2       | —           |               | B    |           |
| 95127    | AS.16596    | LOCKNUT,    | steering  | arm tie rod socket, L.H.                 | ... | ... | ... | 2       | —           |               | B    |           |
| 16L/9752 | 18234       | NUT,        | tube,   | $\frac{5}{16}$ "                         | ... | ... | ... | 114     | —           |               | C    |           |
| 95256    | NO.19885    | NUT,        | tube  | ...                                      | ... | ... | ... | 6       | —           |               | B    |           |
| 95117    | AS.16438    | NUT,        | wheel   | ...                                      | ... | ... | ... | 32      | —           |               | B    |           |
| 16M/1478 | HC.1787     | OUTLET,     | straight  | ...                                      | ... | ... | ... | 10      | —           |               | C    |           |
| 95245    | HC.14028    | OUTLET,     | straight,   | tank                                     | ... | ... | ... | 1       | —           |               | B    |           |
| 95136    | AS.16751    | PAWL,       | handbrake   | ...                                      | ... | ... | ... | 1       | —           |               | B    |           |
| 16L/2460 | 1234        | PIECE,      | 3-way,  | $\frac{1}{8}$ " pipe                     | ... | ... | ... | 5       | —           |               | C    |           |
| 95248    | HC.40504    | PIECE,      | 3-way,  | pump line N.S.                           | ... | ... | ... | 1       | —           |               | B    |           |
| 95154    | AS.17039    | PIN,        | hinge,  | transmitter bracket                      | ... | ... | ... | 2       | —           |               | B    |           |
| 28FP/647 | A.1013      | PIN,        | "pip"   | ...                                      | ... | ... | ... | 2       | —           |               | C    |           |
| 95134    | AS.16715    | PIN,        | pivot,  | handbrake lever                          | ... | ... | ... | 1       | —           |               | B    |           |
| 95139    | AS.16675    | PIN,        | pivot,  | bellcrank lever                          | ... | ... | ... | 1       | —           |               | B    |           |
| 95148    | AS.16892    | PIN,        | pivot,  | 22" long, lifting cylinder               | ... | ... | ... | 2       | —           |               | B    |           |
| 95149    | AS.16800    | PIN,        | pivot,  | 8 $\frac{1}{4}$ " long, lifting cylinder | ... | ... | ... | 2       | —           |               | B    |           |
| 95150    | AS.16568    | PIN,        | pivot,  | lifting cylinder                         | ... | ... | ... | 2       | —           |               | B    |           |
| 95120    | AS.16574    | PIN,        | stub axle swivel (front) and lifting arm stop           | ...                                      | ... | ... | ... | 4       | —           |               | B    |           |
| 95129    | AS.16592    | PIN,        | swivel,   | tow bar yoke                             | ... | ... | ... | 1       | —           |               | B    |           |
| 95130    | AS.16594    | PIN,        | swivel,   | tow bar                                  | ... | ... | ... | 1       | —           |               | B    |           |
| 95161    | AS.17187    | PIPE,       | tank to tee piece                                       | ...                                      | ... | ... | ... | 1       | —           |               | B    |           |
| 95162    | AS.17188    | PIPE,       | hose adaptor to filter, N.S.                            | ...                                      | ... | ... | ... | 1       | —           |               | B    |           |
| 95163    | AS.17189    | PIPE,       | tank to hose, N.S.                                      | ...                                      | ... | ... | ... | 1       | —           |               | B    |           |
| 95164    | AS.17191    | PIPE,       | 3-way to pump, N.S.                                     | ...                                      | ... | ... | ... | 1       | —           |               | B    |           |
| 95165    | AS.17192    | PIPE,       | pump to hose, N.S.                                      | ...                                      | ... | ... | ... | 1       | —           |               | B    |           |
| 95166    | AS.17193    | PIPE,       | pump to hose, O.S.                                      | ...                                      | ... | ... | ... | 1       | —           |               | B    |           |
| 95167    | AS.17194    | PIPE,       | reversing valve to selector valve                       | ...                                      | ... | ... | ... | 1       | —           |               | B    |           |
| 95168    | AS.17195    | PIPE,       | 3-way to reversing valve, N.S.                          | ...                                      | ... | ... | ... | 1       | —           |               | B    |           |
| 95169    | AS.17196    | PIPE,       | O.S. pump hose to 3-way, N.S.                           | ...                                      | ... | ... | ... | 1       | —           |               | B    |           |
| 95170    | AS.17197    | PIPE,       | 3-way to hose adaptor, N.S.                             | ...                                      | ... | ... | ... | 1       | —           |               | B    |           |
| 95171    | AS.17202    | PIPE,       | filter to reversing valve                               | ...                                      | ... | ... | ... | 1       | —           |               | B    |           |
| 95172    | AS.17203    | PIPE,       | reversing valve to selector valve                       | ...                                      | ... | ... | ... | 1       | —           |               | B    |           |
| 95173    | AS.17204    | PIPE,       | bracket to selector valve                               | ...                                      | ... | ... | ... | 1       | —           |               | B    |           |
| 95174    | AS.17205    | PIPE,       | bracket to selector valve                               | ...                                      | ... | ... | ... | 1       | —           |               | B    |           |
| 95175    | AS.17206    | PIPE,       | bracket to selector valve                               | ...                                      | ... | ... | ... | 1       | —           |               | B    |           |
| 95176    | AS.17207    | PIPE,       | bracket to selector valve                               | ...                                      | ... | ... | ... | 1       | —           |               | B    |           |
| 95177    | AS.17208    | PIPE,       | bracket to N.S. bracket                                 | ...                                      | ... | ... | ... | 1       | —           |               | B    |           |
| 95178    | AS.17209    | PIPE,       | O.S. bracket to N.S. bracket                            | ...                                      | ... | ... | ... | 1       | —           |               | B    |           |
| 95179    | AS.17210    | PIPE,       | O.S. bracket to N.S. bracket                            | ...                                      | ... | ... | ... | 1       | —           |               | B    |           |
| 95180    | AS.17211    | PIPE,       | O.S. bracket to N.S. bracket                            | ...                                      | ... | ... | ... | 1       | —           |               | B    |           |
| 95181    | AS.17212    | PIPE,       | hydroloc valve to hydroloc valve (Arm)                  | ...                                      | ... | ... | ... | 2       | —           |               | B    |           |
| 95182    | AS.17213    | PIPE,       | hydroloc valve to hydroloc valve (Arm)                  | ...                                      | ... | ... | ... | 2       | —           |               | B    |           |
| 95183    | AS.17216    | PIPE,       | No. 1, hydroloc valve (Arm) to bracket, O.S.            | ...                                      | ... | ... | ... | 1       | —           |               | B    |           |
| 95184    | AS.17217    | PIPE,       | No. 2, hydroloc valve (Arm) to bracket, O.S.            | ...                                      | ... | ... | ... | 1       | —           |               | B    |           |
| 95185    | AS.17218    | PIPE,       | No. 3, hydroloc valve (Arm) to bracket, O.S.            | ...                                      | ... | ... | ... | 1       | —           |               | B    |           |
| 95186    | AS.17219    | PIPE,       | No. 4, hydroloc valve (Arm) to bracket, O.S.            | ...                                      | ... | ... | ... | 1       | —           |               | B    |           |
| 95187    | AS.17220    | PIPE,       | No. 1, hydroloc valve (on Arm) to bracket (on Arm) O.S. | ...                                      | ... | ... | ... | 1       | —           |               | B    |           |

**EQUIPMENT, ANCILLARY  
GROUND EQUIPMENT**

| Ref. No. | Part No.    | Description  | No. off | Matl. Spec. | Cl. of Equip. |      | Plate No. |
|----------|-------------|--|---------|-------------|---------------|------|-----------|
|          |             |  |         |             | M.R.          | L.M. |           |
|          |             | 1 2 3 4 5 6  |         |             |               |      |           |
| 95188    | AS.17221    | PIPE, No. 2, hydroloc (on Arm) to bracket (on Arm) O.S.  | 1       | —           |               | B    |           |
| 95189    | AS.17222    | PIPE, No. 3, hydroloc (on Arm) to bracket (on Arm) O.S.  | 1       | —           |               | B    |           |
| 95190    | AS.17223    | PIPE, No. 4, hydroloc (on Arm) to bracket (on Arm) O.S.  | 1       | —           |               | B    |           |
| 95191    | AS.17224    | PIPE, jack to jack (Forward & Aft)                       | 1       | —           |               | B    |           |
| 95192    | AS.17225    | PIPE, jack to jack (Forward & Aft)                       | 1       | —           |               | B    |           |
| 95193    | AS.17226    | PIPE, jack to jack (Lateral)                             | 1       | —           |               | B    |           |
| 95194    | AS.17227    | PIPE, jack to jack (Lateral)                             | 1       | —           |               | B    |           |
| 95195    | AS.17228    | PIPE, hydroloc valve (top) to 3-way, rear end            | 1       | —           |               | B    |           |
| 95196    | AS.17229    | PIPE, hydroloc valve (top) to 3-way, rear end            | 1       | —           |               | B    |           |
| 95197    | AS.17230    | PIPE, pump hose adaptor, O.S. to pump hose adaptor, N.S. | 1       | —           |               | B    |           |
| 95198    | AS.17231    | PIPE, reversing valve to selector valve                  | 1       | —           |               | B    |           |
| 95199    | AS.17232    | PIPE, bracket to 3-way                                   | 2       | —           |               | B    |           |
| 95200    | AS.17233    | PIPE, bracket to 3-way                                   | 2       | —           |               | B    |           |
| 95201    | AS.17234    | PIPE, hydroloc valve (top) to bracket, N.S.              | 1       | —           |               | B    |           |
| 95202    | AS.17235    | PIPE, hydroloc valve (top) to bracket, N.S.              | 1       | —           |               | B    |           |
| 95203    | AS.17236    | PIPE, selector valve to bracket                          | 1       | —           |               | B    |           |
| 95204    | AS.17237    | PIPE, selector valve to bracket                          | 1       | —           |               | B    |           |
| 95205    | AS.17238    | PIPE, centre to bottom, hydroloc valve                   | 1       | —           |               | B    |           |
| 95206    | AS.17239    | PIPE, centre, hydroloc valve to 3-way                    | 1       | —           |               | B    |           |
| 95207    | AS.17240    | PIPE, bracket to 3-way, N.S.                             | 1       | —           |               | B    |           |
| 95208    | AS.17241    | PIPE, bracket to 3-way, N.S.                             | 1       | —           |               | B    |           |
| 95209    | AS.17242    | PIPE, hydroloc valve (bottom) to bracket, N.S.           | 1       | —           |               | B    |           |
| 95210    | AS.17243    | PIPE, centre to bottom hydroloc valve                    | 1       | —           |               | B    |           |
| 95211    | AS.17244    | PIPE, bottom hydroloc valve to 3-way                     | 1       | —           |               | B    |           |
| 95212    | AS.17245    | PIPE, bracket, O.S. to 3-way                             | 1       | —           |               | B    |           |
| 95213    | AS.17246    | PIPE, bracket, O.S. to 3-way                             | 1       | —           |               | B    |           |
| 95214    | AS.17247    | PIPE, hydroloc valve (centre) to bracket, N.S.           | 1       | —           |               | B    |           |
| 95215    | AS.17248    | PIPE, selector valve to bracket, N.S.                    | 1       | —           |               | B    |           |
| 95216    | AS.17249    | PIPE, selector valve to bracket, N.S.                    | 1       | —           |               | B    |           |
| 95246    | HCP.16902   | PLUG, pump   | 2       | —           |               | B    |           |
| 95224    | HC.26140.F  | PUMP, transmitter  | 2       | —           |               | A    |           |
| 95135    | AS.16245    | QUADRANT, handbrake                                      | 1       | —           |               | B    |           |
| 95125    | AS.16577    | ROD, tie, steering                                       | 2       | —           |               | B    |           |
| 95119    |             | SEAL, oil, hub (Burtonwood No. 275-350)                  | 4       | —           |               | B    |           |
| 95467    | AS.18003/2  | SEAL, felt   | 8       | —           |               | C    |           |
| 95158    | AS.17006    | SHAFT, store roller                                      | 4       | —           |               | B    |           |
| 95160    | AS.17934    | SHAFT, valve handle                                      | 2       | —           |               | B    |           |
| 95260    | J.3704 R.H. | SOCKET, assembly steering tie rod, R.H.                  | 2       | —           |               | B    |           |
| 95261    | J.3705 L.H. | SOCKET, assembly, steering tie rod, L.H.                 | 2       | —           |               | B    |           |
| 95140    | AS.16678    | SPINDLE, brake lever                                     | 2       | —           |               | B    |           |
| 95143    | AS.16671    | SPINDLE, bisector lever                                  | 1       | —           |               | B    |           |
| 95145    | AS.16683    | SPINDLE, brake lever                                     | 2       | —           |               | B    |           |
| 95147    | N.1738      | SPRING, brake return                                     | 2       | —           |               | B    |           |
| 95156    | AS.3729     | SPRING, cradle retaining pin trigger                     | 4       | —           |               | B    |           |
| 95137    | N.1464      | SPRING, handbrake trigger rod                            | 1       | —           |               | B    |           |
| 95132    | AS.17271    | SPRING, tow bar catch                                    | 1       | —           |               | B    |           |
| 95116    | AS.16437    | STUD, wheel  | 32      | —           |               | B    |           |
| 95223    | HC.42544    | TANK, supply   | 1       | —           |               | B    |           |
| 16T/768  |             | TUBE, inner  | 4       | —           |               | A    |           |
| 16T/767  |             | TYRE, standard tread, 10 ply, 7"x9"                      | 4       | —           |               | A    |           |

**EQUIPMENT, ANCILLARY  
GROUND EQUIPMENT**

| Ref. No.  | Part No.       | Description   | No. off | Matl. Spec. | Cl. of Equip. | Plate No. |
|-----------|----------------|---|---------|-------------|---------------|-----------|
|           |                |   |         |             | M.R. L.M.     |           |
|           |                | 1 2 3 4 5 6   |         |             |               |           |
| 95227     | HC.19694A      | VALVE, hydroloc ... ..  | 7       | —           | B             |           |
| 95228     | HC.28085.S     | VALVE, reversing ... ..   | 1       | —           | A             |           |
| 95229     | HC.42197       | VALVE, ROTARY SELECTOR, 4-WAY ...                                       | 1       | —           | B             |           |
|           |                | Spares for:—  |         |             |               |           |
| 95648     | HC.42237       | SEAL ... ..   | 1       | —           | C             |           |
| 16T/766   | WDM.685        | WHEEL, road, 4"33 x 9" ... ..   | 4       | —           | A             |           |
| 95263     | ALVIS AS.18152 | TROLLEY, POWER PACK ... ..<br>(For use with Ref. 95111)<br>Spares for:— | 1       | —           | A             |           |
| 95356     | ALVIS AS.18126 | ADAPTOR, control valve ... ..   | 1       | —           | B             |           |
|           | LOCKHEED       |   |         |             |               |           |
| 95239     | HC.34501/B     | ADAPTOR, 1/4" x 1/4" ... ..   | 1       | —           | B             |           |
| 95373     | HC.34501/C     | ADAPTOR, 3/8" x 3/8" ... ..   | 1       | —           | B             |           |
| 95241     | HC.24313       | ADAPTOR ... ..  | 2       | —           | B             |           |
| 95243     | HC.27254       | ADAPTOR ... ..  | 1       | —           | B             |           |
| 95387     | HC.35563       | ADAPTOR, 3/4" BSF x 3/8" BSP ... ..                                     | 1       | —           | B             |           |
| 95388     | HC.23709       | ADAPTOR, 1/8" BSF x 3/8" BSP ... ..                                     | 1       | —           | B             |           |
| 95389     | HC.34502/CB    | ADAPTOR, hose, 3/8" BSP x 1/4" BSP ...                                  | 2       | —           | B             |           |
| 95383     | HC.22379       | BANJO, 3/4" ... ..  | 3       | —           | B             |           |
| 95390     | NO.236         | BANJO, 1/4" ... ..  | 1       | —           | B             |           |
| 95253     | HC.1318        | BOLT, banjo ... ..  | 4       | —           | B             |           |
| 95365     | ALVIS AS.18360 | BUCKLE-END, strap ... ..  | 4       | —           | B             |           |
| 95344     | AS.18119       | CAP, support leg ... ..   | 4       | —           | B             |           |
|           | LOCKHEED       |   |         |             |               |           |
| 27BA/8794 | AVA.63/C       | CAP, blanking, 3/8" ... ..  | 1       | —           | B             |           |
| 27BA/8826 | AVA.63/B       | CAP, blanking, 1/4" ... ..  | 1       | —           | B             |           |
| 95394     | HC.1000        | CLIP, pipe, 1/4" double ... ..  | 2       | —           | B             |           |
| 95395     | HC.2449        | CLIP, pipe, 3/8" single ... ..  | 2       | —           | B             |           |
| 95348     | ALVIS AS.18143 | CLIP, spring, roof ... ..   | 2       | —           | B             |           |
|           | LOCKHEED       |   |         |             |               |           |
| 95381     | HC.42472       | CONNECTION, 3-way, 1/4" ... ..  | 1       | —           | B             |           |
| 95385     | HC.11835       | CONNECTION, 3-way, 3/8" ... ..  | 1       | —           | B             |           |
| 27BA/8759 | AVA.57/B       | COUPLING, Avery, 1/4" half union, pressure line                         | 1       | —           | B             |           |
| 27BA/8760 | AVA.57/C       | COUPLING, Avery, 3/8" half union, return line ...                       | 1       | —           | B             |           |
| 95361     | ALVIS AS.18354 | COVER, L.H. ... ..  | 1       | Canvas      | B             |           |
| 95362     | AS.18355       | COVER, R.H. ... ..  | 1       | Canvas      | B             |           |
| 95363     | AS.18356       | COVER, front ... ..   | 1       | —           | B             |           |
| 42L/      | —              | ENGINE, Villiers, Mk. 25, with reduction gear S.5309                    | 1       | —           | A             |           |
|           | LOCKHEED       |   |         |             |               |           |
| 95367     | HC.44240       | FITTING, bulkhead, 1/4" ... ..  | 1       | —           | B             |           |
| 95368     | HC.44242       | FITTING, bulkhead, 3/8" ... ..  | 1       | —           | B             |           |
| 95257     | KL.44521       | GASKET, 1/4" BSP ... ..   | 9       | —           | B             |           |
| 16L/10800 | KL.44524       | GASKET, banjo ... ..  | 4       | —           | B             |           |
| 95258     | KL.44528       | GASKET, 3/8" BSP ... ..   | 6       | —           | B             |           |
| 95391     | KL.44523       | GASKET, 9/16" BSF ... ..  | 1       | —           | B             |           |
| 95392     | KL.44532       | GASKET, 1/4" BSF ... ..   | 1       | —           | B             |           |
| 95259     | KL.44535       | GASKET, 1/2" BSP ... ..   | 1       | —           | B             |           |
| 95393     | KL.44543       | GASKET, 3/4" ... ..   | 2       | —           | B             |           |
|           | WAINE          |   |         |             |               |           |
| 95346     | W.O.1928       | HANDLE, roof ... ..   | 2       | —           | B             |           |
|           | LOCKHEED       |   |         |             |               |           |
| 95376     | CM.3258/240    | HOSE, 1/2" H.P., 20' long, pressure line ...                            | 1       | —           | B             |           |

**EQUIPMENT, ANCILLARY  
GROUND EQUIPMENT**

| Ref. No. | Part No.       | Description  | No. off | Matl. Spec. | Cl. of Equip. |      | Plate No. |
|----------|----------------|--|---------|-------------|---------------|------|-----------|
|          |                |  |         |             | M.R.          | L.M. |           |
|          |                | 1 2 3 4 5 6  |         |             |               |      |           |
| 95377    | CM.373C/240    | HOSE, $\frac{3}{8}$ " , 20' long, return line ... ..   | 1       | —           |               |      | B         |
| 95378    | CM.374F/18     | HOSE, $\frac{3}{4}$ " , 18" long, pump suction ... ..  | 1       | —           |               |      | B         |
| 95379    | CM.326B/11     | HOSE, $\frac{1}{4}$ " , 11" long, pump delivery ... ..   | 1       | —           |               |      | B         |
| 95354    | ALVIS AS.18113 | LUG, and base, assembly, foot pedal ... ..   | 1       | —           |               |      | B         |
| 95343    | AS.18124       | NUT, support leg ... ..  | 4       | —           |               |      | B         |
|          | LOCKHEED       |  |         |             |               |      |           |
| 95369    | HCP.11505      | NUT, for $\frac{3}{8}$ " bulkhead fitting ... ..   | 1       | —           |               |      | B         |
| 95370    | KL.46002       | NUT, for $\frac{1}{4}$ " bulkhead fitting ... ..   | 1       | —           |               |      | B         |
| 95380    | HC.2446        | OUTLET, straight, $\frac{3}{8}$ " ... ..   | 2       | —           |               |      | B         |
| 95382    | HC.2060        | OUTLET, straight, $\frac{1}{4}$ " ... ..   | 1       | —           |               |      | B         |
| 95384    | HC.14027       | OUTLET, straight, $\frac{3}{8}$ " ... ..   | 1       | —           |               |      | B         |
| 95352    | ALVIS AS.18118 | PEDAL, foot, assembly, c/w pad ... ..  | 1       | —           |               |      | B         |
| 95347    | AS.18139       | PIN, roof hinge ... ..   | 2       | —           |               |      | B         |
| 95353    | AS.18121       | PIN, joint, pedal and control valve adaptor ...  | 2       | —           |               |      | B         |
| 95399    | AS.18326       | PIPE, control valve to 3-way, $\frac{1}{4}$ " o/d. x 20 SWG<br>x 13" long, c/w nuts                                  | 1       | —           |               |      | B         |
| 95400    | AS.18327       | PIPE, 3-way to relief valve, $\frac{1}{4}$ " o/d. x 20 SWG<br>x 29" long, c/w nuts                                   | 1       | —           |               |      | B         |
| 95401    | AS.18328       | PIPE, 3-way to bulkhead fitting, $\frac{1}{4}$ " o/d. x 20 SWG<br>x 24" long, c/w nuts                               | 1       | —           |               |      | B         |
| 95402    | AS.18329       | PIPE, tank to bulkhead fitting, $\frac{3}{8}$ " o/d. x 18 SWG<br>x 22" long, c/w nuts                                | 1       | —           |               |      | B         |
| 95403    | AS.18330       | PIPE, tank to relief valve, $\frac{3}{8}$ " o/d. x 18 SWG x 18"<br>long, c/w nuts                                    | 1       | —           |               |      | B         |
| 95404    | AS.18331       | PIPE, relief valve, to 3-way, $\frac{3}{8}$ " o/d. x 18 SWG x<br>29 $\frac{1}{2}$ " long, c/w nuts                   | 1       | —           |               |      | B         |
| 95405    | AS.18332       | PIPE, 3-way to control valve banjo, $\frac{3}{8}$ " o/d. x 18<br>SWG x 11" long, c/w nuts                            | 1       | —           |               |      | B         |
| 95406    | AS.18333       | PIPE, 3-way, to control valve outlet connection,<br>$\frac{3}{8}$ " o/d. x 18 SWG x 3 $\frac{1}{2}$ " long, c/w nuts | 1       | —           |               |      | B         |
| 95349    | AS.18142       | PLATE, roof, spring clip ... ..  | 2       | —           |               |      | B         |
|          | LOCKHEED       |  |         |             |               |      |           |
| 95386    | HCP.16901      | PLUG, $\frac{1}{4}$ " BSP ... ..   | 1       | —           |               |      | B         |
| 95360    | FP.7508        | PUMP, fluid ... ..   | 1       | —           |               |      | B         |
| 95345    | ALVIS AS.18133 | ROOF, plate, assembly, complete ... ..   | 1       | —           |               |      | B         |
|          | LOCKHEED       |  |         |             |               |      |           |
| 95396    | K.17603        | SCREW, self tapping, pipe clip ... ..  | 8       | —           |               |      | C         |
| 95350    | ALVIS AS.18144 | STOWAGE, bin ... ..  | 1       | —           |               |      | B         |
| 95364    | AS.18357       | STRAP, for cover ... ..  | 5       | —           |               |      | B         |
| 95342    | AS.18125       | STUD, support leg ... ..   | 4       | —           |               |      | C         |
| 95341    | AS.18116       | SUPPORT, leg, assembly ... ..  | 4       | —           |               |      | B         |
|          | LOCKHEED       |  |         |             |               |      |           |
| 95357    | HC.29615       | TANK, fluid supply, 3 gallon ... ..  | 1       | —           |               |      | B         |
| 95359    | HC.26260D      | VALVE, blow-off ... ..   | 1       | —           |               |      | B         |
| 95358    | HC.28085U      | VALVE, control (mechanically operated) ... ..  | 1       | —           |               |      | B         |
| 95366    | ALVIS AS.18359 | WASHER, cap ... ..   | 15      | —           |               |      | C         |
|          | LOCKHEED       |  |         |             |               |      |           |
| 95371    | K.19210        | WASHER, spring, for $\frac{1}{4}$ " bulkhead fitting ... ..  | 1       | —           |               |      | C         |
| 95372    | K.19213        | WASHER, spring, for $\frac{3}{8}$ " bulkhead fitting ... ..  | 1       | —           |               |      | C         |
| 95340    | ALVIS AS.18120 | WHEEL, and axle, assembly, c/w tyre 14 x 3-9   | 2       | —           |               |      | A         |

**EQUIPMENT, ANCILLARY  
GROUND EQUIPMENT**

| Ref. No.  | Part No.       | Description  |   |   |   |   |   | No. off | Matl. Spec. | Cl. of Equip. |      | Plate No. |
|-----------|----------------|--|---|---|---|---|---|---------|-------------|---------------|------|-----------|
|           |                | 1  | 2 | 3 | 4 | 5 | 6 |         |             | M.R.          | L.M. |           |
|           | —              | <b>TROLLEY, BOMB LOADING, CONVERSION SET ...</b>   |   |   |   |   |   | —       | —           | —             |      |           |
|           |                | Spares for:—   |   |   |   |   |   |         |             |               |      |           |
|           | LOCKHEED       |  |   |   |   |   |   |         |             |               |      |           |
|           | 33438          | <b>ADAPTOR</b> ... ..  |   |   |   |   |   | 5       | —           | B             |      |           |
| 95244     | 33438          | <b>ADAPTOR</b> ... ..  |   |   |   |   |   | 5       | —           | B             |      |           |
| 95249     | HC.23364       | <b>BANJO</b> , $\frac{1}{8}$ " pipe ... ..   |   |   |   |   |   | 4       | —           | B             |      |           |
| 95383     | HC.22379       | <b>BANJO</b> , $\frac{3}{8}$ " pipe ... ..   |   |   |   |   |   | 1       | —           | B             |      |           |
| 95253     | HC.1318        | <b>BOLT</b> , banjo ... ..   |   |   |   |   |   | 5       | —           | C             |      |           |
| 95323     | ALVIS AS.18233 | <b>BRACKET</b> , Avery coupling ... ..   |   |   |   |   |   | 1       | —           | B             |      |           |
| 95324     | AS.18234       | <b>BRIDGE</b> , protector ... ..   |   |   |   |   |   | 1       | —           | B             |      |           |
|           | AS.18239       | <b>BRIDGE</b> , protector (Made from AS.17724, Stores Ref. 95339 with one $\frac{3}{8}$ " dia. hole) |   |   |   |   |   | 1       | —           | —             |      |           |
|           | LOCKHEED       |  |   |   |   |   |   |         |             |               |      |           |
| 27M/8832  | AVA.64/B       | <b>CAP</b> , blanking, $\frac{1}{4}$ " ... ..  |   |   |   |   |   | 1       | —           | C             |      |           |
| 27M/8775  | AVA.64/C       | <b>CAP</b> , blanking, $\frac{3}{8}$ " ... ..  |   |   |   |   |   | 1       | —           | C             |      |           |
| 27M/8899  | AVA.58/B       | <b>COUPLING</b> , Avery, fixed half, $\frac{1}{4}$ " pressure line ...                               |   |   |   |   |   | 1       | —           | C             |      |           |
| 27M/8750  | AVA.55/C       | <b>COUPLING</b> , Avery, fixed half, $\frac{3}{8}$ " return line ...                                 |   |   |   |   |   | 1       | —           | C             |      |           |
|           | HC.20402       | <b>FITTING</b> , outlet, $\frac{5}{16}$ " pipe, $\frac{1}{4}$ " BSP ... ..                           |   |   |   |   |   | 3       | —           | —             |      |           |
| 95382     | HC.2060        | <b>FITTING</b> , outlet, $\frac{1}{4}$ " pipe, $\frac{1}{4}$ " BSP ... ..                            |   |   |   |   |   | 1       | —           | B             |      |           |
| 95257     | ALVIS KL.44521 | <b>GASKET</b> , $\frac{1}{4}$ " BSP ... ..   |   |   |   |   |   | 9       | —           | C             |      |           |
| 16L/10800 | KL.44524       | <b>GASKET</b> , banjo ... ..   |   |   |   |   |   | 5       | —           | C             |      |           |
|           | LOCKHEED       |  |   |   |   |   |   |         |             |               |      |           |
| 27M/      | AVX/273        | <b>OLIVE</b> , $\frac{1}{4}$ " ... ..  |   |   |   |   |   | 1       | —           | —             |      |           |
| 27M/8983  | AVX/265        | <b>OLIVE</b> , $\frac{3}{8}$ " ... ..  |   |   |   |   |   | 1       | —           | C             |      |           |
| 16L/2460  | No.1234        | <b>PIECE</b> , 3-way ... ..  |   |   |   |   |   | 1       | —           | B             |      |           |
| 95330     | ALVIS AS.18361 | <b>PIPE</b> , $\frac{5}{8}$ " o/d. x 42" long ... ..   |   |   |   |   |   | 1       | —           | B             |      |           |
| 95331     | AS.18362       | <b>PIPE</b> , $\frac{5}{8}$ " o/d. x 16" long ... ..   |   |   |   |   |   | 1       | —           | B             |      |           |
| 95332     | AS.18363       | <b>PIPE</b> , $\frac{5}{8}$ " o/d. x 13" long ... ..   |   |   |   |   |   | 1       | —           | B             |      |           |
| 95333     | AS.18364       | <b>PIPE</b> , $\frac{5}{8}$ " o/d. x 11" long ... ..   |   |   |   |   |   | 1       | —           | B             |      |           |
| 95334     | AS.18365       | <b>PIPE</b> , $\frac{5}{8}$ " o/d. x 10" long ... ..   |   |   |   |   |   | 1       | —           | B             |      |           |
| 95335     | AS.18366       | <b>PIPE</b> , $\frac{5}{8}$ " o/d. x 5" long ... ..  |   |   |   |   |   | 1       | —           | B             |      |           |
| 95336     | AS.18367       | <b>PIPE</b> , $\frac{1}{4}$ " o/d. x 12 $\frac{1}{2}$ " long ... ..                                  |   |   |   |   |   | 1       | —           | B             |      |           |
| 95337     | AS.18368       | <b>PIPE</b> , $\frac{3}{8}$ " o/d. x 13 $\frac{1}{2}$ " long ... ..                                  |   |   |   |   |   | 1       | —           | B             |      |           |
|           | LOCKHEED       |  |   |   |   |   |   |         |             |               |      |           |
| 95338     | HC.44871       | <b>RESTRICTOR</b> ... ..   |   |   |   |   |   | 2       | —           | A             |      |           |
| 16L/9752  | 18234          | <b>TUBE</b> , nut, $\frac{5}{16}$ " ... ..   |   |   |   |   |   | 14      | —           | C             |      |           |
| 27M/4699  | ADS.174A       | <b>TUBE</b> , nut, $\frac{1}{4}$ " ... ..  |   |   |   |   |   | 1       | —           | C             |      |           |
| 27M/4310  | ADS.174E       | <b>TUBE</b> , nut, $\frac{3}{8}$ " ... ..  |   |   |   |   |   | 1       | —           | C             |      |           |
|           | 239            | <b>TUBE</b> , nut, $\frac{1}{4}$ " ... ..  |   |   |   |   |   | 1       | —           | —             |      |           |
|           | 31385          | <b>TUBE</b> , nut, $\frac{3}{8}$ " ... ..  |   |   |   |   |   | 1       | —           | —             |      |           |
| 95326     | HC.44213       | <b>VALVE</b> , change over ... ..  |   |   |   |   |   | 1       | —           | A             |      |           |
| 95327     | HC.26907       | <b>VALVE</b> , non-return ... ..   |   |   |   |   |   | 1       | —           | A             |      |           |
| 1C/6239   |                | <b>WRENCH</b> , torque, for attachment bolts ... ..  |   |   |   |   |   | 1       | —           | A             |      |           |
| 1C/6447   |                | <b>WRENCH</b> , torque, pilot's canopy ... ..  |   |   |   |   |   | 1       | —           | A             |      |           |

Restricted

| Ref. No. | Part No. |   |   |   |   |   |   | No. off | Matl. Spec. | Cl. of Equip. | Plate No. |
|----------|----------|---|---|---|---|---|---|---------|-------------|---------------|-----------|
|          |          | 1 | 2 | 3 | 4 | 5 | 6 |         |             | M.R.<br>L.M.  |           |
|          |          |   |   |   |   |   |   |         |             |               |           |

**EQUIPMENT, ANCILLARY  
GROUND EQUIPMENT**

| Ref. No.  | Part No. | 1 | 2 | 3 | 4 | 5 | 6 | Description  | No. off | Matl. Spec. | Cl. of Equip. |      | Plate No. |
|---|----------|---|---|---|---|---|---|--|---------|-------------|---------------|------|-----------|
|   |          |   |   |   |   |   |   |  |         |             | M.R.          | L.M. |           |
| <b>TRANSPORTATION EQUIPMENT</b> ... ..  |          |   |   |   |   |   |   |  |         |             |               |      |           |
| 95279   |          |   |   |   |   |   |   | <b>BEAM</b> , transportation, fuselage nose (43G/SAL/180)                  | 1       | Deal        |               | B    |           |
| 95280   |          |   |   |   |   |   |   | <b>BEAM</b> , transportation, mid section, front fuselage (43G/SAL/180)    | 1       | Deal        |               | B    |           |
| 95281   |          |   |   |   |   |   |   | <b>BEAM</b> , transportation, fuselage, rear section (rear) (43G/SAL/181)  | 1       | Deal        |               | B    |           |
| 95282   |          |   |   |   |   |   |   | <b>BEAM</b> , transportation, fuselage, rear section (front) (43G/SAL/181) | 1       | Deal        |               | B    |           |
| 95285   |          |   |   |   |   |   |   | <b>BEAM</b> , transportation, fuselage, mid-section, (rear) (43G/SAL/182)  | 1       | Ash         |               | B    |           |
| 95289   |          |   |   |   |   |   |   | <b>BEAM</b> , transportation, main plane, outer, port (43G/SAL/194)        | 1       | Ash         |               | B    |           |
| 95290   |          |   |   |   |   |   |   | <b>BEAM</b> , transportation, main plane, outer, starboard (43G/SAL/194)   | 1       | Ash         |               | B    |           |
| 95291   |          |   |   |   |   |   |   | <b>BEAM</b> , transportation, (support blocks) main plane (43G/SAL/195)    | 2       | R.S.J.      |               | B    |           |
| 95286   |          |   |   |   |   |   |   | <b>BLOCK</b> , transportation, main plane, front (43G/SAL/185)             | 2       | Ash         |               | B    |           |
| 95287   |          |   |   |   |   |   |   | <b>BLOCK</b> , transportation, main plane, rear (43G/SAL/185)              | 2       | Ash         |               | B    |           |
| 95288   |          |   |   |   |   |   |   | <b>BLOCK</b> , transportation, main plane, centre (43G/SAL/185)            | 2       | Ash         |               | B    |           |
| 95283   |          |   |   |   |   |   |   | <b>PEDESTAL</b> , transportation, tail plane (43G/SAL/183)                 | 1       | M.S.        |               | B    |           |
| 95284   |          |   |   |   |   |   |   | <b>PEDESTAL</b> , transportation, tail plane (43G/SAL/183)                 | 2       | M.S.        |               | B    |           |
| NOTE:— The number off shown is the quantity required for the transportation of one aircraft |          |   |   |   |   |   |   |  |         |             |               |      |           |

Restricted

| Ref. No. | Part No. |   |   |   |   |   |   | Description | No. off | Matl. Spec. | Cl. of Equip. | Plate No. |
|----------|----------|---|---|---|---|---|---|-------------|---------|-------------|---------------|-----------|
|          |          | 1 | 2 | 3 | 4 | 5 | 6 |             |         |             | M.R.<br>L.M.  |           |
|          |          |   |   |   |   |   |   |             |         |             |               |           |

**Pages 651 to 660 not issued**



**EQUIPMENT, ANCILLARY  
GROUND EQUIPMENT**

| Ref. No.   | Part No.         | Description                                 | No. off | Matl. Spec. | Cl. of Equip. | Plate No. |
|--|------------------|---|---------|-------------|---------------|-----------|
|  |                  |   |         |             | M.R. L.M.     |           |
| 1 2 3 4 5 6  |                  |   |         |             |               |           |
| <b>SUMMARY OF STOCK ITEMS USED ON GROUND EQUIPMENT, ASSEMBLY</b> |                  |   |         |             |               |           |
| 28D/9133012  | A25/3C           | Bolt, 2 BA, hex. head, 3/4" long ... ..     |         |             |               | C         |
| 28D/1200119  | A25/4C           | Bolt, 2 BA, hex. head, "85 long ... ..      |         |             |               | C         |
| 28D/1215085  | AS.1246/12 1/2 C | Bolt, 2 BA, round head, 1-"65 long ... ..   |         |             |               | C         |
| 28D/1214258  | AS.1248/28B      | Bolt, 4 BA, mushroom head, 3-"15 long       |         |             |               | C         |
| 28D/1212801  | AS.1248/10C      | Bolt, 2 BA, mushroom head, 1-"4 long ... .. |         |             |               | C         |
| 28M/9403519  | A27/BP           | Nut, 4 BA, plain ... ..                     |         |             |               | C         |
| 28M/1006473  | A27/CT           | Nut, 2 BA, thin ... ..                      |         |             |               | C         |
| 28M/1011467  | A27/ES           | Nut, 1/4" BSF, slotted ... ..               |         |             |               | C         |
| 28M/1007403  | A27/ET           | Nut, 1/4" BSF, thin ... ..                  |         |             |               | C         |
| 28M/1007404  | A27/JT           | Nut, 3/8" BSF, thin ... ..                  |         |             |               | C         |
| 28M/13811  | A27/JTL          | Nut, 3/8" BSF, thin, L.H. ... ..            |         |             |               | C         |
| 28M/10327  | AGS.2002/B/1     | Nut, stiff, 4 BA ... ..                     |         |             |               | C         |
| 28P/19227  | SP.90/C6         | Pin, split, 1/16" dia. x 7/8" long ... ..   |         |             |               | C         |
| 28P/19176  | SP.90/G6         | Pin, split, 1/8" dia. x 1" long ... ..      |         |             |               | C         |
| 28P/9528015  | SP.90/G8         | Pin, split, 1/8" dia. x 1 1/4" long ... ..  |         |             |               | C         |
| 28S/9995324  | A24/A16          | Screw, 6 BA, round head, 1/2" long ... ..   |         |             |               | C         |
| 28W/9419465  | SP.13/B          | Washer, 4 BA, plain ... ..                  |         |             |               | C         |
| 28W/9419466  | SP.13/J          | Washer, 3/8" BSF, plain ... ..              |         |             |               | C         |
| 28W/9419468  | SP.13/N          | Washer, 1/2" BSF, plain ... ..              |         |             |               | C         |
| 28W/9419475  | SP.15/C          | Washer, 2 BA, plain ... ..                  |         |             |               | C         |
| 28W/14395  | AS.1905/E8       | Washer, 1/4" BSF, saddle ... ..             |         |             |               | C         |

| Ref. No. | Part No. | 1 2 3 4 5 6 |  |  |  |  |  | No. off | Matl. Spec. | Cl. of Equip.<br>M.R.<br>L.M. | Plate No. |
|----------|----------|-------------|--|--|--|--|--|---------|-------------|-------------------------------|-----------|
|          |          |             |  |  |  |  |  |         |             |                               |           |
|          |          |             |  |  |  |  |  |         |             |                               |           |

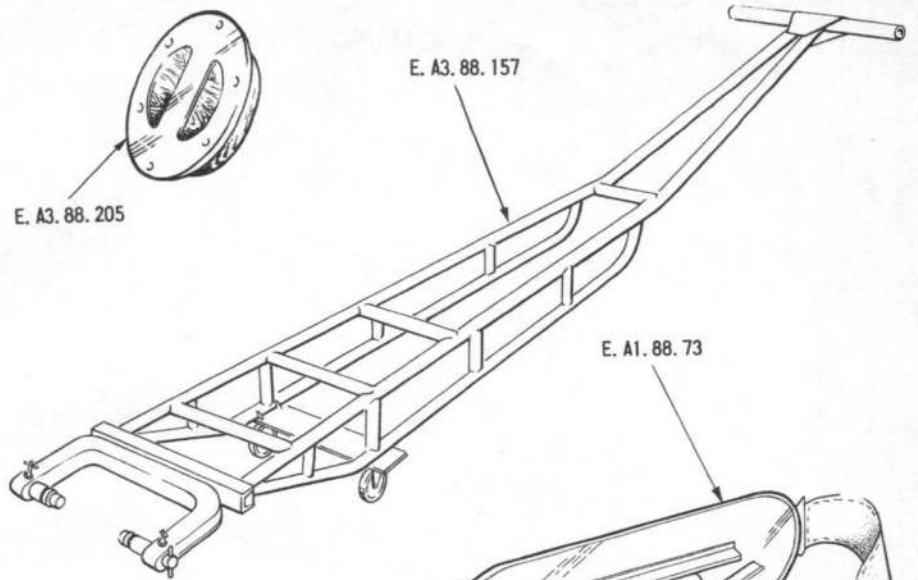
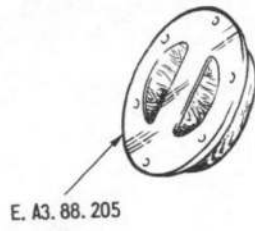
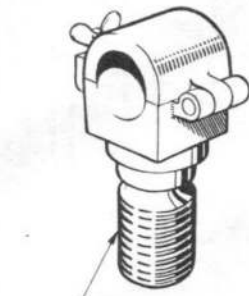

E. A1. 88. 73

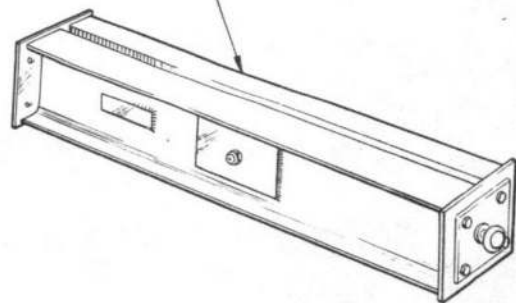
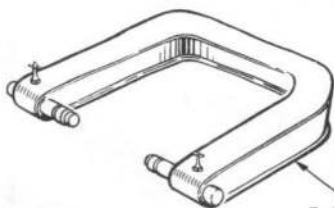
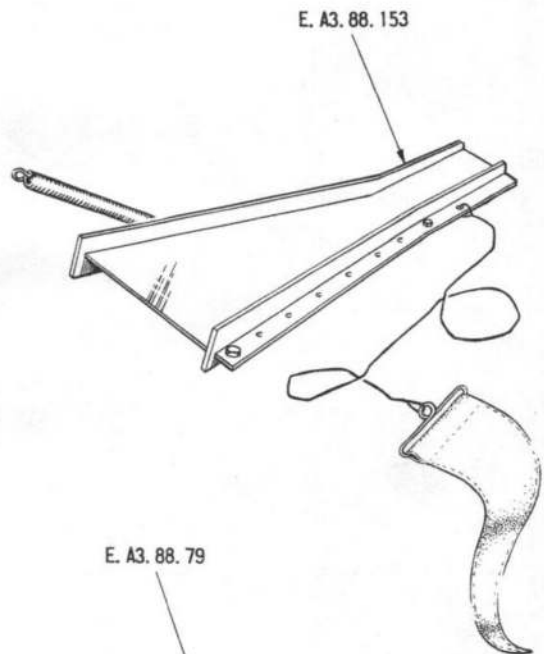
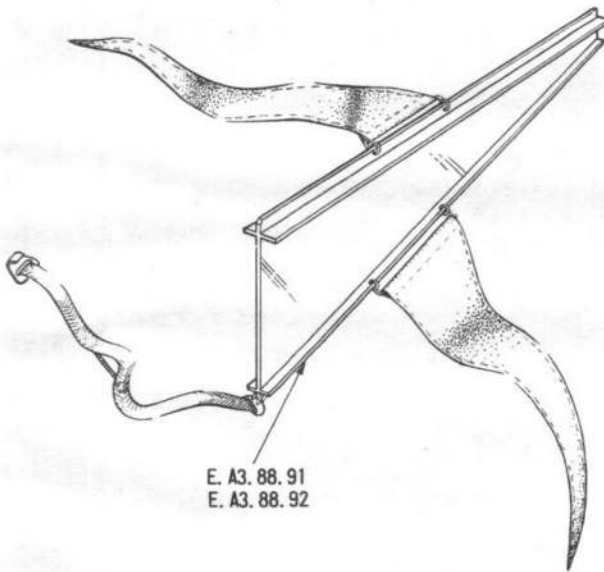
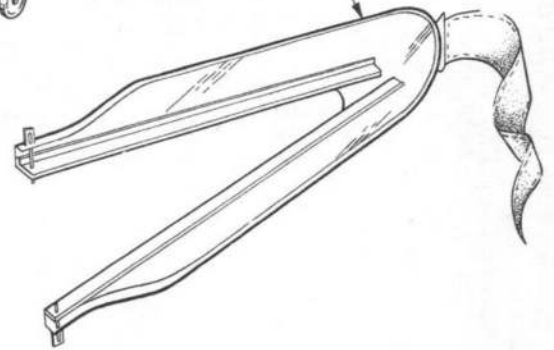



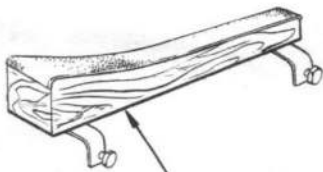
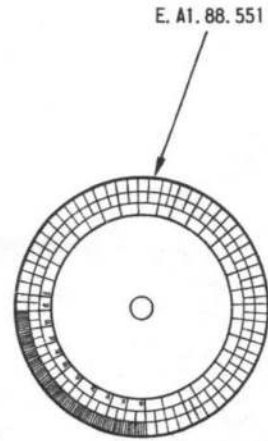
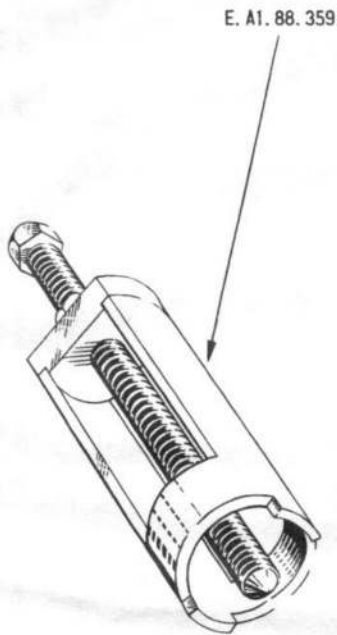
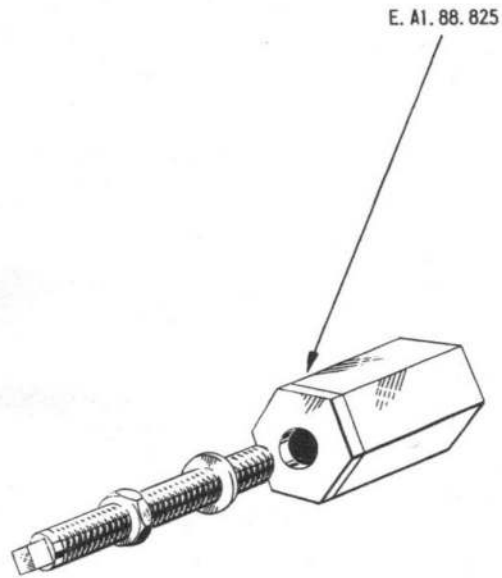
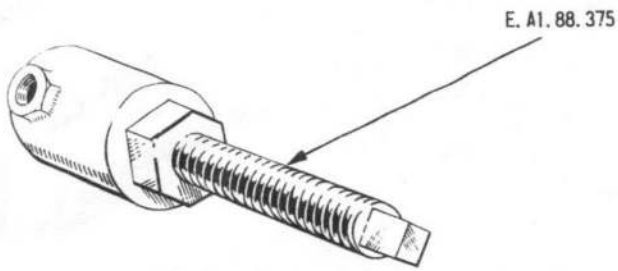

INBOARD { E. A1. 88. 91A  
E. A1. 88. 92A  
OUTBOARD { E. A1. 88. 91D  
E. A1. 88. 92D

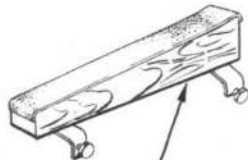

INBOARD { E. A1. 88. 91B  
E. A1. 88. 92B  
OUTBOARD { E. A1. 88. 91E  
E. A1. 88. 92E

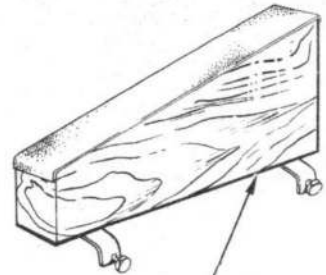

INBOARD { E. A1. 88. 91C  
E. A1. 88. 92C  
OUTBOARD { E. A1. 88. 91F  
E. A1. 88. 92F

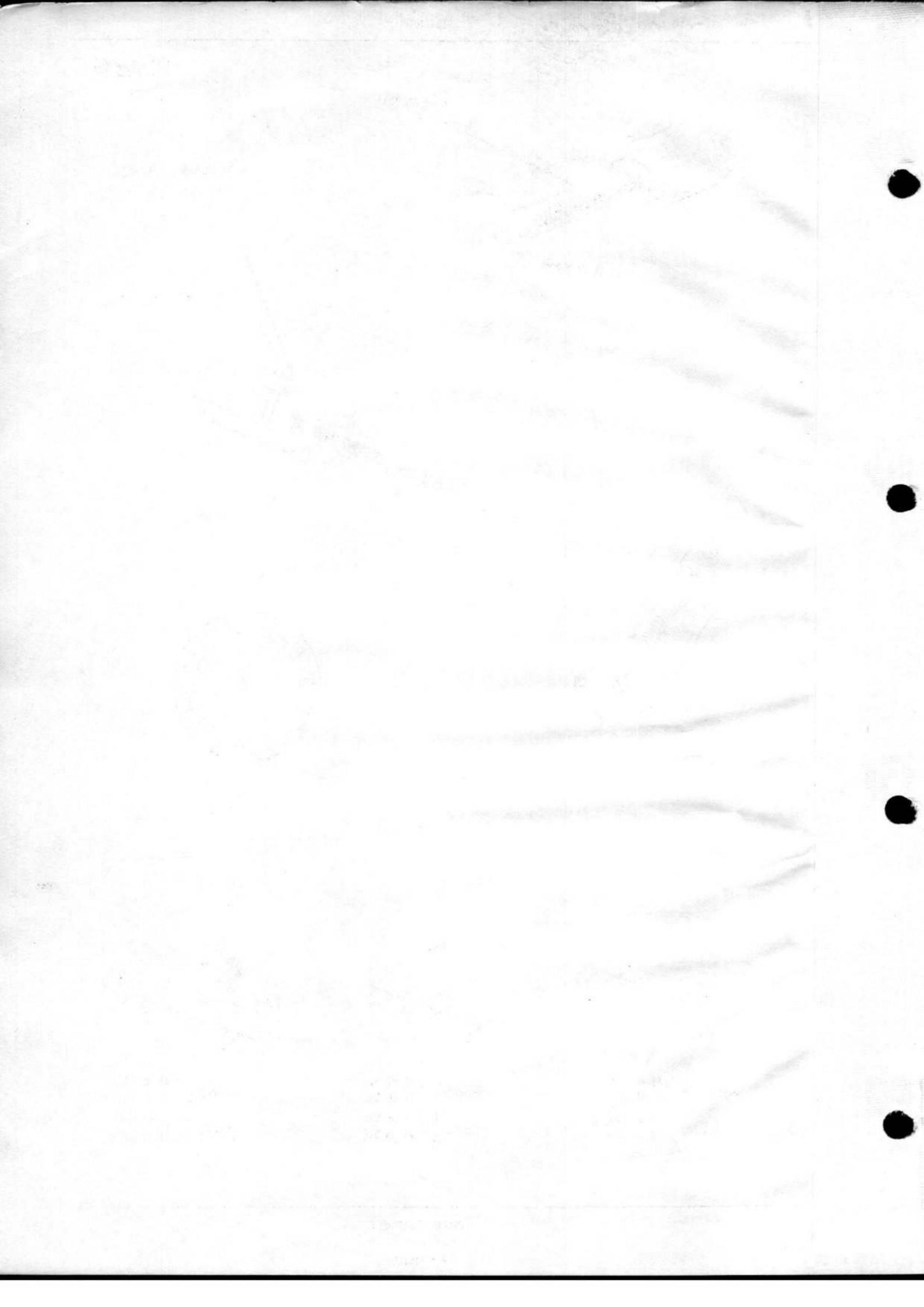

This file was downloaded  
from the RTFM Library.

Link: [www.scottbouch.com/rtfm](http://www.scottbouch.com/rtfm)

Please see site for usage terms,  
and more aircraft documents.

