

## Chapter 14

### MAGNETIC SWITCHES (ROTAX D8700 SERIES)

#### LIST OF CONTENTS

|                            | <i>Para.</i> |                            | <i>Para.</i> |
|----------------------------|--------------|----------------------------|--------------|
| <i>Introduction</i> ... .. | 1            | <b>Functioning</b> ... ..  | 9            |
| <b>Description</b> ... ..  | 2            | <b>Installation</b> ... .. | 13           |

#### LIST OF ILLUSTRATIONS

|   | <i>Fig.</i> |  | <i>Fig.</i> |
|---|-------------|--|-------------|
| <i>General view of a typical series D8700 switch</i> ... .. | 1           | <i>Sectional view of a typical unit</i> ... .. | 2           |
|   |             | <i>Wiring diagram of a typical unit</i> ... .. | 3           |

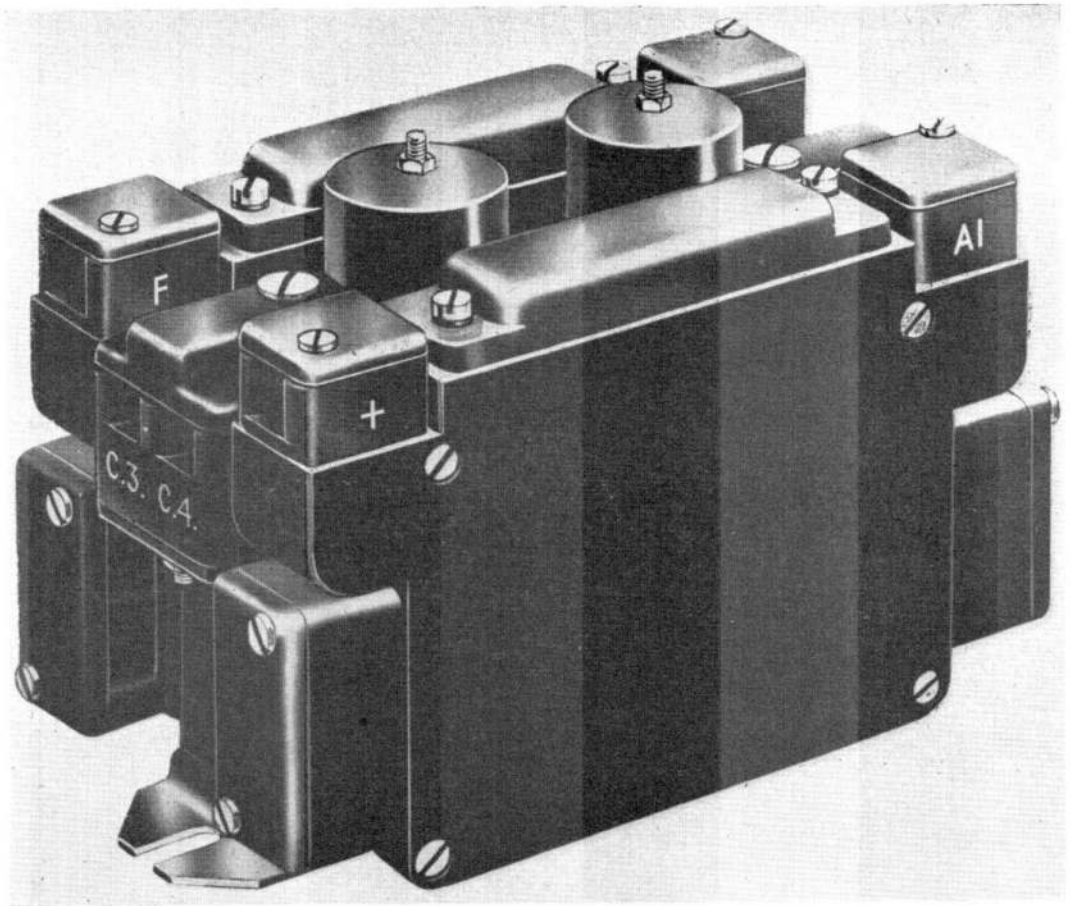

Fig. 1. General view of a typical series D8700 switch

## Introduction

1. Magnetic switches in the D8700 series are designed for use in 112-volt d.c. installations. They serve as double pole reversing contactors and are short rated. The main purpose of these switch units is to provide current flow in either direction as required, e.g., to effect reversal of direction of an actuator motor.

## DESCRIPTION

2. The types of switch in the range are similar in design, differing only in their rating and arrangement of contacts. For details of specific types reference should be made to A.P.4343C, Vol. 1, Book 2, Sect. 4. Each unit comprises a light alloy casting which houses the actuating and interlocking mechanism. Two operating solenoids, with their associated terminals blocks, are mounted on the top and end faces respectively. Two moulded switch housings containing the main and auxiliary or shunt field contacts are fitted to the opposite side faces.

3. The main terminal post assemblies and the auxiliary or shunt field terminal blocks are fitted to and mounted externally on their respective switch housings.

4. Easily removable covers are fitted over the main contacts and to the switch housings to facilitate access for inspection and servicing purposes.

5. A mounting plate with two slots, the centres of which are spaced 4.2 in. apart to take 2 B.A. fixing bolts, is fitted to the main casting of the D8701 and D8704 inclusive; the slot centres are spaced 5.3 in. apart in the D8710 to D8713 inclusive, the size of the bolts remaining the same throughout the series.

6. A more detailed view of a typical unit in the series is given in fig. 2, which shows the general arrangement of the components.

7. Separate pairs of contacts are employed for each direction of rotation, with an interlocking mechanism provided to prevent

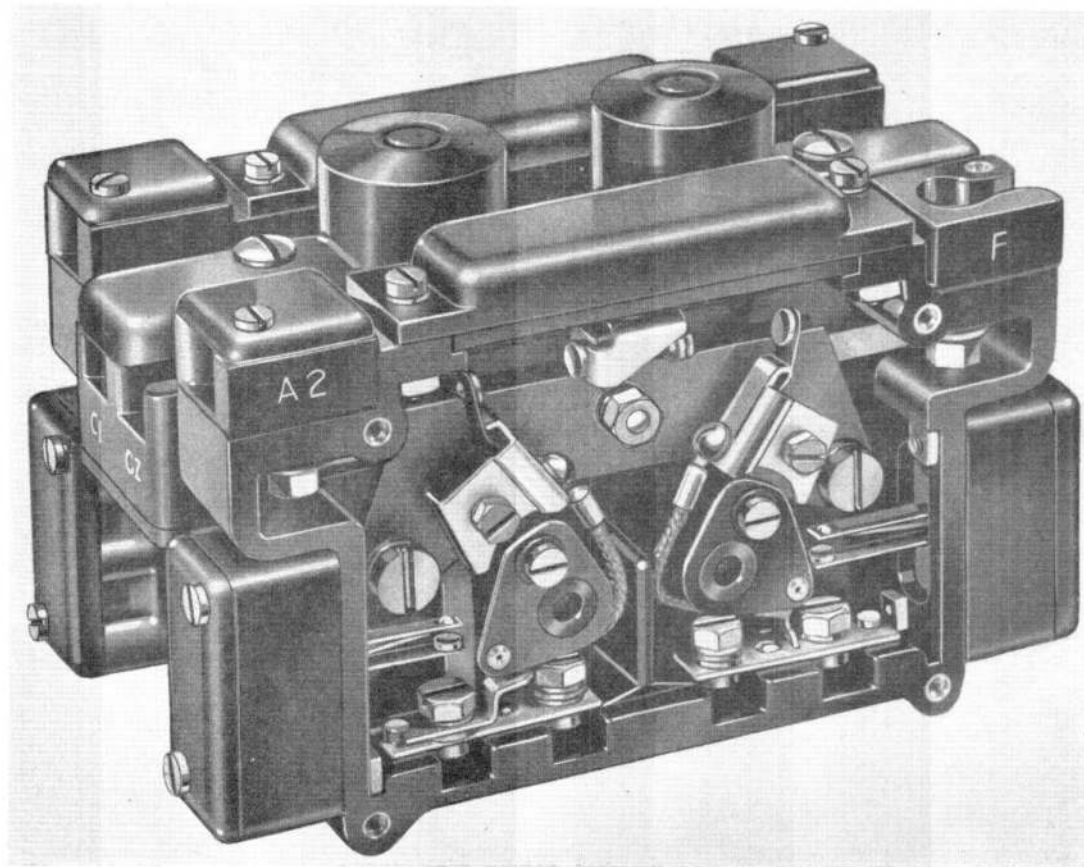

Fig. 2. Sectional view of a typical unit

**RESTRICTED**

simultaneous operation of both sets of contacts. The main contacts are short rated at 5 to 15 amp., and the shunt field and auxiliary contacts at 2.5 amp.

8. Electrical connections are made via the 2 B.A. terminal posts and the externally mounted terminal blocks fitted with 4 B.A. combined screw and washer terminals.

#### FUNCTIONING

9. When either of the solenoids is energized, the magnetic pull created on its plunger will cause it, against the pressure of the return springs, to be drawn towards the core. This movement is transmitted, via the actuating levers and the main contact carrier driving shafts, to operate the respective main and associated shunt field and auxiliary contacts.

10. When the energizing current through the solenoid is broken, the plungers, under pressure from the return springs, are returned to the rest position, causing at the same time, via the actuating mechanism, the contacts to be returned to their normal positions.

11. Operation of the interlocking mechanism is such that, in addition to preventing the simultaneous closing of both sets of contacts if both coils are inadvertently operated together, it ensures that, in the event of one pair of contacts becoming locked in the ON position, the circuit will be interrupted by the other pair of contacts when the operating solenoid is de-energized. These contacts cannot be closed until the interlock mechanism is manually unlatched.

12. The shunt field contacts are so arranged that the polarity of the associated motor shunt winding remains the same with either solenoid operated, i.e., remains constant irrespective of the direction of armature current.

#### INSTALLATION

13. Full installation details may be obtained from the relevant Aircraft Handbook, but mounting in any position, except with the base plate uppermost, is permissible to facilitate convenient wiring and inspection.

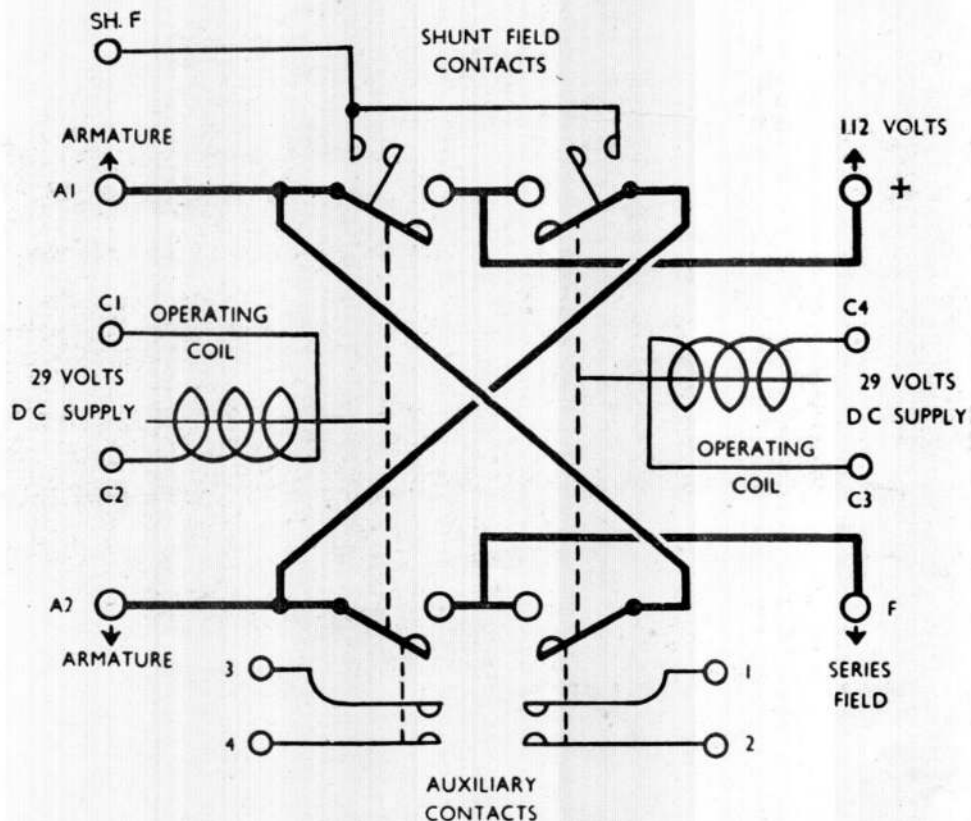
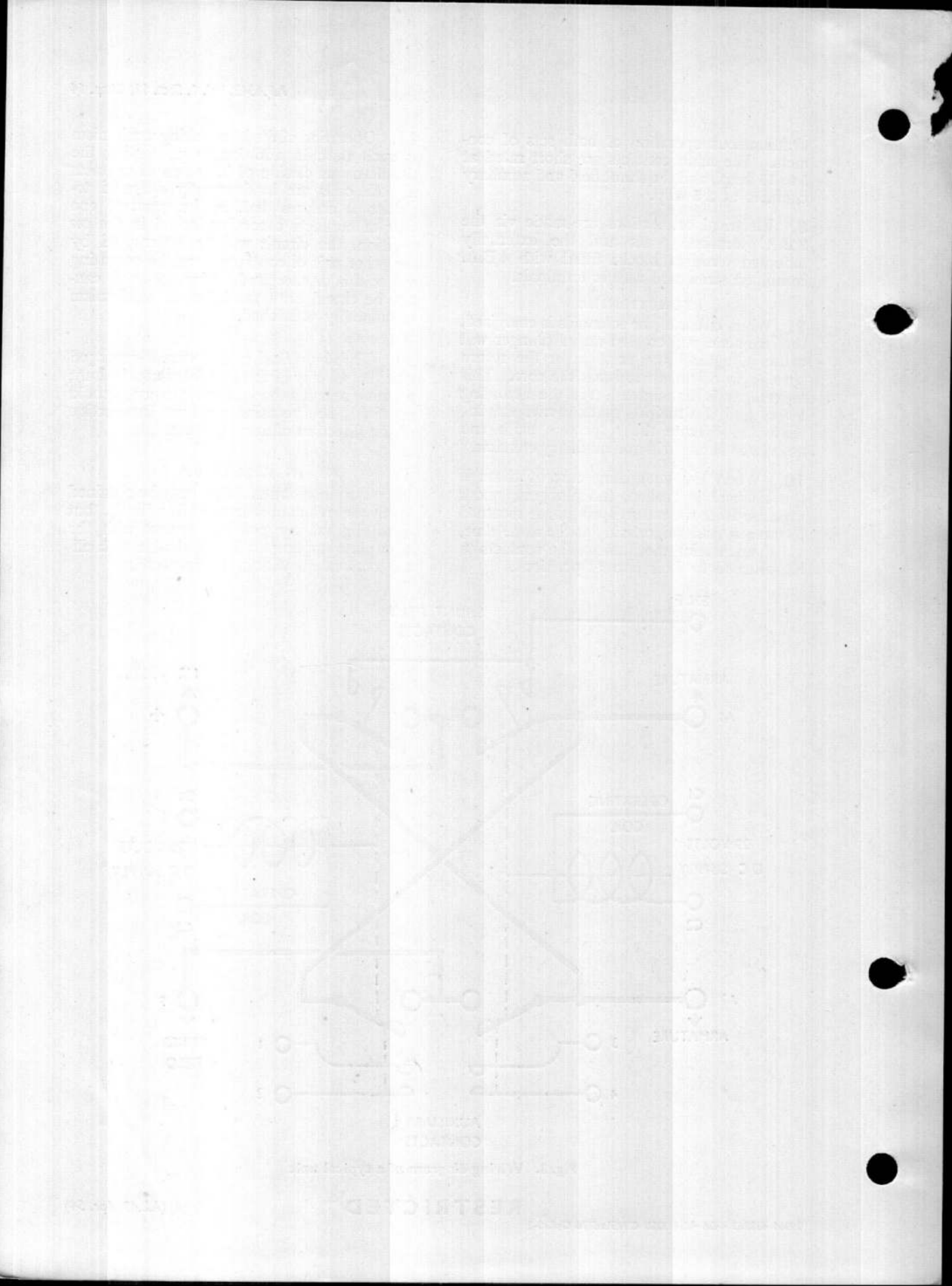

Fig. 3. Wiring diagram of a typical unit

**RESTRICTED**

(A.L.49, Apr. 54)



This file was downloaded  
from the RTFM Library.

Link: [www.scottbouch.com/rtfm](http://www.scottbouch.com/rtfm)

Please see site for usage terms,  
and more aircraft documents.

