

Chapter 9

PUMP, FUEL, BP SERIES

LIST OF CONTENTS

	Para.		Para.
<i>Introduction</i>	1	<i>Fuel sealing glands</i>	10
<i>Description</i>	2	<i>Electrical connection</i>	11
<i>Driving motor</i>	3	<i>Operation</i>	12
<i>Pump body</i>	8	<i>Installation</i>	13
<i>Pump base</i>	9	<i>Servicing</i>	17

LIST OF ILLUSTRATIONS

	Fig.
<i>Sectional view of BP type pump</i>	1

Introduction

1. The BP group of pumps are electrically driven, fuel booster pumps supplying fuel under pressure to the aircraft engine-driven pump under conditions of fuel temperature, de-aeration, and vapour formation at high altitudes. In addition, the pump may be used to transfer fuel from auxiliary to main tanks.

DESCRIPTION

2. Each type of pump is designed for mounting within the fuel tank, being completely immersed in fuel, except for the electrical connection, the gland drains, and the fuel delivery outlet, which are to atmosphere. Some pumps, though of the same group, may vary in design according to requirements, but usually they comprise three main sub-assemblies, namely, the driving motor and casing, the pump body, and the pump base.

Driving motor

3. The driving motor is usually of the two-pole, compound-wound, flame-proof, totally enclosed type and is designed to operate either on a nominal 24-volt d.c. or 112-volt d.c.

4. The armature and commutator are mounted on a shaft or spindle which rotates, supported in ball bearings. The bearings are packed with high melting, low freezing point grease and are suitably shielded.

5. An extension of the armature spindle passes through a fuel sealing gland to the impeller chamber, where it terminates in a machined end to receive the impeller assembly.

6. The field windings are shrunk into the motor casing, which is secured by screws to the upper flange of the pump body.

7. The brushgear is of unit construction with the brush boxes secured to the bakelite carrier, and the complete unit is retained in position by screws which also secure the spring contact assembly to the closed end of the motor casing.

Pump body

8. The pump body houses the fuel sealing gland which is around the armature shaft, or

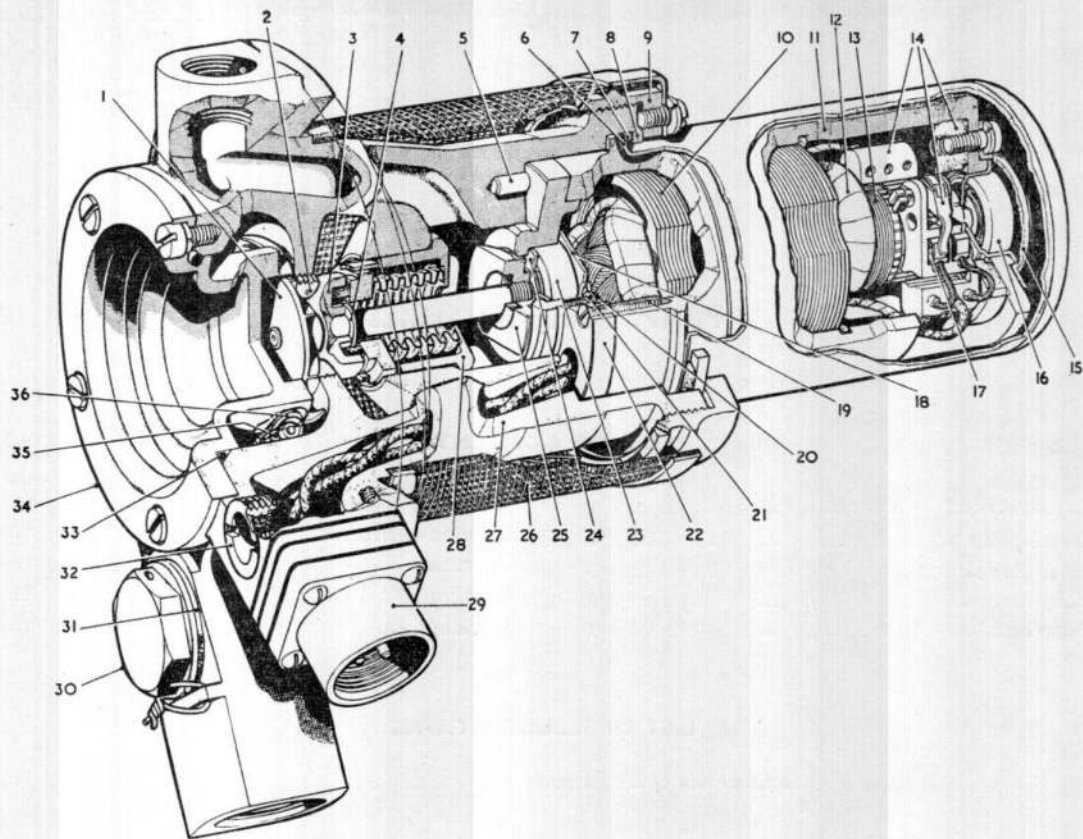

- | | | |
|---------------------------|------------------------------------|------------------------|
| 1 IMPELLER | 13 ARMATURE | 25 THROWER RING |
| 2 IMPELLER ADJUSTING RING | 14 BRUSH BOX ASSEMBLY | 26 FILTER |
| 3 VAPOUR ASSISTER | 15 COVER (UPPER BEARING) | 27 PUMP BODY |
| 4 JOINTING RING | 16 UPPER BEARING | 28 GLAND |
| 5 LOCATING DOWEL | 17 BRUSH | 29 BREEZE PLUG |
| 6 MOTOR CASING | 18 RETAINING PLATE (LOWER BEARING) | 30 DRAIN PLUG |
| 7 SEALING RING | 19 SCREW (END PLATE) | 31 SEALING WASHER |
| 8 SEAL COMPRESSION RING | 20 SCREW (RETAINING PLATE) | 32 BREATHER PLUG |
| 9 BEZEL RING | 21 SHAKEPROOF WASHER | 33 DIFFUSER JOINT RING |
| 10 YOKE | 22 END PLATE | 34 DIFFUSER |
| 11 MOTOR BODY | 23 LOWER BEARING | 35 BY-PASS VALVE |
| 12 FIELD COIL | 24 DUST SHIELD | 36 CIRCLIP |

Fig. 1. Sectional view of BP type pump

impeller spindle. A mounting is provided on the upper side of the pump body to seat the driving motor. Ducts are also bored in the casting for motor ventilation, fuel inlet and outlet, and gland drains.

Pump base

9. The pump base houses the impeller assembly; the impeller chamber in which the impeller rotates is shaped in the design of the casting.

Fuel sealing gland

10. The metal bellows fuel sealing gland comprises a brass backplate, to which is sweated a brass bellows, with a bronze seal ring to the other end. The seal ring is guided by four splines cut round its outer circumference and engaging with four lugs projecting from the backplate. These parts form a gland unit which is pressed into the pump casing. The bronze seal ring, which is stationary, rubs against a rotating carbon ring

RESTRICTED

shrunk permanently into the back of the impeller, thus preventing fuel seeping through to the motor lower bearing.

Electrical connection

11. The electrical input is via a mated Breeze-type plug and socket. The plug, usually an integral part of the pump, is fitted to a machined boss located on the pump body. With the immersed type of pump, the plug is fitted to that part of the pump body which is accessible from the outside of the fuel tank for mating with the socket which carries the incoming electrical supply input to the driving motor.

OPERATION

12. Fuel from the tank enters the pump through the filter and inlet, where the impeller, rotated by the driving motor, draws fuel via the fuel duct to the delivery outlet, and thence to the fuel inlet side of the aircraft engine-driven pump.

INSTALLATION

13. There are different methods for removing or installing the different types of pumps in the same group. Instructions for removal and installation of a particular type of pump in the same group will be found in A.P.4343D, Vol. 1, Book 2, Sect. 7, 8, and 10, or in the relevant Aircraft Handbook.

14. The general instructions for removing a pump is to shut off the fuel supply from the tank, disconnect all the pipes and the electrical cable and socket from the pump. The removal of the nuts, screws, etc., from the pump mounting releases the complete pump from its installation.

15. When installing a new or reconditioned pump it is important that all transit caps and plugs are removed and all apertures inspected before installation. When the pump has been installed all connections and union nuts must be wire-locked. Ensure that the gland drain is piped to atmosphere and that the end of the drain piping faces towards the rear of the aircraft, to prevent possible pressurizing of the gland drain during flight.

16. Care must be exercised during removal or installation of a pump from the aircraft that no damage is caused to the impeller.

SERVICING

17. Examine all pipe connections for leaks and fit new joint washers as necessary. The leakage from the gland drain should be noted when the pump is in operation; if the leakage is excessive, replace with a new or reconditioned pump.

18. Check the electrical connection and ensure that all nuts and screws are tight and the locking wires intact.

19. In the event of excessive current consumption, low delivery pressure, due to abnormal friction caused possibly by a damaged impeller or a faulty fuel sealing gland, the pump must be replaced by a new or reconditioned one.

20. For further information on the General Repair and Reconditioning instructions for the BP group of pumps attention is drawn to A.P.4343, Vol. 6, Sect. 16, App. 2. For information on any individual type of pump of this particular group, attention is drawn to A.P.4343D, Vol. 1, Book 2, and Vol. 6, Sect. 7, 8, and 10.

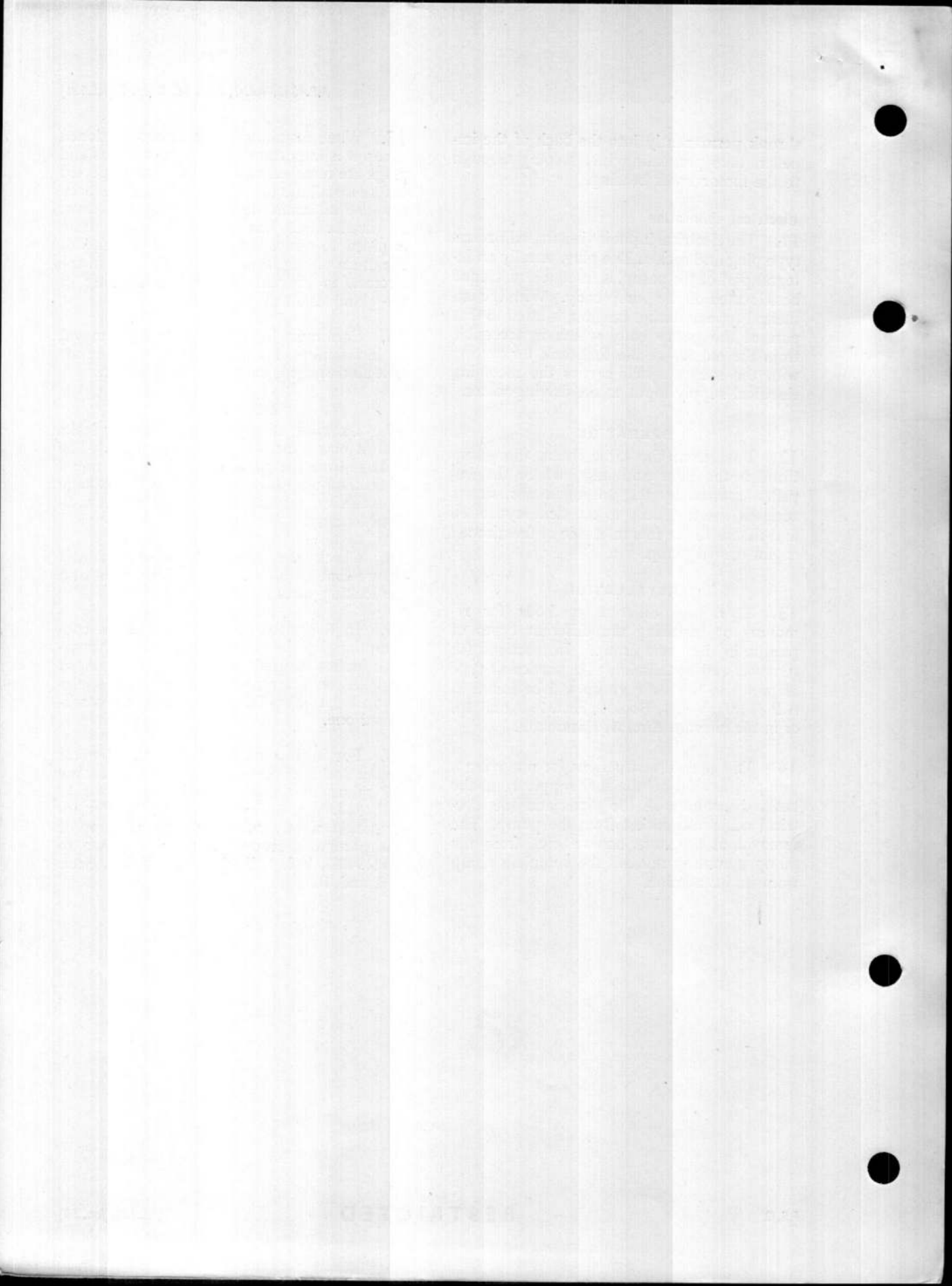

This file was downloaded
from the RTFM Library.

Link: www.scottbouch.com/rtfm

Please see site for usage terms,
and more aircraft documents.

