

## Chapter 5

# WIDE SPEED RANGE GENERATING SYSTEMS

### LIST OF CONTENTS

	Para.		Para.
Introduction ... ..	1	Effects of load shedding ... ..	35
Description ... ..	4	Operation under fault conditions ... ..	39
Control unit ... ..	5	Major earth-fault on generator main cable ... ..	41
Voltage regulating circuit ... ..	6	Minor earth-fault on generator main cable ... ..	42
Equalizing circuit ... ..	8	Generator develops excess voltage ... ..	45
Field tickling circuit ... ..	13	Generator open-circuit indication ... ..	49
Voltage raising circuit ... ..	17	Installation ... ..	50
Operation ... ..	20	Servicing ... ..	52
Normal operation		Fault location ... ..	57
Starting up ... ..	24	Generator fails to close on to bus-bar ... ..	59
Shutting down ... ..	30	Faulty voltage regulation ... ..	61
Test/flight change-over switch ... ..	32	Incorrect load sharing ... ..	62

### LIST OF TABLES

	Table
Sequence of operation of control and protective devices ... ..	1

### LIST OF ILLUSTRATIONS

	Fig.		Fig.
Block diagram of typical system ... ..	1	Over-voltage relay circuit ... ..	6
Voltage regulating circuit ... ..	2	Differential-voltage relay unit ... ..	7
Equalizing principle ... ..	3	Major earth-fault ... ..	8
Equalizing circuit ... ..	4	Minor earth-fault ... ..	9
Field tickling circuit ... ..	5	Over-voltage selector relay circuit ... ..	10

### LIST OF APPENDICES

	App.
Type 507 generator system ... ..	1
Type 512 generator system ... ..	(to be issued later)
Type 517 generator system ... ..	(to be issued later)

RESTRICTED

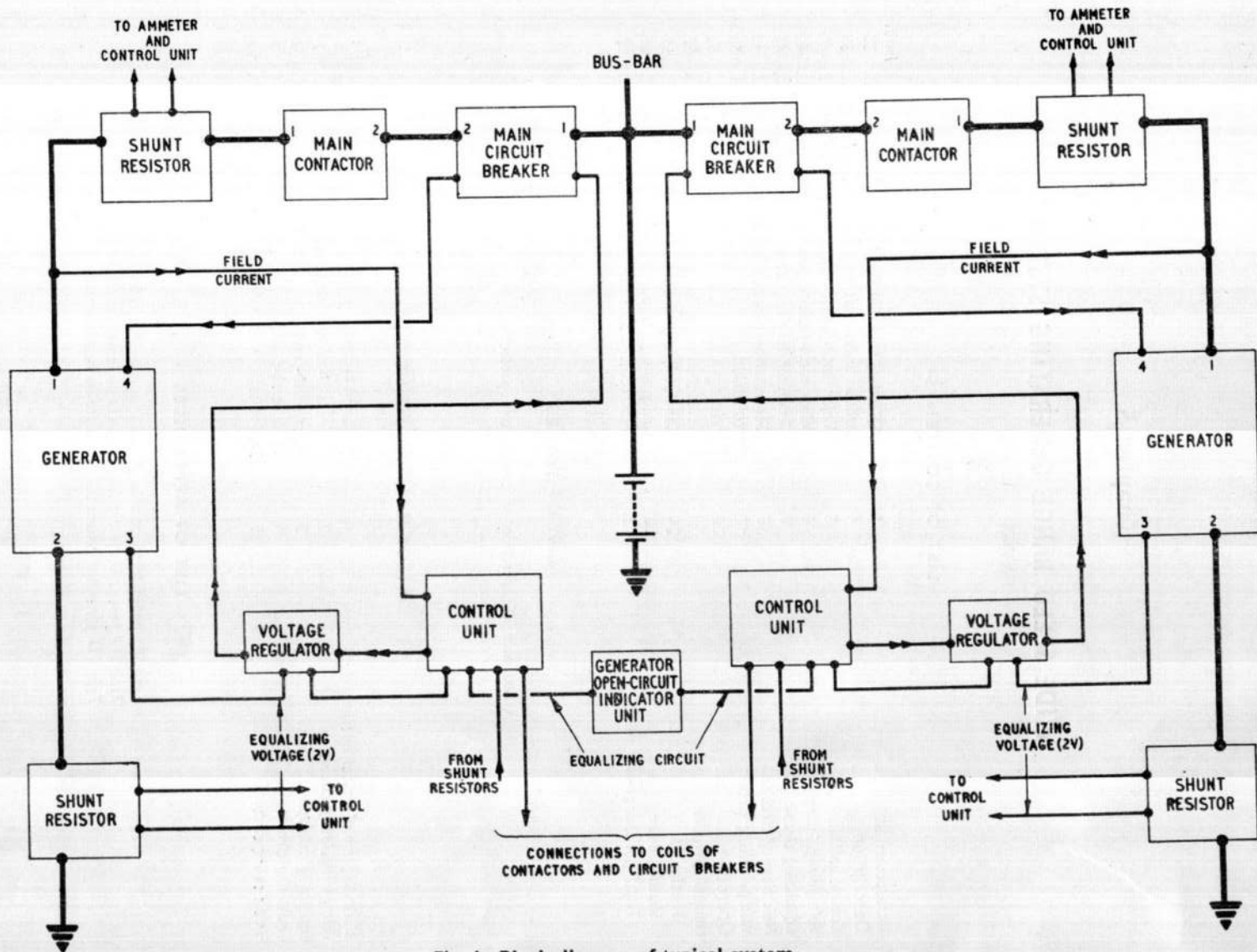

Fig. 1. Block diagram of typical system

### Introduction

1. The wide speed range generator systems, designed for use with the various engine-driven wide speed range generators, are generally similar to the basic system described in this chapter. The details of the particular systems, modified to suit the generators installed and the requirements of the aircraft, are covered by the appendices.

2. For duplication and flexibility of supply, a typical aircraft installation will usually require two or more generators feeding a common bus-bar. In multi-engine aircraft, each generator may be directly driven by the engine to which it is coupled, or if a suitable intermediate gearbox is installed, any one engine may drive two or more generators.

3. A direct-current system is used, operating at a nominal voltage of 24 volts, the bus-bar being initially maintained at this level by the aircraft batteries. With the system in operation, the voltage level is raised to 28 volts, and the system is designed to maintain this condition over wide ranges of engine speed and generator load.

### DESCRIPTION

4. A simple block diagram of a typical installation having two generators and using single-pole wiring with the negative pole earthed to the airframe is shown in fig. 1. Additional generators, together with their associated control equipment, can be installed and connected in parallel to the bus-bar should the power requirements of the aircraft so demand.

### Control unit

5. In addition to the shunt resistors, contactor, circuit-breaker and voltage regulator, each generator has an associated control unit which is of a standard design for all the wide speed range systems. Operation in conjunction with the variously rated generators is achieved by the use of appropriate shunt resistors. The control unit, which is fully described in A.P.4343B, Vol. 1, Sect. 7, Chap. 20, has 18 terminals, and, in addition

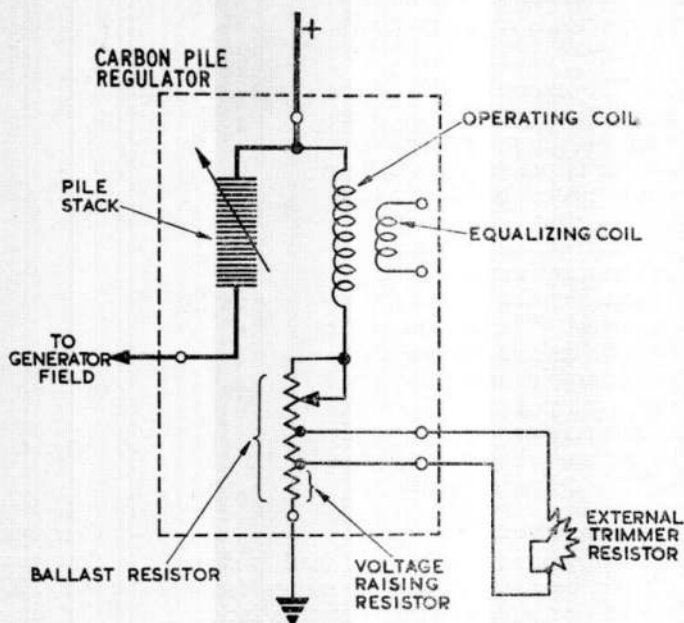

Fig. 2. Voltage regulating circuit

to various resistors, rectifiers and a capacitor, contains the following relays:—

- (1) Polarized relays:
  - (a) Differential-voltage relay
  - (b) Differential-current relay
  - (c) Over-voltage relay
  - (d) Over-voltage selector relay
- (2) Non-polarized relays:
  - (a) Field-tickler relay
  - (b) Equalizer isolating relay

### Note . . .

The terminal numbers in the illustrations in this chapter refer to those of the control unit.

### Voltage regulating circuit

6. To maintain the generated voltage within the specified limits of 28 volts  $\pm 2.5$  per cent at any load up to the rated maximum and at any speed between the rated minimum and maximum, a carbon-pile voltage regulator is used to control the shunt field current, a typical circuit being shown in fig. 2. The terminal voltage of the generator is applied through a field circuit-breaker and the control unit (fig. 1) to the operating coil of the voltage regulator, the carbon pile of which is in series with the shunt field winding of the generator. Any variation of the generator terminal voltage thus alters the pile resistance

and hence the field current, the changes being in such a direction as to restore the terminal voltage to its correct value.

7. The operating coil of the voltage regulator is in series with a ballast resistor. This resistor is pre-set when setting the regulator, but final adjustment after installation is effected by means of the external trimmer resistor, which is mounted on the engineer's control panel. The portion of the ballast resistor between the lowest tapping and the earthed end is referred to as the voltage raising resistor, and is normally short-circuited when the generator is delivering power.

#### Equalizing circuit

8. To ensure that the total load is shared equally between all the generators feeding the bus-bar, an equalizing circuit is included in the system. The principle is illustrated in fig. 3, which shows a twin generator arrangement. The coils C, C represent the equalizing windings of the voltage regulators associated with generators No. 1 and No. 2, and the identical resistances R, R represent the resistances of the negative lines of the generators between the earth connections and the negative brushes. The equalizing connection is made, via the common point, between the negative brushes of the two generators.

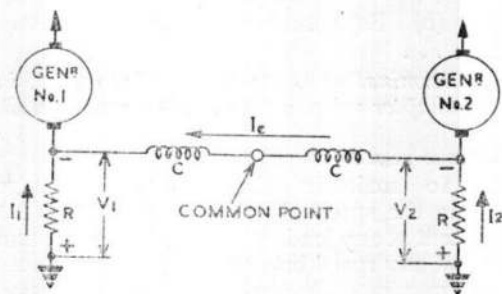

Fig. 3. Equalizing principle

9. Suppose that at a particular instant the load current  $I_1$  of generator No. 1 is greater than that of No. 2. Then the volt drop  $V_1$  will be greater than  $V_2$ , with the result that the negative brush of generator No. 1 will be at a lower potential than that of No. 2.

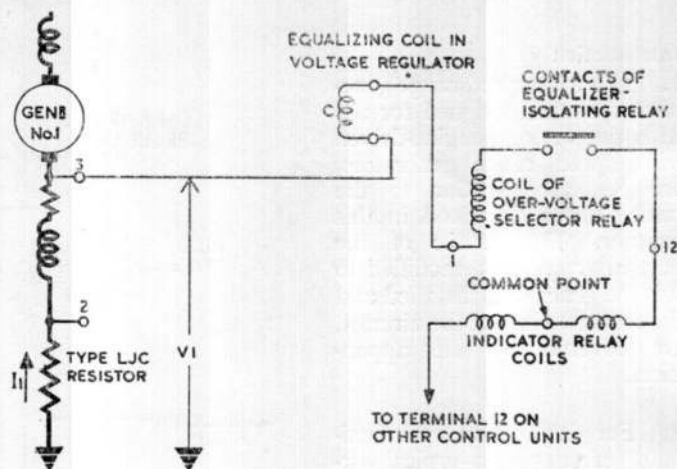

Fig. 4. Equalizing circuit

Consequently, an equalizing current  $I_e$  will flow towards generator No. 1 as indicated in fig. 3. The coils C, C are connected such that the effect of this current is to raise the terminal voltage of generator No. 2 and lower that of No. 1, thus effectively reducing the difference in load current between the two generators.

10. Typical connections for the equalizing circuit are shown in fig. 4. The voltage  $V_1$  is developed mainly across the series field of the generator between terminals No. 2 and No. 3. In some types of generator, an additional resistance may be included in series with the windings as illustrated. A small proportion (approximately one-eighth) of the voltage  $V_1$  is developed externally across the shunt resistor connected between generator terminal No. 2 and earth. In fig. 4 the equalizing connection is completed from generator terminal No. 3 through the equalizing winding of the voltage regulator to terminal No. 1 on the control unit, and thence via the contacts of the equalizer-isolating relay (para. 29) to terminal No. 12. The connection is completed through the indicator relay coil (para. 49) to the common point where the connections from the other generators in the system also terminate.

11. At full load, the total equalizing voltage  $V_1$  is approximately 2 volts. The resistance of the equalizing connection is comparatively low, and a slight difference between the equalizing voltages of a pair of generators causes an effective current to flow. It is essential, therefore, that the

specified maximum lead resistances for the equalizing connections are not exceeded when installing the system.

12. For the equalizing circuit to be effective the open-circuit terminal voltages of each generator must be adjusted by means of their voltage regulators to the common value of 28 volts. With this initial setting, the load on each generator will not differ by more than 10 per cent of its rated full-load current from the average generator load.

#### Field tickling circuit

13. When run up to speed a shunt generator is normally dependent upon its residual magnetism or remanent flux density for the building up of its terminal voltage. Under certain conditions this residual magnetism may have become reduced or even reversed in direction, and in such cases the generator may either not excite or else build up with reversed polarity.

14. To ensure that a generator in the wide speed range system always excites with the correct polarity, a field tickling arrangement is used to excite the shunt field from a separate source during starting. The circuit (fig. 5) shows the arrangement in its normal running condition with the field-tickler relay

de-energized and the generator field connected in shunt.

15. On depressing the starter push-switch, the field-tickler relay is energized and its normally open contacts close to complete the tickling circuit and so energize the generator field from the battery via the bus-bar. When the push-switch auxiliary contacts open, the field-tickler relay is de-energized, thus breaking the tickling circuit. The field is now self-excited via the normally closed contacts of the relay, the 10-ohm resistor serving to maintain continuity during the interval of relay operation.

#### Note . . .

*Should the starter push-switch remain depressed, the rising terminal voltage of the generator bucks the bus-bar voltage, the relay dropping off when the voltage difference falls to about 5 volts.*

16. In twin-engine installations incorporating a gearbox whereby either engine drives both generators, depression of either starter push-switch operates both field-tickler relays. This is achieved by the connections to terminals No. 7 on each control unit, the blocking rectifiers 1 and 2 preventing any interaction between the two circuits.

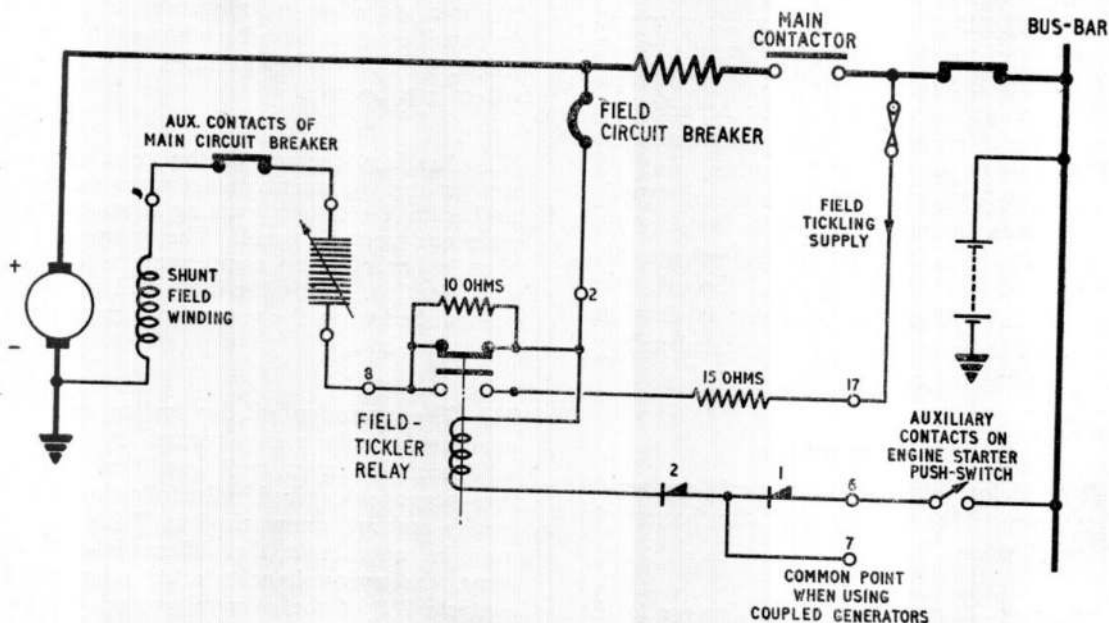

Fig. 5. Field tickling circuit

RESTRICTED

### Voltage raising circuit

17. A voltage raising circuit, incorporating a differential-voltage relay, is included in the system to ensure that a generator is not connected to the bus-bar until its terminal voltage exceeds the bus-bar voltage. The differential-voltage relay will not operate until the differential between the two voltages has increased to 0.5-0.75 volts.

18. When the first generator is run up, the bus-bar is at the battery level of approximately 24 volts, and since the generator is regulated to 28 volts, a sufficient differential voltage is obtained. As soon as one generator has closed on to the bus-bar, the level of the latter rises to 28 volts, and consequently the other generators must develop a voltage in excess of 28 volts to operate the differential voltage relay.

19. Prior to closing on to the bus-bar, the generator terminal voltage is temporarily increased to about 30 volts by means of the voltage raising resistor in the voltage regulator (fig. 2). Being in series with the operating coil of the regulator, the current through the latter is such that the generator is regulated to approximately 30 volts. An adequate differential voltage is thus obtained, the differential-voltage relay operates, and the generator closes on to the bus-bar. When the main contactor closes, a pair of its auxiliary contacts short out the voltage raising resistor. The current through the operating coil of the regulator is thus increased so as to reduce the regulated voltage of the generator to the 28-volt level.

### OPERATION

20. Before starting the aircraft engines it is essential to ensure that the battery is switched on.

**Warning**—If this is not done, damage to the system may result.

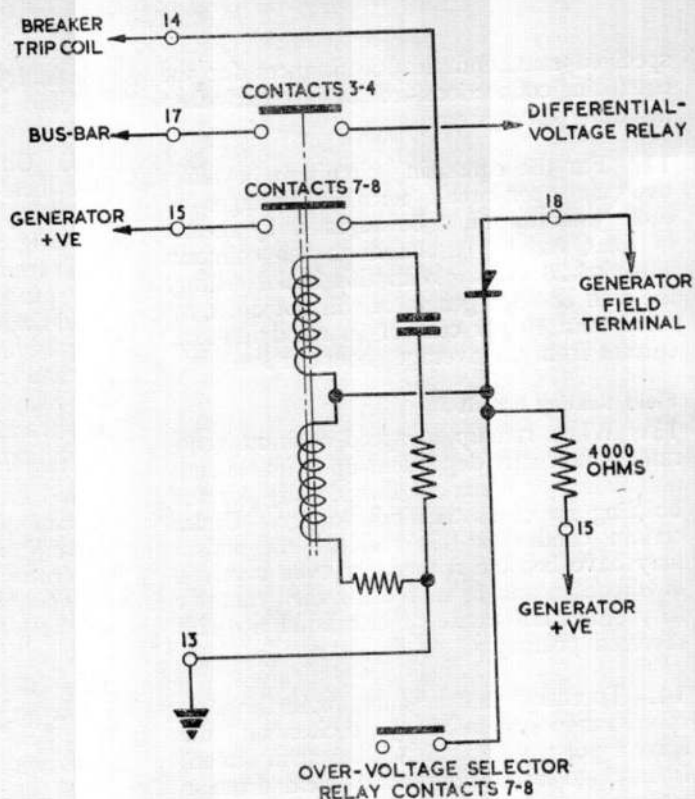

Fig. 6. Over-voltage relay circuit

21. Normally, the main and field circuit-breakers will be in the closed position, and the main contactor in its open position. If the circuit-breakers have been tripped for any reason, they must be re-closed before the system can operate.

22. Auxiliary contacts on the main circuit-breaker and the main contactor connect the bus-bar to a common warning lamp on the engineer's control panel. The lamp is lit when either of these components is in the open position. Thus the lamp will only be extinguished when the generator is connected to the bus-bar.

23. The operation of the system can be considered firstly under normal conditions, and secondly under fault conditions. The sequences are described in the following paragraphs and are summarized in Table 1. It may be noted that the differential-current relay, the over-voltage selector relay, and contacts 7-8 of the over-voltage relay only operate under fault conditions.

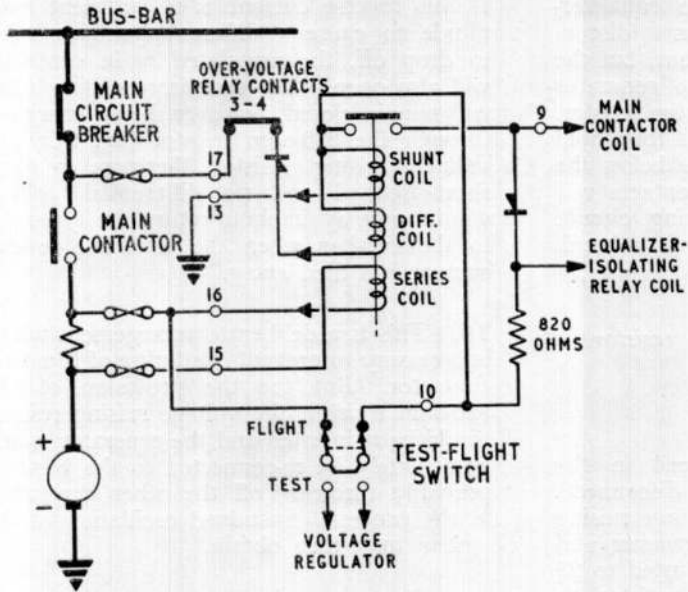

Fig. 7. Differential-voltage relay unit

**Normal operation***Starting up*

24. When the engine starter push-switch is depressed, the field-tickler relay operates as described in para. 13. The operating coil of the over-voltage relay (fig. 6) is connected via terminal No. 18 of the control unit to the field terminal of the generator, and when the generator terminal voltage has built up to approximately 16 volts, contacts 3-4 of the relay close.

**Note . . .**

*Since the relay is polarized, it will only operate if the generator has built up with the correct polarity.*

25. The closing of contacts 3-4 of the over-voltage relay completes the coil circuits of the differential-voltage relay, which will tend to close when its coil currents flow in the directions shown (fig. 7). The shunt coil is energized by the generator terminal voltage, but unless this voltage rises considerably in excess of normal, the relay will not operate. No current can flow in the series coil until the main contactor is closed and load current flows through the shunt resistor, and, because of the blocking rectifier, no reverse current from the bus-bar can flow through the differential coil.

26. When the generator terminal voltage exceeds the bus-bar voltage, however, current will flow through the differential coil in the operating direction, and when the differential reaches 0.5 to 0.75 volts the relay will operate and its contacts will close to connect the generator terminal voltage to the coil of the main contactor. The contactor will then close and connect the generator to the bus-bar.

27. When the contactor closes, one pair of auxiliary contacts will short-circuit the voltage raising resistor in the voltage regulator (para. 7), another pair will connect a supply from the generator output to the relays controlling the inverters associated with the

generator, and a third pair will open to cut off the supply to the warning lamp on the control panel.

28. The closing of the contactor shorts out the differential coil of the relay, but it will remain closed since sufficient hold-in current still flows in the shunt coil.

29. In addition to energizing the contactor coil, the contacts of the differential-voltage relay connect a supply through a blocking rectifier to the coil of the equalizer-isolating relay. This relay operates to close the equalizing circuit (para. 8), and also connects a further short-circuit across the voltage raising resistor.

*Shutting down*

30. The voltage regulator varies the generator field current so as to maintain a constant terminal voltage over a certain speed range. When the engine is shut down and the generator speed falls below the limit of this range, the terminal voltage will drop and reverse current will be drawn from the bus-bar. This causes the current in the series coil of the differential-voltage relay to be reversed, and when the reverse current flowing through the shunt resistor reaches a value of between 20 and 25 amp. the current through the series coil is sufficient to open the relay.

**31.** The opening of the contacts of the relay disconnects the supplies to the coils of the main contactor and the equalizer-isolating relay. The former opens to disconnect the generator from the bus-bar, but the latter remains energized by the generator terminal voltage through the 820-ohm resistor. The equalizer-isolating relay will thus hold in until the terminal voltage falls below the drop-off value, whereupon its contacts will open to disconnect the equalizing circuit. The over-voltage relay also opens to break the connection to the bus-bar.

**Note . . .**

*The purpose of the 820-ohm resistor is explained in para. 35.*

*Test flight/change-over switch*

**32.** When this switch is placed in the "test" position, the generator disconnects itself from the bus-bar. The voltage raising resistor remains short-circuited, however, and the terminal voltage may be adjusted to 28 volts by means of the trimmer resistor on the engineer's control panel. The generator may also be started with the switch in the "test" position, but it will not close on to the bus-bar.

**33.** When the switch is opened, the supply to the shunt coil of the differential-voltage relay (fig. 7) is interrupted, and the relay is sufficiently de-energized for it to open. The main contactor then opens to disconnect the generator from the bus-bar. The equalizer-isolating relay also opens, and in doing so will remove the short on the voltage raising resistor. However, the placing of the switch in the "test" position re-imposes a short-circuit on this resistor and the generator remains at the 28-volt level.

**34.** If the generator is started with the switch in the "test" position, the system will operate in its normal sequence except that the excess terminal voltage will not be available to operate the differential-voltage relay. The generator will not therefore close on to the bus-bar until the switch is moved over to the "flight" position, thus removing the short on the voltage raising resistor and re-connecting the shunt coil of the differential-voltage relay.

*Effects of load shedding*

**35.** If a heavy load is suddenly switched off the bus-bar, it is probable that one or more generators will draw a transient reverse

current since the response times of their respective voltage regulators are not identical. If this reverse current is of sufficient magnitude to cause a differential-voltage relay to drop off, the associated main contactor will also open. The equalizer-isolating relay will remain closed, however, being energized through the 820-ohm resistor (fig. 7). The voltage raising resistor therefore remains short-circuited and no differential voltage will become available to return the generator to the bus-bar when the transient reverse current has died away.

**36.** This is a deliberate arrangement which is necessary to prevent chattering of the main contactor. But for the provision of the 820-ohm resistor, the voltage raising resistor would be re-inserted and the generator would immediately be re-connected to the bus-bar, probably throwing off the other generators in the process. Sustained oscillation of the system may then obtain.

**37.** At least one generator will remain on the bus-bar since a differential voltage is automatically obtained if the bus-bar falls to the battery voltage level. As the equalizing circuit remains connected, it performs its normal function when load is again drawn from the system. Its action is to depress the voltage of the generator or generators already on the bus-bar and so create a differential voltage which will bring the remaining generators on as well.

**38.** At the upper end of the speed range the field current necessary to maintain the generator terminal voltage at the 28-volt level is greatly reduced. Load shedding at these speeds may therefore cause the voltage across the field to fall to a very low value, and since the over-voltage relay is energized from the field terminal, it may drop off. To prevent this occurrence, a separate supply to the relay coil is taken from the positive output of the generator through a 4,000-ohm resistor.

**Note . . .**

*This additional coil supply is not incorporated in earlier versions of the control unit.*

**Operation under fault conditions**

**39.** In addition to fuses, and a thermal trip circuit-breaker to prevent field circuit overload, protective circuits are incorporated in the system to prevent damage due to earth faults and over-voltage. The protections are designed to isolate only the faulty parts of



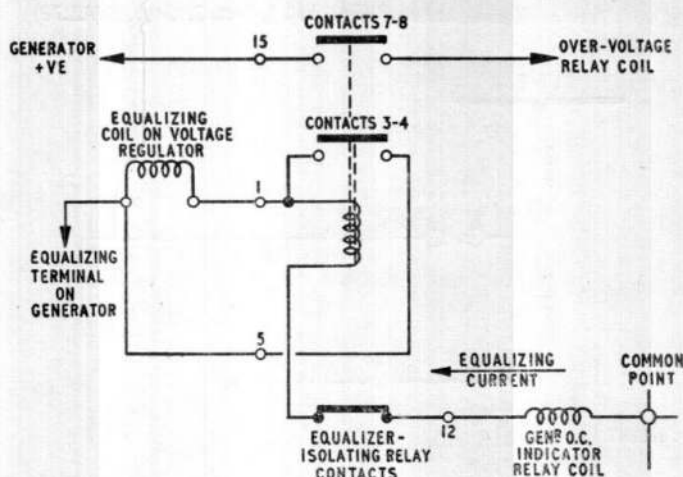

Fig. 10. Over-voltage selector relay circuit

43. Protection against this type of fault is afforded by the differential-current relay. This relay is fitted with two opposing coils connected respectively to the positive and negative line shunt resistors (fig. 9). Under normal conditions the same current flows through both shunt resistors and the net ampère-turns produced by the coils is zero.

44. If a minor earth fault occurs between the shunt resistors, the current through the negative resistor exceeds that through the positive resistor and the balance of ampère-turns in the relay coils is upset. When the fault current reaches from 50 per cent to 75 per cent of full-load current, the relay closes and energizes the trip coil of the main circuit-breaker. The circuit-breaker then trips to disconnect the generator and to interrupt its field circuit.

#### Generator develops excess voltage

45. When a generator is running singly and its terminal voltage rises abnormally, contacts 7-8 of the over-voltage relay (fig. 6) close when the voltage at the field terminal exceeds 31 volts. The trip coil of the main circuit-breaker is energized and the generator then comes off the bus-bar and ceases to excite. The resistor and capacitor connected across the relay coils give a time delay to the relay and so prevent operation under transient voltage conditions.

46. With two or more generators connected to the bus-bar, the one generating excess voltage may completely override the equalizing system, resulting in reverse current being fed into the remaining generators and tripping

them off the bus-bar. The faulty generator would, however, remain connected to the bus-bar either running an overload or generating excess voltage if the system was lightly loaded.

47. The over-voltage selector relay (fig. 10) is used to identify the faulty generator and temporarily to accentuate the fault so as to obtain sufficient over-voltage to close the over-voltage relay and trip the main circuit-breaker.

48. The coil of the over-voltage selector relay is in series with the equalizing circuit and its contacts 3-4 are connected in shunt with the equalizing coil of the voltage regulator. The equalizing current will be flowing towards the faulty generator and away from the others, and, since the over-voltage selector relays are polarized, only that associated with the faulty generator will be energized in the closing direction. When the bus-bar voltage has risen to approximately 30 volts, the equalizing current will be of sufficient magnitude to close contacts 3-4 of the relay. The equalizing coil will then be shunted and its depressing effect on the terminal voltage removed. Consequently the fault develops further, with a resultant increase in equalizing current which closes contacts 7-8 of the relay. These contacts connect the terminal voltage of the generator, which will now be approximately 31 volts, to the coil of the over-voltage relay. A further rise in terminal voltage will operate this relay and thus trip the main circuit-breaker. The faulty generator is thus brought off the bus-bar and shut down.

#### Generator open-circuit indication

49. If an open-circuit fault occurs in a generator, there will be no volt drop between its negative terminal and the equalizing connection terminal. Hence a comparatively large equalizing current will flow towards the other generators. The operating coils of the relays in the indicator unit are inserted in the equalizing connection, and since the relays are polarized, only that associated with the faulty generator will operate. Its contacts close to connect a supply from the bus-bar to the warning lamp on the engineer's control panel. It should be noted that the normal value of equalizing current is insufficient to operate these indicator relays.

**INSTALLATION**

**50.** It is essential that the total resistance of the two leads from the positive line shunt resistor to terminals No. 15 and No. 16 on the control unit does not exceed 0.01 ohm. The resistance of the leads from the negative line shunt resistor to terminals No. 11 and No. 13 must also be of the same order.

**51.** The components of the systems should be installed as described in their respective chapters in the A.P.4343 series, and with reference to the relevant Aircraft Handbook.

**SERVICING**

**52.** The servicing of the components of the system is covered in the chapters on these components in the A.P.4343 series. Reference should also be made to the relevant Servicing Schedules.

**53.** Apart from checking that the components are securely mounted and that all connections are tight, no attention other than occasional trimming of the generator terminal voltages is required on the system as a whole.

**54.** With all generators running at a common speed, the voltage of each generator should be adjusted by the trimmer on the engineer's control panel with the test/flight change-over switch in the "test" position, and the value set to 28 volts as accurately as possible.

**55.** When each generator terminal voltage has been set, check as far as possible that the bus-bar voltage remains within the limits of 28 volts  $\pm 2.5$  per cent at any load up to the rated maximum and at any speed within the rated minimum and maximum. Under over-load conditions, the bus-bar voltage must remain within these limits up to 150 per cent of the rated maximum load and at any speed from the rated maximum down to 125 per cent of the rated minimum.

**56.** The equalizing circuit must also function satisfactorily. The load current delivered by any one generator must not differ by more than 10 per cent of its rated full-load current from the average load current per generator.

**Note . . .**

*No attempt should be made to improve the*

*load balance by trimming the terminal voltages of the generators while they are on load.*

**Fault location**

**57.** When the various protective circuits operate under fault conditions, the main circuit-breaker is tripped and the faulty generator isolated and shut down. Indication is given by the lighting of the warning lamp on the engineer's control panel. If the generator develops an open-circuit fault, the circuit-breaker is not tripped, but the open-circuit indicator relay lights the lamp.

**58.** Faults in the control circuits may cause incorrect operation without tripping the main circuit-breaker, and some of the more likely faults are discussed in the following paragraphs.

*Generator fails to close on to bus-bar*

**59.** In such an event the appropriate warning lamp will remain alight, indicating that the main contactor has not closed. After confirming that the main and field circuit-breakers are in fact closed, make a voltmeter check to ensure that the generator is exciting. If not, check the field circuit for continuity.

**60.** If the generator terminal voltage appears at terminal No. 1 of the main contactor, then either the contactor itself or the control unit is suspect. Reference should be made to the appropriate chapters in the A.P.4343 series before checking these items.

*Faulty voltage regulation*

**61.** This will most likely be due to a fault in the voltage regulator. A fluctuating or erratic voltage can be caused by wear on the carbon washers in the pile stack. If the voltage cannot be trimmed, but is regulated under load conditions, then the fault is probably in the trimmer or its connecting leads.

*Incorrect load sharing*

**62.** If the equalizing circuit is at fault, the generator with the highest terminal voltage will carry most of the load. In such a case, check the equalizing circuit for continuity and pay particular attention to the terminal connections. Also check that the equalizer-isolating relay closes satisfactorily.

TABLE 1

## Sequence of operation of control and protective devices

NORMAL CONDITIONS			FAULT CONDITIONS		
Starting up	Shutting down	Test/flight switch placed in "test" position during operation	Major earth fault on generator main cable	Minor earth fault on generator main cable	Excess terminal voltage develops
Battery switch closed and main and field circuit-breakers closed manually	Engine shut down	Differential-voltage relay opens	Main circuit-breaker trips due to reverse current	Differential-current relay closes	Contacts 3-4 of over-voltage selector relay close
Starter push-switch depressed. Field-tickler relay operates momentarily	Differential-voltage relay opens	Main contactor and equalizer-isolating relay open	Main contactor opens. System de-energized	Main circuit-breaker trips	Contacts 7-8 of over-voltage selector relay close
Contacts 3-4 of over-voltage relay close	Main contactor opens			Main contactor opens. System de-energized	Contacts 7-8 of over-voltage relay close
Differential-voltage relay closes	Equalizer-isolating relay opens				Main circuit-breaker trips
Main contactor and equalizer-isolating relay close	Over-voltage relay opens. System de-energized				Main contactor opens. System de-energized

RESTRICTED

## Appendix 1

## TYPE 507 GENERATOR SYSTEM

## LIST OF CONTENTS

Introduction ... ..	Para.
Description ... ..	1
	2

## LIST OF ILLUSTRATIONS

Type 507 generator system ... ..	Fig.
	1

**Introduction**

1. The wide speed range generating system used with the Type 507 generator embodies all the features described in the chapter. Its circuit diagram (*fig. 1*) will be generally applicable, although minor changes may be made to suit a particular aircraft installation.

**DESCRIPTION**

2. The major components of the system are given in the following table, together with the references to the publication in the A.P.4343 series in which details of these items may be found.

3. The trimmer resistor is a variable wire-wound resistor of 5 ohms maximum resistance. It is connected to the voltage regulator and is used to trim the open-circuit terminal voltage of the generator. It is remotely mounted on the engineer's control panel together with the double-pole test/flight change-over switch and the warning lamp.

4. The shunt resistors in the positive and negative lines provide a drop of 250 mV each when carrying 200 amp.

**Major components of system**

Component			Reference			
Item	Type	Stores Ref.	A.P.	Vol.	Sect.	Chap.
Generator	507	5UA/6004	4343A	1	3	14
Voltage regulator	94	5UC/5937	4343B	1	1	31
Control unit	1B	5CW/4646	4343B	1	7	20
Main contactor	B.T.H. Type LDA 200-B4	5CZ/4813	4343C	1	3	37
Main circuit-breaker	1B No. 2	5CY/4625	4343B	1	10	10
Field circuit-breaker	A3	5CY/2561	4343B	1	10	6
Trimmer resistor	3	5UC/5209	—	—	—	—
Line shunt resistor	B.T.H. Type LJC 200-E2	5UC/5996	—	—	—	—
Test/flight switch	—	5CW/4226	—	—	—	—

**RESTRICTED**

(A.L.78, Apr. 55)

RESTRICTED

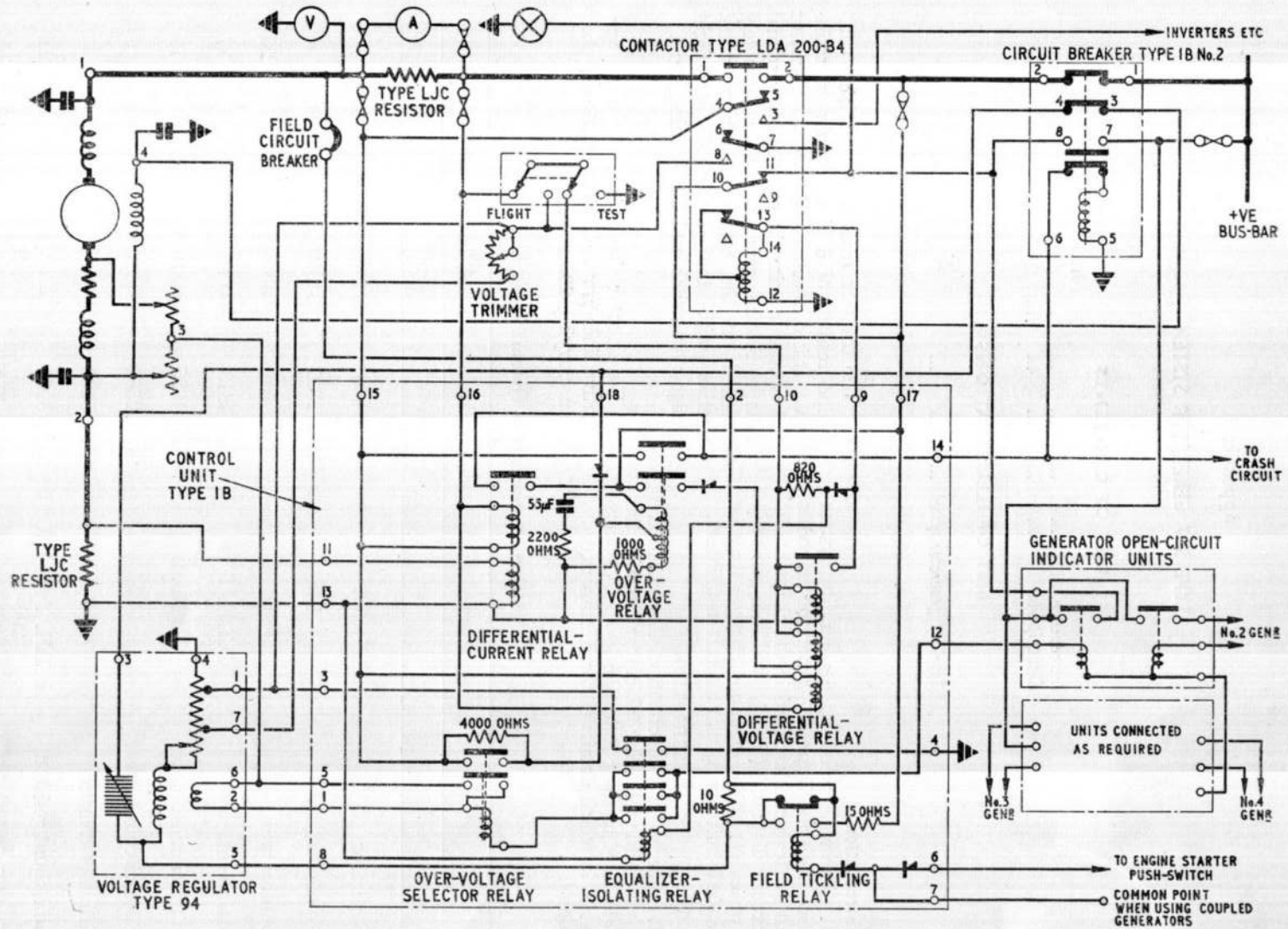

Fig. 1. Type 507 generator system

This file was downloaded  
from the RTFM Library.

Link: [www.scottbouch.com/rtfm](http://www.scottbouch.com/rtfm)

Please see site for usage terms,  
and more aircraft documents.



LIGHTNING MK. 1  
COVER PITOT HEAD  
EB2-88-5111