

Obsolete

Chapter 17

GENERATOR, TYPE 163 (E.E. Type AE 2034)

LIST OF CONTENTS

	<i>Para.</i>		<i>Para.</i>
<i>Introduction</i>	1	<i>Governor assembly</i>	15
Description		<i>Tail end cover assembly</i>	16
<i>General</i>	2	<i>Drive-end cover assembly</i>	17
<i>Frame</i>	3	<i>Cooling</i>	18
<i>A.C. stator assembly</i>	4	<i>Capacitors</i>	19
<i>Shaft assembly</i>	5	Servicing	
<i>Driving end endplate</i>	6	<i>General</i>	20
<i>Driving end bearing</i>	7	<i>Carbon brushes</i>	21
<i>A.C. rotor</i>	8	<i>Commutator and sliprings</i>	22
<i>D.C. exciter armature</i>	9	<i>Lubrication</i>	23
<i>Exciter field assembly</i>	10	<i>Underspeed governor</i>	24
<i>Sliprings</i>	11	Testing	
<i>Slipring brushgear</i>	12	<i>No load test</i>	25
<i>D.C. exciter brushgear</i>	13	<i>Governor micro switch setting</i>	26
<i>Tail end bearing</i>	14	<i>Insulation tests</i>	27

LIST OF ILLUSTRATIONS

	<i>Fig.</i>
<i>Generator, Type 163</i>	1
<i>Generator, Type 163 sectioned assembly</i>	2
<i>Internal circuit diagram</i>	3
<i>Test circuit diagram</i>	4

RESTRICTED

LEADING PARTICULARS

Generator, Type 163	Ref. No. 5UA/6646
Rating	9 kVA, 3 phase, 400 c/s
Rated voltage	200 volts a.c.
Rated current	26 A
Voltage regulator	Type 116 (Ref. No. 5UC/6463)
Control unit	Type AE 7000 Mk. 2 (Ref. No. 5UC/6461)
Regulated voltage	200 volts a.c. ($\pm 4\%$)
Nominal speed	8000 r.p.m.
Power factor	0.8 (lagging)
Operating altitude	0—10000 feet
Exciter field voltage	5 volts
Exciter field current	10.6A
Rotation from drive end	counter-clockwise
Brush grades:—						
Commutator	E.G.11
Sliprings	CM6
Brush spring tension:—						
Commutator	3½—5 oz.
Sliprings	7—10 oz.
Minimum brush lengths:—						
Commutator	$\frac{5}{16}$ in. on shortest side
Slipring	$\frac{5}{16}$ in.
Minimum commutator diameter	1.95 in.
Minimum slipring diameter	1.844 in.
Maximum depth of mica undercut	0.010 in.
Total weight	34 lb.
Overall length	16.5 in.
Overall height	11 in.
Overall width	8.3 in.

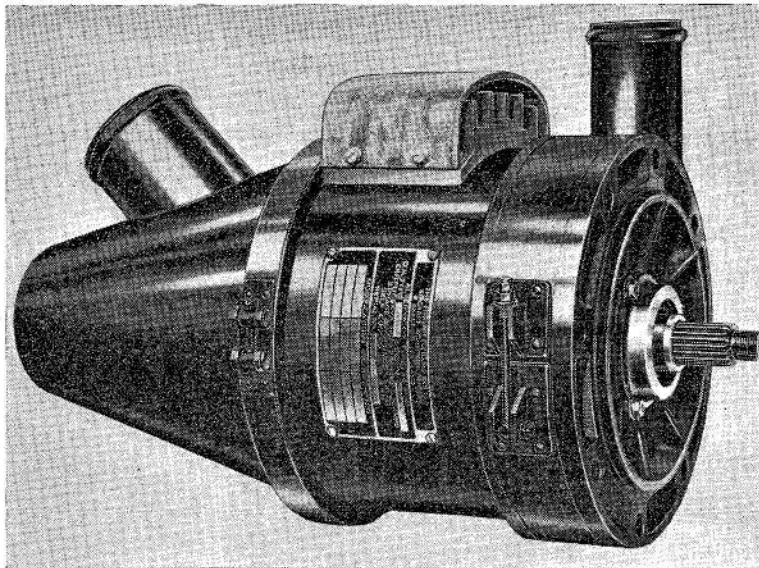

Fig. 1. Generator, Type 163

RESTRICTED

Introduction

1. The type 163, 9 kVA generator (*fig. 1*) is driven by an engine through a gearbox and when used in conjunction with a voltage regulator and control panel will provide a three phase 400 c/s a.c. supply, at a constant voltage.

DESCRIPTION

General

2. The generator has a salient construction 6-pole rotor and an integral exciter incorporated on the rotor shaft, which is supported in roller and ball bearings at the driving end and tail end respectively. Housed at the tail end of the shaft is a centrifugally operated governor device. This operates a micro switch to make and break the under-speed relay circuit in the Control Unit Type AE 7000 Mk. 2, this in turn closes and opens the contacts of the main supply contactor, ensuring that the generator only supplies its loads when the correct speed is reached and maintained. The machine incorporates a flange and spigot type mounting. A sectioned drawing is given in *fig. 2*.

Frame

3. The frame is a magnesium-alloy machined casting, housing the a.c. rotor, d.c. exciter armature, commutator and slip-rings. It carries the a.c. stator windings, terminal block, exciter field assembly, d.c. and slipring brushgear assembly, tail end bearing clamp and outer race of the ball bearing which supports the tail end of the rotor shaft. Attached to the extreme tail end of the frame is the governor housing, this houses the governor assembly.

A.C. stator assembly

4. The stator is laminated, has 45 slots on its inner diameter and is made up with the conductor slots skewed one slot pitch. The winding comprises 45 coils, 2 coils per slot, $2\frac{1}{2}$ slots per pole per phase. The ends of the coils are brought out to the terminal block which is mounted externally on the frame. The stator assembly is pressed into its position within the frame and secured by

two grub screws which are locked by peening.

Shaft assembly

5. The shaft assembly is hollow and comprises two halves, the driving end and tail end. The tail end locates into the driving end, and both are brazed together. Machined on the driving end are the splines which provide the means of drive for the generator.

Driving end endplate

6. The d.e. endplate is a magnesium-alloy machined-casting and it is secured to the frame by eight studs. These are located in the frame and pass through eight holes drilled in the endplate. Secured between the d.e. endplate and the frame and located in position by the same studs is a baffle plate. This assists in directing the flow of air drawn through the fan blade used for cooling the generator. The securing studs pass through the baffle plate and endplate locating with 2 B.A. nuts which are locked by double spring washers. The endplate has a steel bearing bush in which the outer race of the driving end roller bearing is a push fit.

Driving end bearing

7. The outer race of the roller bearing is held in position by the bush and the d.e. end cap; the end cap is secured to the d.e. endplate by three 2 B.A. bolts locating in the endplate and locked by tab washers. The inner race of the bearing is a push fit on the drive end of the rotor shaft, and is secured by a collar, which is also a push fit on the shaft. The d.e. endplate and the d.e. end cap are both recessed.

A.C. rotor

8. At the driving end of the shaft adjacent to the cooling fan is the rotating field rotor. This is keyed to the shaft. It is of six pole salient construction and the coils are wound on each pole to give poles of alternate polarity. Balancing of the rotor is accomplished in two ways; by means of balance weights, attached as required to the

RESTRICTED

coil support brackets on the d.c. side of the rotor assembly, at the end of the rotor poles and by adding brazing metal to the banding wire between the rotor and the d.c. exciter armature.

D.C. exciter armature

9. Mounted adjacent to the a.c. rotor and keyed to the shaft is the exciter armature assembly. This is retrogressive wave wound with 17 coils, the terminations of which are taken to the commutator at the t.e. of the armature assembly.

Exciter field assembly

10. The exciter field assembly comprises four main field poles of 49 laminations each, on which is wound the main shunt winding. Between each main field pole is an auxiliary pole (interpole) and on these is wound the auxiliary winding. The main field poles and auxiliary poles are secured within an iron yoke and the whole field assembly is fitted into the frame. After setting the neutral position it is locked in place by four set screws, these are locked by coating the threads with anti-track enamel.

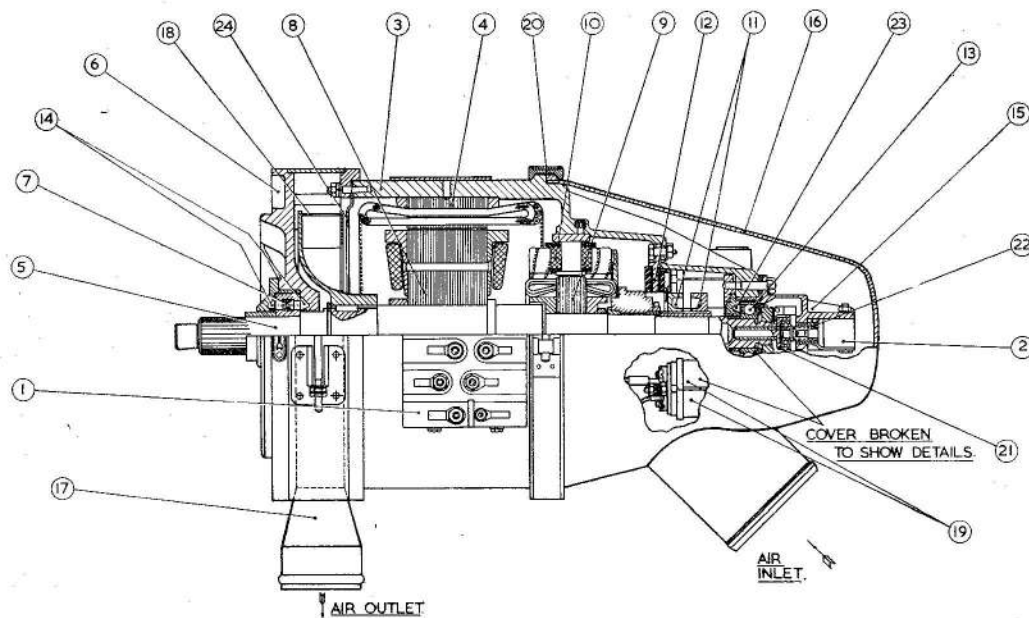

- | | |
|------------------------------|--|
| 1. TERMINAL BLOCK | 13. BALL BEARING |
| 2. UNDERSPEED MICRO SWITCH | 14. GREASE RECESSES (ROLLER BEARING) |
| 3. FRAME | 15. GOVERNOR HOUSING |
| 4. A.C. STATOR ASSEMBLY | 16. TAIL END COVER ASSEMBLY |
| 5. SHAFT ASSEMBLY | 17. DRIVING END COVER ASSEMBLY |
| 6. DRIVING END—END PLATE | 18. COOLING FAN |
| 7. ROLLER BEARING | 19. CONDENSERS |
| 8. A.C. ROTOR | 20. TAIL END COVER SECURING STRAP |
| 9. D.C. EXCITER ARMATURE | 21. PLUNGER AND STRIKER ASSEMBLY |
| 10. EXCITER FIELD ASSEMBLY | 22. ADJUSTING SLEEVE AND SPRING ASSEMBLY |
| 11. SLIPRINGS | 23. GREASE RECESS (BALL BEARING) |
| 12. BRUSHGEAR MOUNTING PLATE | 24. BAFFLE PLATE |

Note . . .

The majority of numbers in key cross refer to the corresponding paragraphs which deal with the description of the components or sub-assembly in the text.

Fig. 2. Generator, Type 163, sectional assembly

RESTRICTED

Sliprings

11. Mounted on the shaft adjacent to the commutator are two sliprings, on to which is fed the generator exciter current. Two insulated supply leads to the rotor pass along machined slots in the shaft inside the armature, they are brazed at one end to each slipring connector and at the other to each rotor field connection. The inner slipring is positive and the other, the negative.

Slipring brushgear

12. The slipring brushgear comprises one positive and one negative brush box each carrying a single brush. Connections are made from the brushes and from the d.c. exciter to terminal posts adjacent to the brush boxes. The brush boxes and terminal posts are mounted on a mounting ring and this assembly is secured to the t.e. face of the brushgear mounting plate.

D.C. exciter brushgear

13. The d.c. exciter brushgear comprises two positive and two negative brush boxes each carrying a single brush. The brush connections are made to terminals on the brush boxes. The two positive brushes are connected together by a commoning link and the two negative brushes are connected together in a similar manner. Connections are made from the brushes to the capacitors, one from the positive to the positive capacitor and the other from the negative to the negative capacitor. The brush boxes are mounted on a mounting ring which is secured to the opposite face of the brushgear mounting plate from the slipring brushgear. The combined d.c. exciter and slipring brushgear assembly is mounted in the frame between the exciter field and the t.e. and when in position is secured by four 2 B.A. hexagon headed bolts which pass through the brushgear mounting plate and frame locating into nuts and these are locked by tab washers.

Tail end bearing

14. The outer race of the ball bearing supporting the t.e. end of the rotor shaft is a push fit into a steel flanged bearing bush

mounted in the extreme t.e. of the frame. The inner race of the ball bearing is a push fit on the rotor shaft and is held in position on the shaft by the carrier for the governor weights. Between the inner race and the carrier is fitted a locking ring, an integral key on its inner diameter locates in a machined slot in the shaft. The carrier is screwed on to the shaft and locked in position by peening over the outer flange of the locking ring into three dimples spaced round the outer edge of the carrier. The inner bearing cap is held in position by the split t.e. bearing cap clamp, this is secured by six 2 B.A. hexagon headed bolts. Three alternate bolts pass through the flanged bush and frame locating into the bearing cap clamp, the three other bolts are also utilized to secure the governor housing to the frame and pass through the housing, flanged bush and frame locating into the clamp. The six bolts are locked by tab washers. The outer race of the bearing is held in position by the inner bearing cap on one side and on the other by the governor housing.

Governor assembly

15. Contained inside the governor housing is the governor assembly. This consists of three identical stainless steel weights which are pin mounted to the carrier attached to the shaft and are free to swivel in an outward direction. When acted upon by centrifugal force due to the rotation of the shaft, the weights move out and cause a plunger, housed in a bush in the hollow end of the shaft, to slide axially and operate a striker pin, this presses on the plunger of a micro switch. The striker pin is supported by a ball bearing and its movement is controlled by the action of a spring housed in a sleeve. The sleeve is screwed into the governor housing and can be adjusted to vary the compression of the spring. The flanged rim of the sleeve is serrated and in conjunction with a retaining clip is used as the method of locking the sleeve after any adjustment has been made. The adjustment determines the r.p.m. at which the governor operates. Located and secured at the extreme end of the governor housing is the micro switch, connections from the switch are taken to

the terminal block. The governor housing is secured to the frame by three 2 B.A. bolts, see details in para. 14. The ball bearing supporting the striker pin is packed $\frac{1}{2}$ full of grease D.T.D. 825 (X.G.275 Ref. No. 34B/9100512) for lubrication.

Tail end, cover assembly

16. The t.e. cover assembly consists of a closed conical shaped cover, flanged at the open end (for mounting to the generator) and is fitted with a pipe. When in position on the generator the cover encloses the commutator, sliprings, brushgear and governor assemblies and is secured by a strap to the frame. The strap securing screw is wire locked after tightening. The pipe is for use as a cooling air inlet and the cover can be rotated to enable the inlet to be positioned to satisfy individual aircraft ducting installations.

Drive-end cover assembly

17. The d.e. cover assembly, consists of a strap fitted with a pipe and a hinged locking pin for securing the assembly to the generator. The cover is fitted round the d.e. endplate within a register and locates to encircle the cooling fan. The pipe is for use as a cooling air outlet and the cover can be rotated to enable the outlet to be positioned to satisfy individual aircraft ducting installations.

Cooling

18. The generator is cooled by an integral fan mounted at the d.e. of the shaft, this draws air through the inlet in the t.e. cover, which circulates inside the machine and is exhausted by the fan through the d.e. cover outlet. The fan consists of two main components, the fan ring and blades and a

deflector plate and hub. The deflector plate and hub and baffle plate (see para. 6), both assist the direction of the flow of air through the fan blades. The fan is keyed to the shaft adjacent to the a.c. rotor and is locked in position (axially) by a circlip.

Capacitors

19. The generator is fitted with four radio interference suppression capacitors; these are held in position on the frame by clamps in pairs, diametrically opposite each other. The clamps are secured by 2 B.A. bolts locating in the frame and locked by tab washers. Connections are taken from the capacitors to the terminal block.

SERVICING

General

20. In the following paragraphs where types, quantities and measurements of materials are detailed or quoted under Leading Particulars, reference should also be made to the relevant servicing schedule. Before installation the generator should be checked to ensure that all screws, bolts and electrical connections, are tight and free from corrosion, and that the rotor assembly is free to rotate. During overhaul, when servicing the rotor assembly, care should be taken not to distort the fan when removing same. Three 2 B.A. tapped holes are provided in the fan hub to assist in withdrawing the fan from the shaft. When fitting the governor weights and carrier assembly to the rotor, do not use the governor weights for tightening purposes. Jointing compound D.T.D. 369 should be used on all jointing faces during assembly. The splines of the drive should be treated with Regent Caltex Crater Compound No. 2.

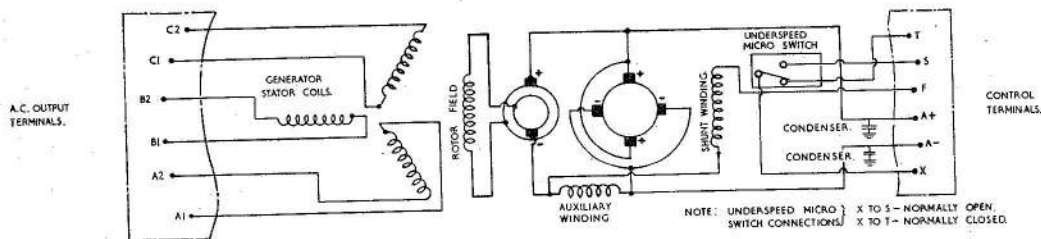

Fig. 3. Internal circuit diagram

RESTRICTED

Carbon brushes

21. The carbon brushes should be checked at regular intervals to ensure sufficient length and freedom of movement in their respective brush boxes. New brushes should be fitted if the rate of wear indicates that the minimum length, as quoted under Leading Particulars, may be reached before the next servicing period or examination. To examine the brushes the t.e. cover assembly must be removed.

Commutator and sliprings

22. The minimum commutator and slipring diameters should be strictly adhered to if it has been necessary to skim these items during servicing. Where it has been necessary to skim the commutator the mica should be undercut to the depth quoted in the Leading Particulars.

Lubrication

23. The bearings should be inspected at the

periods specified in the appropriate Servicing Schedule. They should be thoroughly cleaned, and all traces of old lubricant removed. The driving end bearing, the bearing cap and the recess in the d.e. endplate should each be filled to one third full with grease D.T.D. 783 (X.G.271. Ref. No. 34B/9100510). The tail end bearing and the inner bearing cap should each be filled to one third full with the same lubricant.

Underspeed governor

24. The governor weights are identical and have a critical weight, therefore only slight damage may result in difficulty to obtain a correct governor setting during final tests on the generator. Any suspect weight should therefore be changed during servicing. The governor should be set to close the micro switch contacts as the speed increases at 7360 r.p.m. and to open the contacts as the speed decreases at 7040 r.p.m. A coarse setting can be made by adjusting the micro switch (its attachment bolts are located in

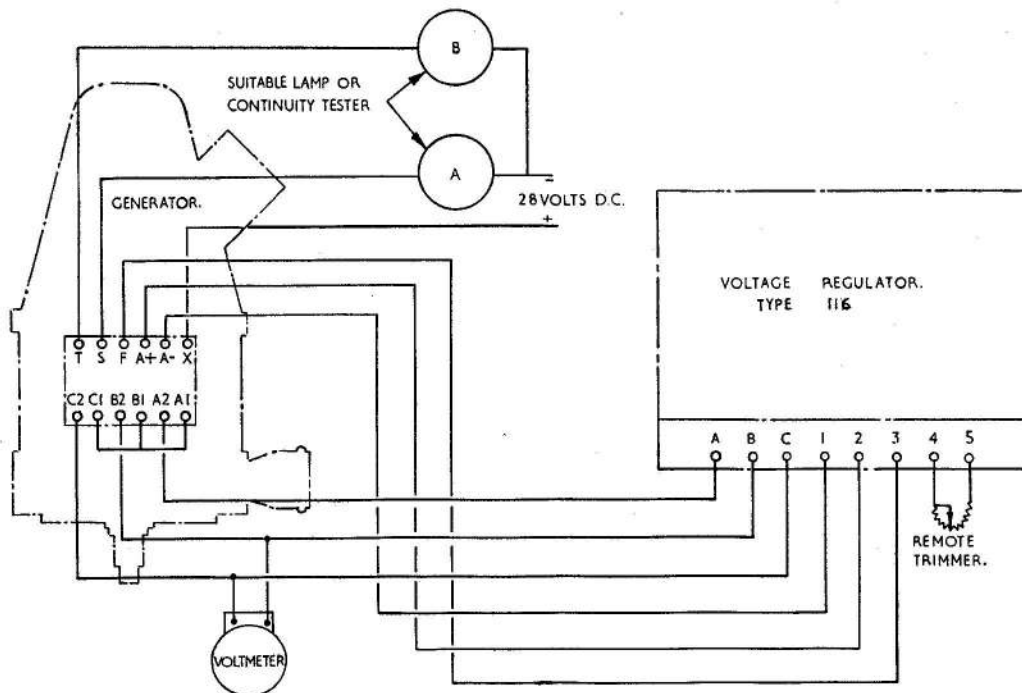

Fig. 4. Test circuit diagram

RESTRICTED

slotted holes); but the final fine adjustment is made by screwing the governor spring sleeve inwards or outwards i.e. to raise the speed turn the sleeve clockwise and to lower the speed turn the sleeve anti-clockwise. When the correct speed has been obtained ensure the sleeve is locked by the retaining clip and the micro switch securing nuts and bolts are tightened, then re-check the setting. Micro switch connections and position of contacts are given in fig. 3.

TESTING

No load test

25. Mount the generator on a suitable test bench and connect as shown in fig. 4, using a Type 116 voltage regulator of proven serviceability. With the generator driven at 8000 r.p.m. the output voltage should be regulated at 200 volts, plus or minus 4%.

Governor micro switch setting

26. The governor micro switch setting should be checked periodically, by using continuity testers or lamps connected as shown in fig. 4. The indications given during test should be as follows:—

- (a) Generator at rest A shows open circuit, B shows continuity
- (b) Generator speed increasing to nominal 8000 } At 7360 r.p.m., A shows continuity, B shows open circuit
- (c) Generator speed decreasing from nominal 8000 r.p.m. } At 7040 r.p.m., A shows open circuit, B shows continuity.

Insulation test

27. Using a 500V insulation resistance tester, check the insulation resistance of the following items. The minimum permissible reading should be not less than 50000 ohms between the windings and earth.

- (a) Stator coils
- (b) Rotor
- (c) Exciter windings

Note...

Care must be taken to ensure that all radio interference suppression capacitors are disconnected before checking the rotor and exciter windings when using a 500 volt insulation resistance tester.

RESTRICTED

This file was downloaded
from the RTFM Library.

Link: www.scottbouch.com/rtfm

Please see site for usage terms,
and more aircraft documents.

