

Introduction

1. The Type 168 generator is an oil-cooled, brushless machine designed to provide a 200V, 3-phase, 400 c/s supply when driven by a constant speed drive at 6000 r.p.m.

DESCRIPTION

General

2. The generator is an 8-pole machine employing main and pilot exciters which are mounted on the same shaft as the generator rotor to provide an integral rotating assembly. Six silicon diodes which rectify the main exciter output are mounted on the rotor shaft making the complete rotor assembly a self-contained unit. The frame which carries the cooling oil houses the generator stator, main exciter stator and pilot exciter stator assemblies. The machine is attached to the constant-speed drive by a quick-release manacle flange.

Rotor assembly

3. The hollow rotor shaft has eight salient poles on which are secured the rotor coils and pole tips. Adjacent to the wound rotor and at the tail end of the machine, the main exciter rotor assembly is fitted, this consists of a fabricated sheet steel rotor carrier on which is mounted the wound exciter rotor assembly. The main exciter winding consists of a double layer lap winding with double

star connection. Six silicon diodes which rectify the output of the main exciter are screwed into the rotor shaft immediately adjacent to the main exciter rotor assembly. The rectified output of the main exciter is connected direct to the alternator rotor, the connecting leads are secured to the shaft and rotor carrier by tying cord.

4. The pilot exciter rotor consists of a ring type permanent magnet which is shrunk into a banding tube. This assembly is fitted between two interleaving magnet claw assemblies which are clamped on the drive end of the rotor shaft. The hollow rotor shaft is manufactured in two parts, the drive-end shaft is splined internally to accept the drive shaft from the constant-speed drive. A silver plates oil tube assembly is inserted in the tail end half of the rotor shaft and the two halves of the rotor shaft are secured together by six $\frac{1}{4}$ in. UNF bolts and located by dowels to form an integral assembly.

Frame and stator

5. The frame is a magnesium-alloy casting, this encloses a helical, oval section steel tube assembly which carries the cooling oil round the frame. The oil supply is connected to the frame by a transfer ferrule which locates in a recess on the frame connected to the generator oil circuit, and provides the connection to the constant-speed drive oil supply. Another

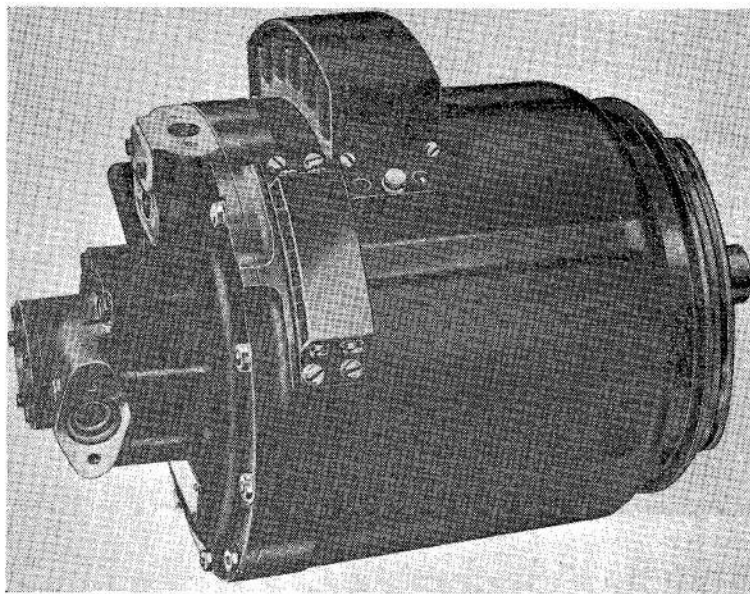
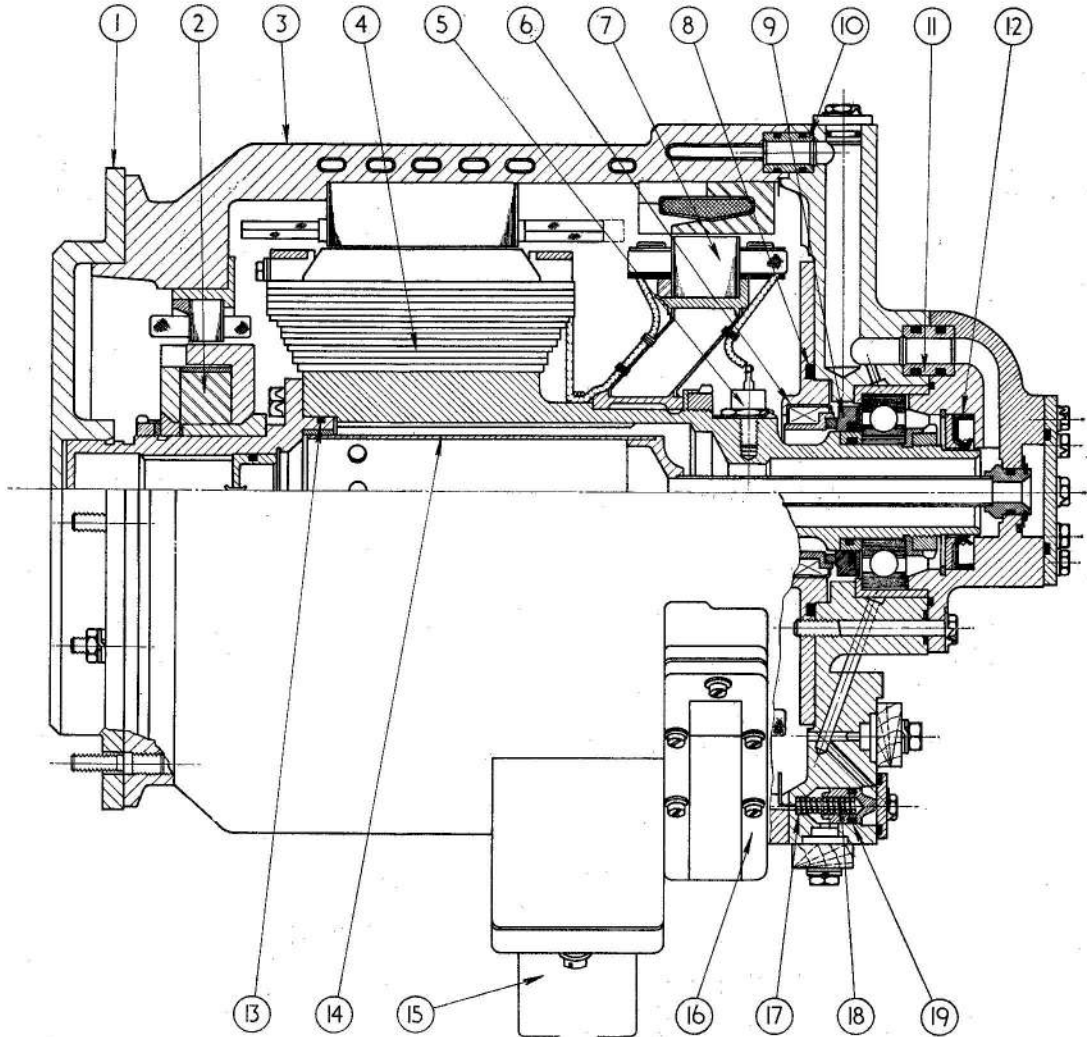

Fig. 1. Generator, Type 168

RESTRICTED



- | | |
|----------------------------------|----------------------------|
| 1 DUMMY END CAP | 11 OIL TRANSFER FERRULE |
| 2 PILOT EXCITER PERMANENT MAGNET | 12 OIL SEAL |
| 3 FRAME | 13 "O" SEAL |
| 4 MAIN ALTERNATOR FIELD | 14 SHAFT OIL TUBE ASSEMBLY |
| 5 SILICON DIODE RECTIFIER | 15 MAIN TERMINAL BLOCK |
| 6 SEALOL SEAL | 16 EXCITER |
| 7 MAIN EXCITER ARMATURE | 17 VALVE SPRING |
| 8 "O" RING | 18 VALVE PISTON |
| 9 INNER MATING RING | 19 SEALING RING-NU-LIP |
| 10 OIL TRANSFER FERRULE | 20 VALVE CAP |

Fig. 2. Sectional view

RESTRICTED

similar ferrule connects the bearing drain outlet on the alternator to the drain connection in the constant-speed drive. Two terminal blocks are mounted on the frame, the larger provides connections for the alternator output and the smaller to both exciters. Both terminal blocks are fitted with clip-on covers moulded in black nylon. The wound stator assembly is shrunk into the frame and then secured in position by keys and locked by pinning. The main exciter stator is secured in a similar fashion. The stator assembly of the pilot exciter is secured in position by six 6 B.A. screws.

Tail-end endplate

6. The endplate is secured to eleven $\frac{1}{4}$ in. UNF studs in the frame end by plain nuts locked with tab washers. The endplate houses the tail-end bearing and also provides the oil passages to transfer the oil supply from the frame to the rotor shaft (via the endcap) and also to the bearing for lubrication purposes. An oilway is drilled in the endplate to provide a drain for the bearing lubricant. The oilway leads to a spring-loaded piston valve housed in the endplate. A 'Sealol' oil seal is attached to the inner face of the endplate. Attached to the endplate is an endcap, the connection to the oil supply is made by means of a transfer ferrule which incorporates two "O" rings. A further oil seal, which seats on the end of the alternator shaft is retained in position in the endcap by an Anderton circlip. One end of the shaft oil tube assembly locates in the endcap, the other end is supported in a phosphorus bronze bush which is shrunk into the rotor shaft assembly.

Ball bearing

7. The single row ball bearing is retained on the shaft by a locknut on the rotor shaft. Shims are fitted between the bearing outer race and the endcap spigot to give a nip in the bearing housing. A "Sealol" oil seal is fitted on the drive side of the bearing. This seal consists of an inner and outer mating ring fitted to the rotor shaft and against which the oil seal bears. The oil seal is retained in position by five $\frac{1}{4}$ in. UNF bolts which pass through the endcap and endplate and locate in tapped holes in the seal housing. Another oil seal is fitted on the tail-end side of the bearing and is retained in position by a circlip located in the endcap.

◀ Cooling system

8. Oil is fed from the constant speed drive oil outlet, via a transfer ferrule, to the helical

oil tube assembly incorporated in the frame casting. The oil passes through the frame, absorbing heat in doing so and is then transferred to the tail-end endplate by means of a transfer ferrule incorporating "O" rings. The oil passes through the oilways in the endplate to the centre of the endcap and then enters the shaft oil tube assembly. The oil flows to the centre of the rotor where it is then ejected from the oil tube assembly via holes in the tube, passes along the rotor shaft towards the main oil outlet. A supply is then taken to the tail-end bearing for lubrication purposes, after passing through the bearing this oil is returned to the constant speed drive via the bearing drain transfer ferrule. The remainder of the oil passes via the main outlet to the constant speed drive oil system for cooling and filtration prior to recirculation. The oil therefore passes around the stator and into the rotor, in doing so, it absorbs heat and transfers it through the system oil cooler, thereby maintaining the generator at a safe working temperature. ▶

9. The oil which is tapped from the cooling circuit for bearing lubrication purposes passes along an oilway to the bearing. From the bearing the oil flows along an oilway via a transfer ferrule to a tube cast within the frame which leads to the constant-speed drive oil circuit. ◀ The generator is connected to a low pressure air supply which maintains the interior of the generator at approximately 9 to 11 p.s.i.g. when the generator is operating. ▶ When the generator is stationary the air escapes via the bearing drain.

10. When the generator starts rotating the piston valve closes due to the oil pressure acting on its face, this seals the air outlet and allows the internal air pressure to attain the normal working value. When the generator ceases rotating the oil pressure falls to zero, this allows the piston valve to open and releases the air pressure inside the generator via the bearing drain, the opening of the piston valve allows any leakage oil which may have accumulated in the bearing drain pipe to be purged by the air pressure from the generator case and discharged from the system.

OPERATION

11. When the generator rotor commences to rotate the permanent magnet rotor of the pilot exciter induces a 1600 c/s output in its armature. This output is connected to the main exciter field via the voltage regulator which rectifies the 1600 c/s output, amplifies it, and controls the output to the main exciter

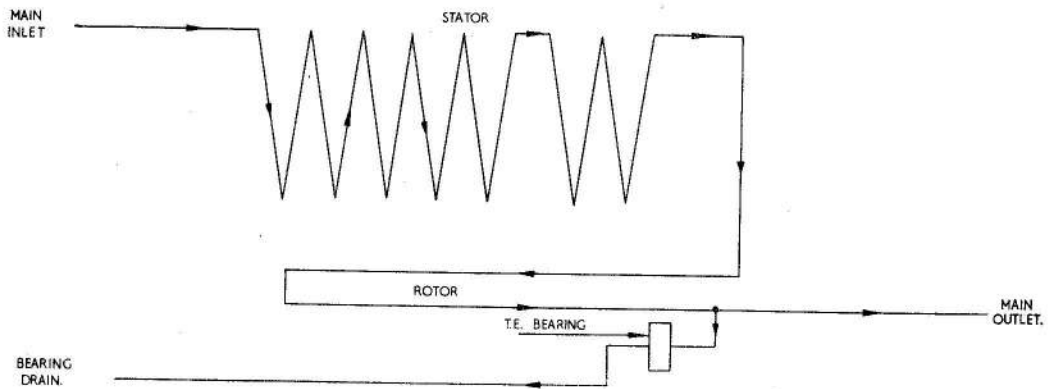
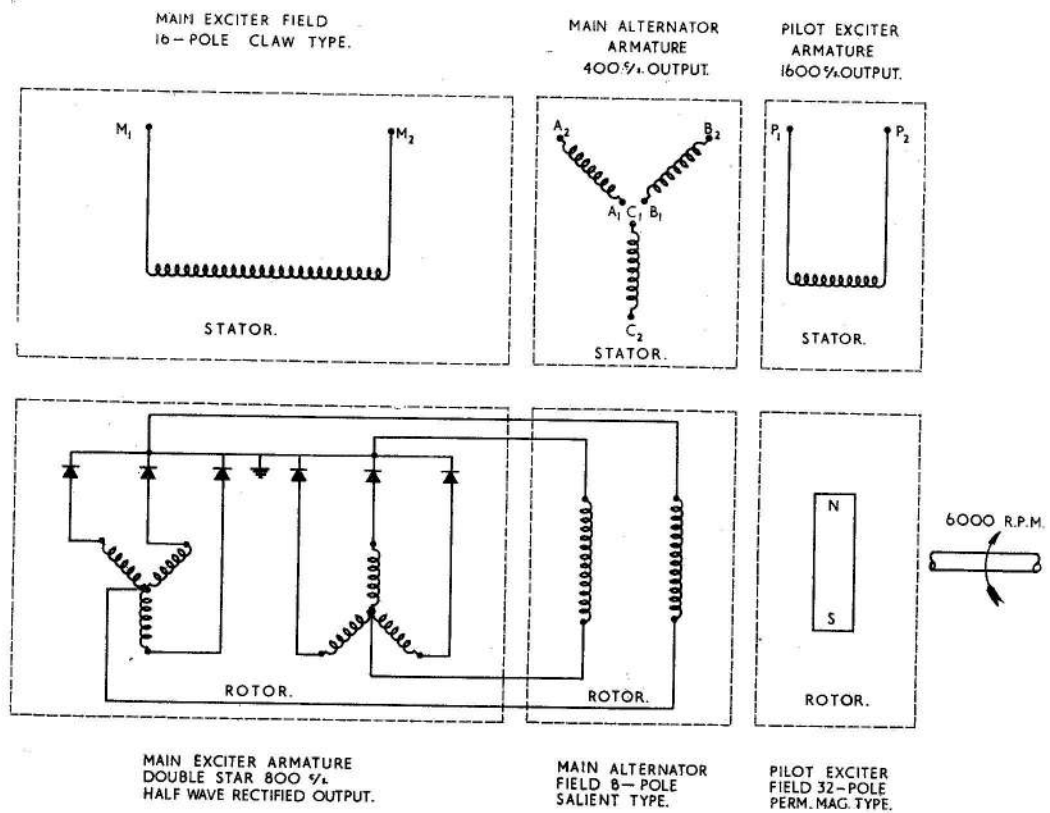

Fig. 3. Oil circuit



THE PILOT EXCITER OUTPUT P_1 - P_2 IS CONNECTED TO THE MAIN EXCITER FIELD M_1 - M_2 VIA THE AE.7301 MAGNETIC-AMPLIFIER REGULATOR WHICH RECTIFIES THE 1600 % PILOT EXCITER OUTPUT AND CONTROLS THE MAIN EXCITER FIELD CURRENT.

Fig. 4. Circuit diagram

RESTRICTED

field. The field of the main exciter induces an 800 c/s output in its rotor. This output is rectified by the silicon rectifiers mounted on the rotor shaft before being fed to the main generator field windings. The main generator field induces a 400 c/s output in the main generator armature which is connected to the load via control gear. The generator output is therefore independent of external sources of supply, making the generator and regulator independent electrical units.

INSTALLATION

12. The generator is not designed for removal or installation without the associated constant-speed drive Type AE.8008. Care should be exercised when mating the two

components that the generator drive and oil transfer ferrules are correctly located. It is essential that the dummy end cover is retained in position on the generator at all times and only removed immediately prior to installation.

SERVICING

13. Little servicing can be effected whilst the generator is in service other than a visual check for mechanical damage and an examination to determine the general security of electrical connections, terminal blocks and oil and air pipe connections. Inspect the machine for oil leaks. The tail-end endplate must not be removed unless equipment is available for lapping and checking the oil seal.

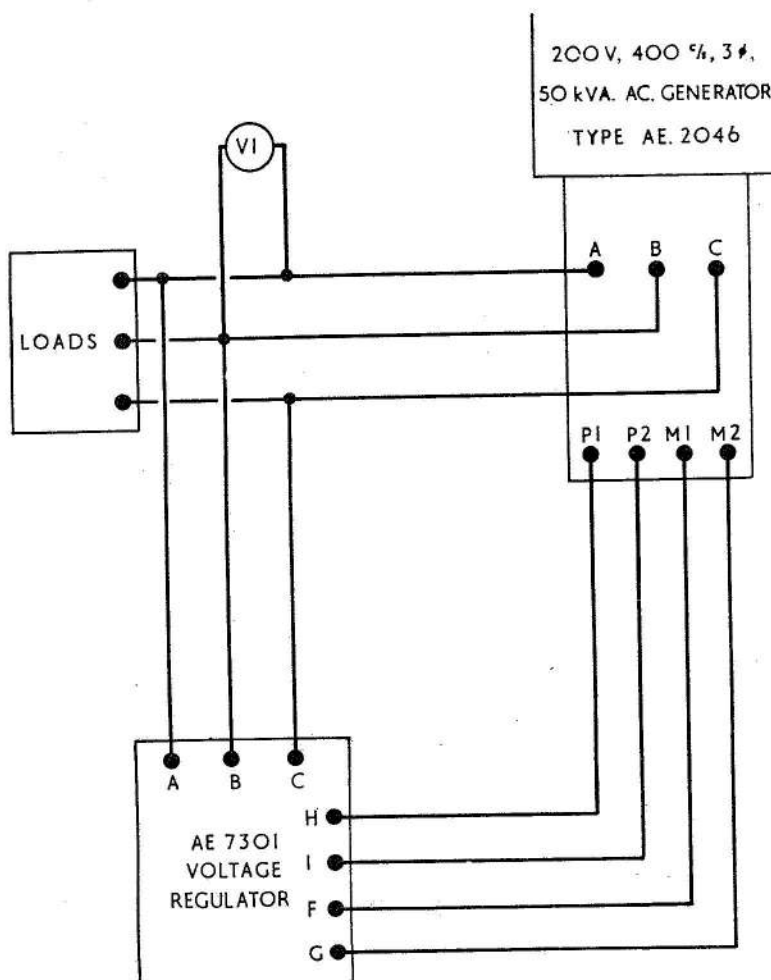

Fig. 5. Test circuit

RESTRICTED

TESTING**General**

14. Measure the resistance of the following windings:—

Main generator stator per phase	0.0243 ohm $\pm 10\%$
Main exciter field	2.75 ohm $\pm 10\%$
Pilot exciter stator	0.22 ohm $\pm 10\%$

Functional test

15. Mate the generator with a slave constant-speed drive Type AE8008 and mount the assembly on a suitable test rig. Run the generator at 6000 r.p.m. with an oil inlet

temperature of 100°C. Pressurize the generator case at 6 to 8 p.s.i.g. Set the line voltage at 200 volts by adjusting the trimmer of the reference circuit; with the machine rotating in a clockwise direction when viewed from the drive end the phase sequence should be A-B-C. The line voltage on no load must be within 201 ± 2.3 volts. Check the line voltage under the following load conditions: 12.5, 37.5, 50 and 62.5 kVA at 0.75 p.f.

The line voltage is to remain at 200 ± 4 volts. The no load voltage must be within 201 ± 2.3 volts. Check the internal oil leakage from the tail end bearing, this must not exceed 5 c.c. per hour.

RESTRICTED

)

)

)

)

This file was downloaded
from the RTFM Library.

Link: www.scottbouch.com/rtfm

Please see site for usage terms,
and more aircraft documents.

