

Now 113 B-0113-1

CHAPTER 19
GENERATOR, B.T.H., TYPE LA3016, FORM B/5

LIST OF CONTENTS

	Para.		Para.
Introduction	1	Brush gear	21
Description		End cover and oil shield	22
Frame	2	Air and oil seal	23
Stator	3	Slipring end bearing	24
Rotor	4	Assembly	
Oil seals	7	Drive-end housing	25
Brush gear	8	Rotor	26
Installation		Slipring end bearing	27
Servicing		Air and oil seal	28
General	10	Brush gear	29
Routine servicing	11	Rotor and drive-end housing	30
Brushes	12	End cover and oil shield	31
Sliprings	13	Testing	
Bay servicing	14	General	32
Dismantling	16	Resistance tests	34
Rotor and drive-end housing	18	Brush bedding	35
Rotor	19	Running tests	36
Drive-end housing	20	Insulation resistance test	37

LIST OF ILLUSTRATIONS

	Fig.
Generator, Type LA3016, Form B/5	1
Sectional view	2
Exploded view	3

LEADING PARTICULARS

Generator, Type LA3016, Form B/5	Ref. No. 5UA/7437
Output voltage	3-phase 26V a.c.
Output current 312A
Frequency	400 c/s at 8,000 rev/min.
Excitation voltage 24V d.c.
Speed range	3,920-10,100 rev/min. ▶
Brush grade K.E.E.G.12 ▶
New brush length $\frac{31}{8}$ in.
Minimum brush length (on longest side) $\frac{9}{16}$ in.
Rotation viewed from drive end	Counter-clockwise
Cooling air required at ground level 15 lb/min.
Sliprings	
New diameter	2-752-2-748 in.
Minimum diameter 2-525 in.
Weight 79 lb. 4 oz.

RESTRICTED

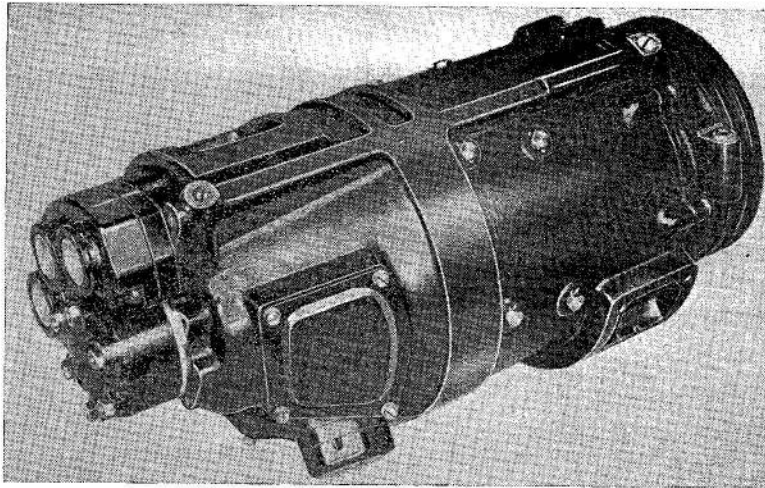

Fig. 1. Generator, Type LA3016, Form B/5

Introduction

1. The Type LA3016, Form B/5 a.c. generator (*fig. 1*) is an engine driven, blast cooled machine designed to supply power over a range of engine speeds as shown in the Leading Particulars.

DESCRIPTION

Frame

2. The main frame is a light alloy machine casting. The drive-end bearing housing, which is secured to the main frame by eight studs and nuts, is a separate light alloy casting arranged for a spigot location on the main frame at one end, and secured by two lugs to the bevel box of the engine gearbox at the other end. Two sealing rings are incorporated to prevent the escape of oil from the bevel box. The slipring end housing is an integral part of the main frame casting.

Stator

3. The stator, which is secured in the main frame by hex. hd. screws, consists of a laminated core wound with a double layer wave winding in semi-closed slots. The winding is delta connected, and is brought out by insulated flexible leads to three special terminal lugs mounted on the main frame casting at the slipring end of the machine.

Rotor

4. The revolving field system consists of six salient poles built up of steel laminations. A squirrel-cage pole face winding is fitted to reduce the effects of the harmonics produced

by the associated rectifiers. This winding consists of three copper bars per pole running through the laminations, and short circuited at each end by copper rings which are braised to the bars.

5. The excitation windings are insulated with silicone impregnated material, and the two lead end connections from the series connected coils are brought out to the two sliprings. Built-in permanent bar magnets provide the initial flux required to excite the stator winding sufficiently to generate a voltage through the main rectifiers and feed-back into the field system.

6. The rotor is mounted on a roller bearing at the slipring end and ball journal bearing at the drive end. Both bearings are lubricated with oil which is supplied from the engine gearbox. Oil flows into the hollow shaft of the rotor and is directed onto the bearings by holes drilled through the shaft wall. After the oil passes through the drive-end bearing it is returned to the gearbox. The oil from the slipring end bearing returns to the gearbox through holes machined in the main frame casting.

Oil seals

7. An air and oil seal is fitted at each end of the rotor shaft and the pressurized air inlet is machined in the fixing strap pad on the outside of the main frame casting. Air, pressurized from the fourth stage of the turbine compressor, flows along passages machined in the frame casting. After passing through

RESTRICTED

cavities around the seals, the air enters the sealing surface through holes drilled at right-angles to the seal. The combination of air pressure and the pumping action of the threads in the seal prevents oil seeping back along the shaft and contaminating the slipping surfaces or damaging the windings.

Brush gear

8. The four brushes are held in two pairs of handed brush boxes, which are fitted to a brush plate, two brushes being spaced at right-angles to each other on each slipring. Each brush is held in position on the slipring by an arm, whose two springs are so placed that an even pressure is maintained on the brush throughout its life. The brushes on each slipring are connected by a paralleling link, and the lead from each pair of brush boxes is connected to a capacitor which is earthed to the frame casting, and provides radio interference suppression. Access to the brush gear is provided by cover plates on the frame.

INSTALLATION

9. The generator is secured to the engine by a strap which passes round the frame casting. The spigot of the generator locates in the bevel gearbox and two bolts secure the spigot end to the bevel box. The actual mounting position and the method of coupling the generator to the engine gearbox are described in the appropriate section of the Aircraft Handbook.

SERVICING

General

10. The generator should be serviced in accordance with the relevant servicing schedule and the instructions contained in this chapter.

Routine servicing

11. Little routine servicing can be accomplished between bay servicing periods, other than to check the security of all screws, bolts, electrical connections and to examine the machine for signs of oil leakage.

Brushes

12. The brushes should be checked at the periods described in the relevant Servicing Schedule to ensure sufficient length and freedom of movement in the brush boxes. New brushes should be fitted if the rate of wear

indicates that the minimum length may be reached before the next servicing period or examination. If new brushes are fitted, each brush should be bedded to at least 75% of its contact area. The procedure for bedding is given in para. 35.

Sliprings

13. Examine the sliprings for signs of burning and contamination. If the rings are badly worn or pitted the generator should be removed for dismantling and skimming.

Bay servicing

14. The servicing checks detailed in the following paragraphs should be performed when the generator is removed from its installation. Bay servicing after the generator has been dismantled includes the following checks.

- (1) Examine all components for damage, cracks or fractures, corrosion or contamination and insecurity of attachment.
- (2) Clean all components in lead-free gasoline and using a jet of dry compressed air.
- (3) Check that all air or oil holes in the castings are unobstructed.
- (4) Examine the air and oil seals for signs of rubbing of the sealing surfaces.
- (5) Examine the bearings for signs of cracking, pitting or wear of the balls or races. Wash the bearings in lead-free gasoline and dry using a jet of dry compressed air.
- (6) Check that the cowl seal is securely fitted on the cowl and that the seal shows no signs of deterioration or rubbing of the sealing surface.
- (7) Examine all wiring and windings for any external signs of burning or damaged insulation.

15. When the generator is removed, it should be maintained in the relative horizontal position with the arrow at the slipping end cover pointing downwards, for 15 minutes. After 15 minutes in this position, the generator should be allowed to stand for a further 30 minutes in a vertical position with the drive end downwards. This ensures that the oil is drained completely from the machine.

Dismantling

16. Dismantling the generator should not be attempted unless the special tools required

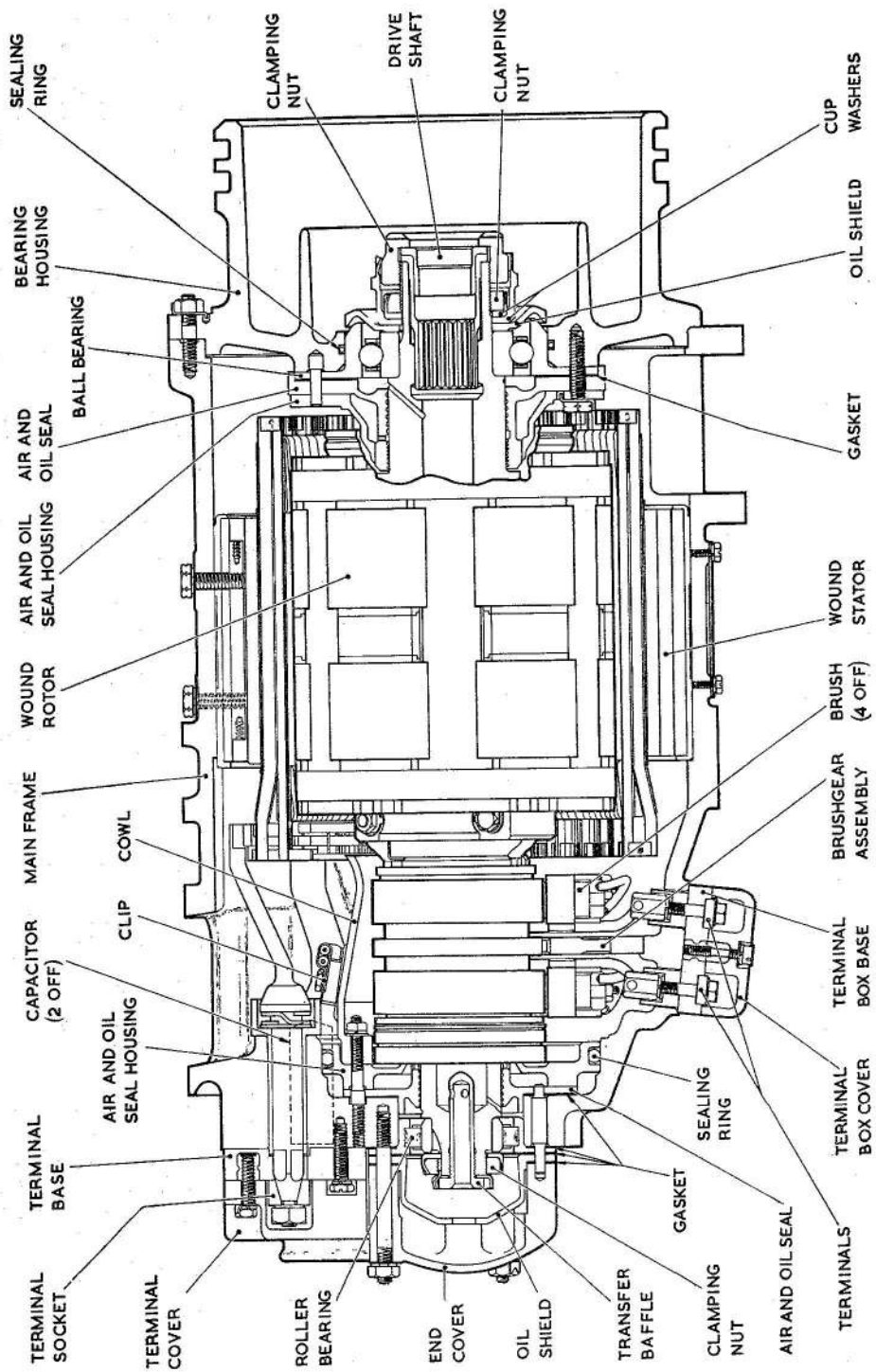

Fig. 2. Sectional view

RESTRICTED

are available. The following tools or their equivalents should be used.

Description	Drawing Reference
Drift for removal of air and oil seal (slipping end)	CX133280-23
Spanner for clamping nuts (drive end of shaft)	CX170436
Spanner for transfer baffle	CX170437
Spanner for clamping nut (slipping end of shaft)	CX170438
Extractor for inner race (slipping end of shaft)	CX170439

17. A guide to the dismantling procedure is given in fig. 3 which shows an exploded view of the generator completely dismantled.

18. *Rotor and drive-end housing.*—Remove the four screws securing each brush-box inspection cover and lift off the cover and gasket. By using a suitable piece of bent wire or a hook, lift each brush on, remove the brushes and temporarily trap them across the brush-box slot with the brush retaining arm. Unlock and remove the nine $\frac{1}{4}$ in. B.S.F. nuts and locking tab washers which secure the drive-end bearing housing to the main frame. Withdraw the rotor and drive-end housing from the main frame. The main frame should be held in an upright position and the drive-end housing lightly tapped until it is released from the main frame. Extreme care should be exercised when withdrawing the rotor assembly to avoid damage to the air and oil seals.

19. *Rotor.*—Remove the rotor from the drive-end housing as follows:—

- (1) Unlock the first clamping nut at the drive-end of the shaft by gently tapping out the cup washer from the slots in the nut. Unscrew this nut.
- (2) Unlock and remove the inner clamping nut in a similar manner. Remove both cup washers, the drive shaft and the oil shield.
- (3) Gently tap the bearing housing away from the rotor, taking care not to damage the oil seal.

20. *Drive-end housing.*—Remove the air and oil seal housing assembly from the drive-end housing as follows:—

- (1) Unlock the tab washers and remove the six $\frac{1}{4}$ in. B.S.F. screws securing the air and oil seal housing, the air and oil seal, the gasket and the bearing to the bearing housing.
- (2) With the bearing housing suitably supported, gently tap the bearing out of the housing.

21. *Brush gear.*—The brush gear assembly should be removed from the main frame as follows:—

- (1) Remove the field terminal box, by unscrewing the centre screw.
- (2) Unlock and unscrew the two 2 B.A. screws which are passed through the terminals and into the hexagonal lugs which are fitted on the ends of the leads to the brush boxes. Ensure that the locking washer and plain washer fitted between the tapped hexagon nut and the terminal block base are removed.
- (3) Unlock and unscrew the two 2 B.A. nuts securing the leads to the capacitors. Remove the 2 B.A. hex.hd. screw securing the clip clamping the capacitor leads to the cowl. Remove the four 4 B.A. hex.hd. screws securing the capacitors and lift out the capacitors.
- (4) Remove the three 2 B.A. hex.hd. screws which secure the brush gear to the frame and withdraw the brush gear.

22. *End cover and oil shield.*—Remove the end cover as follows:—

- (1) Unlock and unscrew the six $\frac{1}{4}$ in. B.S.F. nuts securing the end cover and oil shield to the frame.
- (2) Gently tap the end cover away from the casting, this will remove the oil shield and expose the outer race.
- (3) Remove the outer race and rollers and the three gaskets.

23. *Air and oil seal.*—Remove the slipping end air and oil seal as follows:—

- (1) Remove the eight 2 B.A. nuts securing the cowl, air and oil seal housing, air and oil seal and gasket. Lift out the cowl.
- (2) Gently tap out the air and oil seal from the outside of the frame. Remove the gasket from inside the frame. This will also remove the air and oil seal housing and its associated sealing ring.

24. Slipping end bearing.—If it is necessary to remove the bearing, the inner race of the roller bearing should be removed as follows:—

- (1) Unlock the transfer-baffle cup washer and unscrew and remove the baffle.
- (2) Unlock and remove the clamping nut securing the inner race to the rotor shaft.
- (3) Fit the extractor to the end of the shaft and over the inner race, and remove the inner race.

Assembly

Note . . .

Great care must be taken when fitting the rotor shaft through the air and oil seal in the housing. Any marking, however minute, on the surfaces of this seal, will cause leakage.

25. Drive-end housing.—Fit the sealing ring, ball bearing, gasket and air and oil seal housing to the drive-end housing as follows:—

- (1) With the double grooved end of the bearing housing placed on a flat surface, fit the sealing ring into the annular groove machined in the bearing recess.
- (2) Gently tap the ball bearing into position, locating it on the dowel in the housing. Liberally coat the bearing with oil OX-38.
- (3) Fit the gasket and air and oil seal housing, locating them on the dowel. Secure the four items to the bearing housing by fitting six $\frac{1}{4}$ in. B.S.F. screws, each screw being fitted with a locking-tab washer. Tighten up evenly and lock the screws.

26. Rotor.—Fit the rotor to the drive-end housing as follows:—

- (1) Fit the driving end of the rotor to the bearing housing. Position the rotor shaft very carefully into the bearing holding the rotor vertically. The weight of the rotor will start the shaft entering the bore of the bearing but the rotor shaft will have to be finally pressed home in a suitable press.
- (2) Fit the oil shield to the driving end of the rotor shaft so that the machined boss is fitted next to the inner race of the driving end bearing.
- (3) Fit the cup washers, one inside the other, and fit and tighten the smaller clamping nut.

(4) Assemble the drive shaft up to the end of the rotor shaft, and fit and tighten the outer clamping nut.

27. Slipping end bearing.—If the roller bearing inner race has been removed, it should be re-fitted as follows:—

- (1) Press the inner race unto the shaft and ensure the race is right home against the shoulder of the shaft.
- (2) Fit the cup washer and clamping nut, tighten the nut and lock.
- (3) Fit the transfer baffle and cup washer, tighten the baffle and lock.

28. Air and oil seal.—Assemble the air and oil seal to the slipping end of the main frame as follows:—

- (1) Fit a new sealing ring into the annular groove around the air and oil seal housing.
- (2) Fit the gasket, then the air and oil seal together with its housing, and the reflector cowl onto the 2 B.A. studs protruding from the inside of the main frame.
- (3) Fit, tighten and lock the eight 2 B.A. nuts and locking-tab washers.

29. Brush gear.—Assemble the brush gear into the main frame as follows:—

- (1) Fit the brush gear into the main frame and locate it on the three machined pads at the slipping end. Fit, tighten and lock the three 2 B.A. screws securing the brush gear.
- (2) Secure each brush pigtail to its respective stud on the brush box and temporarily trap each brush across its brush box slot with the brush retaining arm.
- (3) Fit the two capacitors and tighten and lock the four 4 B.A. securing screws. Reconnect the capacitor leads and secure in position by the 2 B.A. nuts and locking-tab washers. Position the clip clamping capacitor leads to the cowl and tighten and lock the securing screws.
- (4) Ensure that there is a plain washer and locking washer fitted inside each projecting part of the terminal box base, with the plain washer next to the moulding. Fit the two 2 B.A. screws into the terminal box base and screw them into the tapped hexagon nuts soldered to the flexible field connections.

30. Rotor and drive-end housing.—Assemble the rotor and drive-end housing to the main frame as follows:—

- (1) Fit a new sealing ring into each recess in the spigot face of the drive-end of the main frame.
- (2) Place the drive-end housing with the rotor in a vertical position on a flat surface and carefully lower the main frame over the rotor and position frame studs in the drive-end housing.
- (3) After ensuring that the sealing rings have not been displaced, gently tap the frame unit onto the bearing housing spigot. Fit, tighten and lock the securing nuts.

31. End cover and oil shield.—Assemble the roller bearing outer race, oil shield and end cover to the main frame as follows:—

- (1) Fit a new gasket over the six long studs.
- (2) Fit the roller bearing outer race and gently tap it into position. Liberally coat the rollers with oil OX-38. Ensure that the rotor turns freely and easily.
- (3) Fit the oil shield to the end cover with a gasket correctly positioned between them.
- (4) Fit another gasket together with the oil shield and end cover assembly over the studs and locate correctly by the dowel. Fit the six $\frac{1}{4}$ in. B.S.F. nuts and locking-tab washers, tighten up evenly and lock.

TESTING

General

32. When the generator is being run on the test bench provision should be made for the following:—

- (1) Mass flow of air of at least 15 lb/min. must be fed through the cooling inlet of the generator.
- (2) The oil seals are to be provided with air, pressurized to at least 11.5 in. water gauge referred to ground level.
- (3) Oil is to be supplied at the rate of at least 0.5 gall/hour into the end of the shaft.

33. After completion of the tests the generator is to be drained as follows:—

- (1) Place the generator in a horizontal position so that the arrow on the slipping end cover is pointing downwards. Leave in this position for 15 minutes.
- (2) Stand the machine up on its driving-end housing and leave for 30 minutes in this vertical position.

Resistance tests

- 34.** (1) Check that the rotor winding resistance, as measured between the sliprings, is within the limits of 0.58 ohm \pm 10% at 20 deg. C.
- (2) Check that the stator winding resistances, as measured between any two terminals at a time, are within the limits of 0.0036 ohm \pm 10% at 20 deg. C.

Brush bedding

35. Run the generator in a counter-clockwise direction at 8000 rev/min, as viewed from the driving-end, until the brushes are bedded over at least 75% of their area. A current of approximately 5A should be passed through the field windings whilst the brushes are being bedded. Blow out the brush dust with a jet of dry compressed air.

Running tests

- 36.** (1) Run the generator on open-circuit at 8000 rev/min for five minutes. Check that the open-circuit voltages between phases are balanced, and are within the limits of 70V \pm 10% for field current of 20A at a nominal 24V d.c.
- (2) Run the generator on short-circuit at 8000 rev/min and increase the field current to 23A at a nominal 24V d.c. The short-circuit output current under these conditions must be within the limits of 312A \pm 10%.
- (3) Run the generator on open-circuit at 8000 rev/min for five minutes without any field current. Check that the residual voltages between phases are balanced and are within the limits of 6.1V \pm 5%.

Insulation resistance test

37. Check that the insulation resistance values between the stator and rotor windings and the frame are not less than 50 000 ohms when measured with a 250V insulation resistance tester.

RESTRICTED

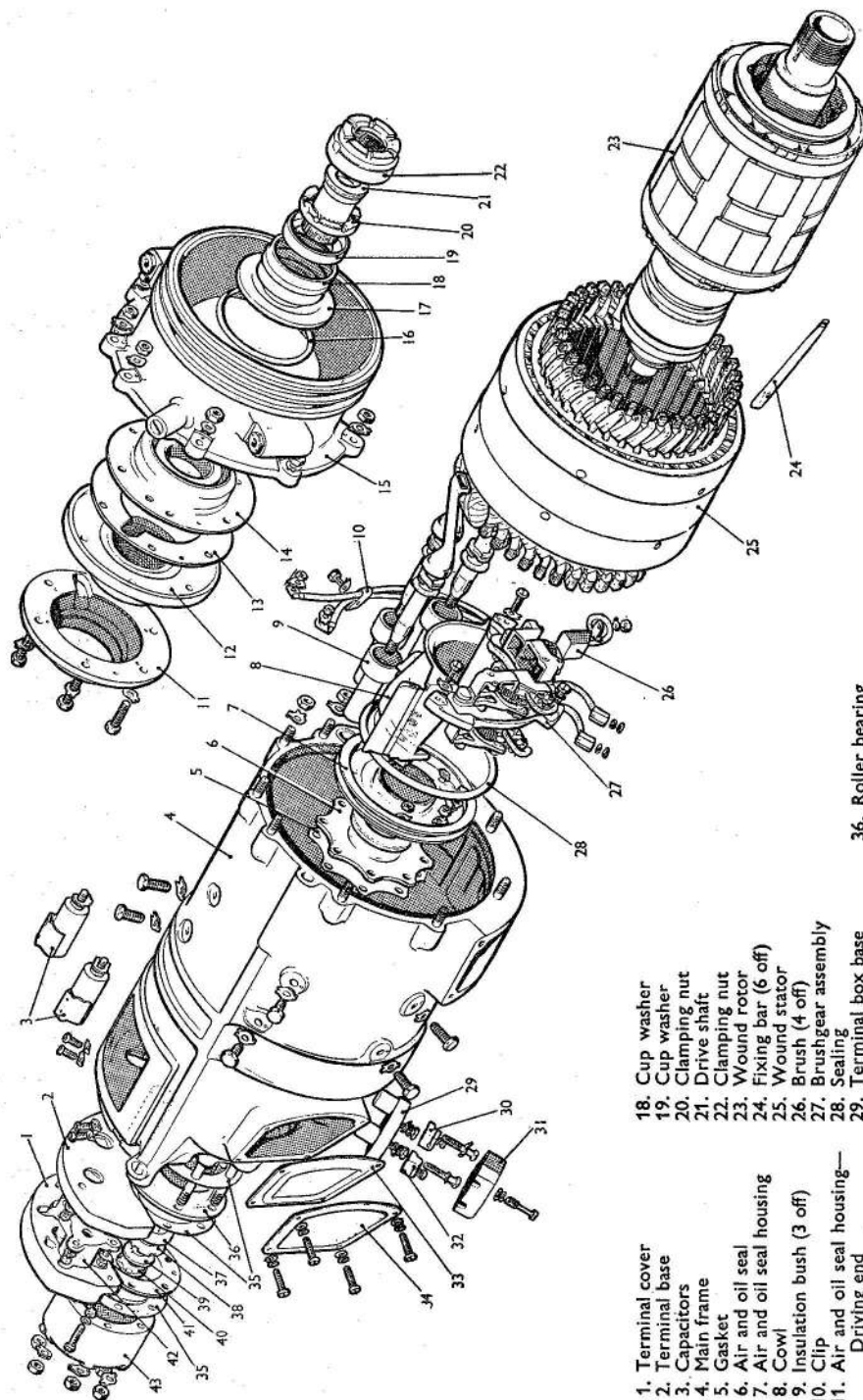

- 1. Terminal cover
- 2. Terminal base
- 3. Capacitors
- 4. Main frame
- 5. Gasket
- 6. Air and oil seal
- 7. Air and oil seal housing
- 8. Cowl
- 9. Insulation bush (3 off)
- 10. Clip
- 11. Air and oil seal housing—
Driving end
- 12. Air and oil seal—
Driving end
- 13. Gasket
- 14. Ball bearing
- 15. Bearing housing
- 16. Sealing ring
- 17. Oil shield

- 18. Cup washer
- 19. Cup washer
- 20. Clamping nut
- 21. Drive shaft
- 22. Clamping nut
- 23. Wound rotor
- 24. Fixing bar (6 off)
- 25. Wound stator
- 26. Brush (4 off)
- 27. Brushgear assembly
- 28. Sealing
- 29. Terminal box base
- 30. Terminal (L.H.)
- 31. Terminal box cover
- 32. Terminal (R.H.)
- 33. Gasket (2 off)
- 34. Brush inspection cover
(2 off)
- 35. Gasket (3 off)

- 36. Roller bearing
- 37. Cup washer
- 38. Clamping nut
- 39. Cup washer
- 40. Transfer baffle
- 41. Oil shield
- 42. Terminal socket (3 off)
- 43. End cover

Fig. 3. Exploded view

RESTRICTED

This file was downloaded
from the RTFM Library.

Link: www.scottbouch.com/rtfm

Please see site for usage terms,
and more aircraft documents.

