

Chapter 21

GENERATORS, ROTAX, BA 1000 SERIES

LIST OF CONTENTS

	<i>Para.</i>								<i>Para.</i>
<i>Introduction</i>	1	Installation							11
Description	3	Servicing							13
<i>Operation</i>	6	<i>Lubrication</i>							17
<i>Electrical connections</i>	10	<i>Testing</i>							18

LIST OF ILLUSTRATIONS

	<i>Fig.</i>								<i>Fig.</i>
<i>General view of typical generator</i>	1	<i>Circuit diagram</i>							3
<i>Sectional view of generator</i>	2								

LIST OF APPENDICES

	<i>App.</i>								<i>App.</i>
<i>Standard serviceability test for generators, Rotax, BA1000 series</i>	A	<i>Generator, Rotax, Type BA1004</i>							1

Introduction

1. Generators in the BA1000 series are continuously rated machines providing 11 kVA, 208 volts, 3-phase, 400 c/s a.c. at 0.95 power factor and are for use in aircraft. The machines are blast cooled at the slip-ring end of the unit, with a free air outlet through ventilation slots positioned around the main housing at the drive end.

2. The generators will operate within a temperature range of -30 deg. C. to +50 deg. C. and at altitudes up to 50,000 ft. Electrical connections are made via a terminal box, located on the outside diameter of the end housing assembly, which accommodates six 2 B.A. terminal posts. Radio interference is suppressed by a system of capacitors ZA3417-ZA3418, housed in the screened terminal box of the unit.

DESCRIPTION

3. A typical generator in the series is illustrated in fig. 1 and 2. The machine consists of a light alloy housing and end frame assembly, which contains the wound

stator, rotor, slip-ring and brush gear assemblies. The stator assembly is contained within the main housing, the windings being star connected with the three-phase and star point connections brought out to a screened terminal box attached to the end frame.

4. The rotor is supported in a ball bearing at each end of the driving shaft, the d.c. excitation supply being fed from the terminal box to the rotor, via two slip-rings each having three brushes fitted. Access to the slip-ring and brush gear assemblies is gained through an inspection cover band fitted on the outside diameter of the end frame.

5. To prevent oil entering the machine from the driving source, an oil seal carried in a housing plate bolted to the main housing is fitted over the shaft at the drive end. The oil seal requires a small but continuous supply of oil to prevent wear to the portion of the seal in contact with the shaft. This is facilitated by a splash or spray feed from the driving source.

RESTRICTED

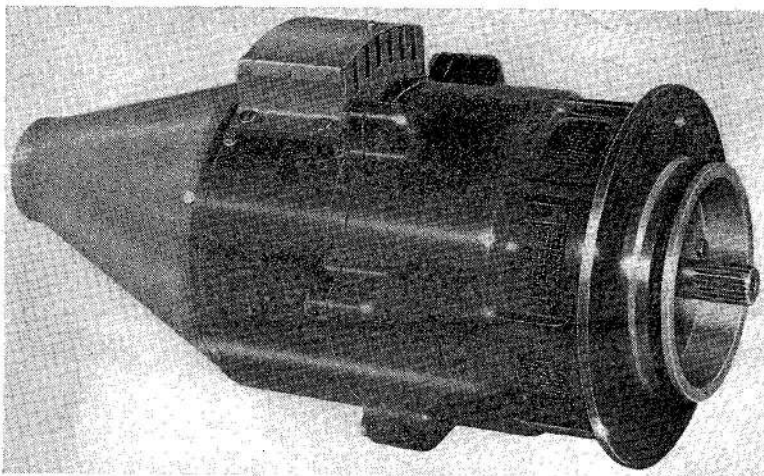

Fig. 1. General view of typical generator

Operation

6. The generator is to be driven in an anti-clockwise direction when viewed from the drive end and supplied with blast air cooling at a pressure drop (static) equivalent to an 8-inch head of water.

7. Input d.c. rotor excitation current is obtained via the regulating resistor of a 28-volt supply. This excitation current is fed

to, and returned from, the rotor winding by means of the two slip-rings and associated spring-loaded brushes.

8. The rotor forming a six-pole electro-magnet is rotated inside the stator windings, and thereby induces into the winding alternating E.M.F.s. Due to the three stator windings being displaced by 120 degrees with respect to each other, these E.M.F.s give a 3-phase alternating current output.

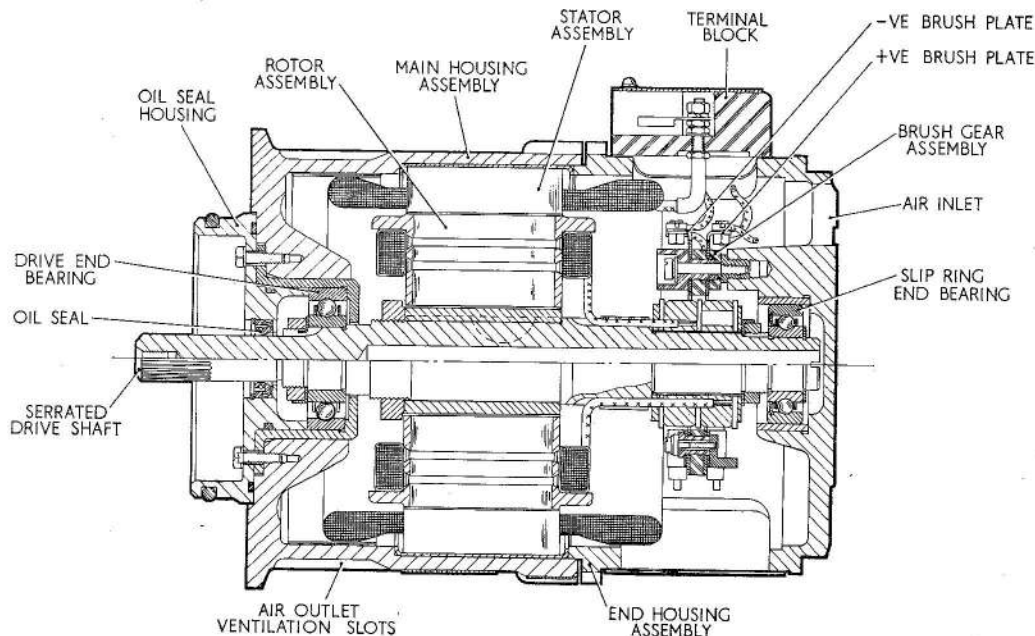

Fig. 2. Sectional view of generator

RESTRICTED

9. This alternating current, as delivered by the generator, can be used for operating 3-phase motors or de-icing equipment, or may be rectified for direct current application.

Electrical connections

10. The star point and the three ends of the stator windings, together with the rotor input leads from the brushes, are taken out to separate terminals of a six-way terminal block; each 2 B.A. terminal is identified as follows:—

N (star point); R, W, and B (a.c. phases);
— and + (rotor input) (*fig. 3*).

INSTALLATION

11. When despatched from the factory, the generator is equipped with a wooden cover bolted to the mounting flange for protection. This cover should be removed before the machine is installed in the aircraft.

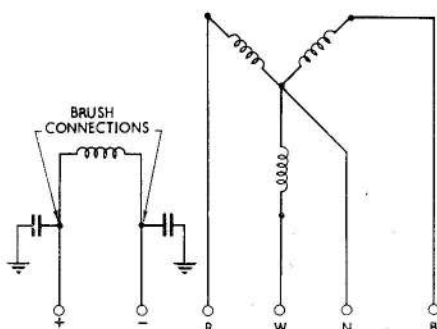

Fig. 3. Circuit diagram

12. For full installation details refer to the appropriate handbook concerning the unit to which the generator will be coupled, together with the following notes:—

- (1) Prior to mounting the generator, test the rotor for freedom of movement.
- (2) Check the fit and security of the coupling to the drive shaft, which on assembly is recommended to be lightly lubricated with grease XG-271.
- (3) Bearings are pressure filled with grease XG-271 and the surrounding space in the bearing housing is also lightly packed with the same grease.
- (4) Relative positions of terminal block and 0.343 in. dia. x 0.312 in. deep dowel hole positioned on a 2.875 P.C.D. in the mounting flange face are important, and

vary for different generators in the series; details will be given in the relevant appendix.

(5) The units are designed to be mounted horizontally ± 5 per cent, by means of a manacle flange and spigot.

SERVICING

13. Remove the inspection cover at the slip ring end. Examine the brushes and remove any carbon deposit with a supply of clean dry compressed air. Check that the brushes are a sliding fit in their boxes and examine for carbon dust in the corners. Remove any carbon with a cloth moistened with lead free gasoline. Check that the length of the brushes are such that they will continue to operate satisfactorily until the next overhaul. The minimum brush length (measured on the long side) is 0.437 in.

14. With a suitable tension gauge, check the pressure of the brush springs. The spring pressure when measured at a point level with the top of the brush box should be between 7 and 10 oz. (199–283 grams).

15. In the event of new brushes being fitted, the generator should be driven at 3,000 r.p.m. and the rotor current set at 8 amp., or a reduced value, if sparking occurs at the slip rings. Each brush should be bedded to at least 50 per cent of the intended contact area.

16. The electrical connections should be examined to ensure that they are secure and free from corrosion. The slip-rings should be examined for scores or burns. If their condition is such that the efficiency is impaired, the machine must be removed for reconditioning or repair.

Lubrication

17. On assembly of the generator, bearings are pressure filled with grease XG-271, and the surrounding space in the bearing housings is also lightly packed with the same grease; this will normally require to be renewed only during assembly after repair.

Testing

18. If the serviceability of this machine is suspect, it may be tested in accordance with the test procedure laid down in Appendix A.

19. On completion of the inspection and servicing, refit the inspection cover and ensure that all screws are securely locked.

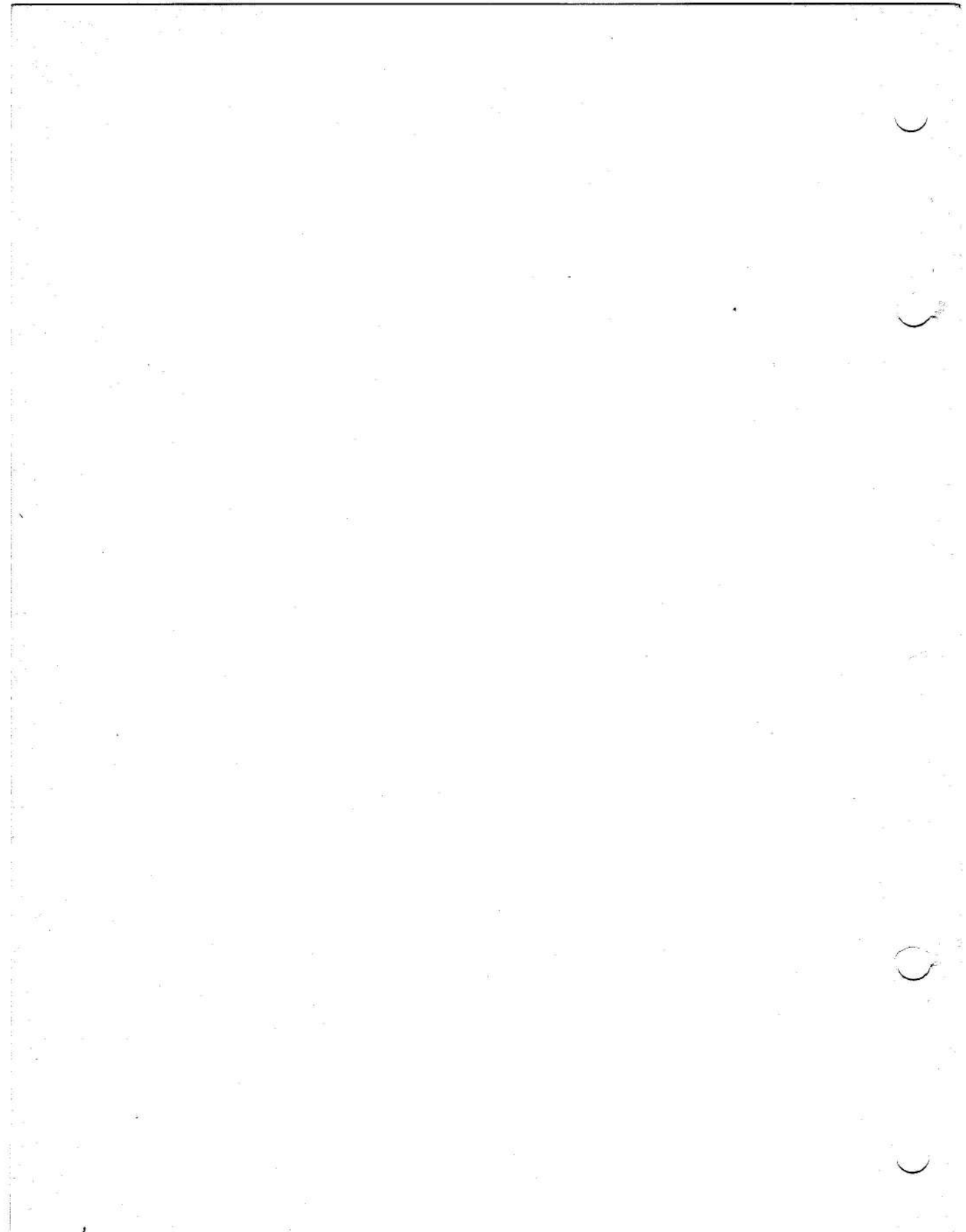

Appendix A

STANDARD SERVICEABILITY TEST FOR GENERATORS, ROTAX, BA 1000 SERIES

Introduction

1. The following tests may be applied to the machine before it is put into service, or at any time when its serviceability is suspect.

Test equipment

2. The following test equipment is required:—

- (1) Tester, generator—one in the Mk. 5 series.
- (2) Balance, spring, 0-4 lb. (Ref. No. 1H/97) or gauge, tension, 100-500 gm. (Ref. No. 1H/86).
- (3) Short-circuit load testing unit (Ref. No. 5G/3055).
- (4) Insulation resistance tester, Type C (Ref. No. 5G/152) (for R.A.F.) or Type 0557/A.P.5047 (for R.N.).

The generator should be driven in an anti-clockwise direction. Blast air should be applied to the air inlet at a pressure equivalent to a head of 8 in. water gauge, and a 28-volt d.c. supply connected to the rotor through a suitable regulating resistor. Care should be taken to avoid breaking the rotor circuit when the excitation exceeds 5 amp.

Testing

3. Before mounting the generator on the test set, check for freedom of rotating parts by turning the rotor by hand without using a coupling. There should be no excessive end play in the bearings; a slight radial play which can just be felt by hand is permissible.

Brushgear

4. Check the brush length and brush spring pressure. The brush length should be not

less than 0.437 in. and the spring pressure should lie between 7 and 10 oz. (199 and 283 gm.).

Phase sequence

5. When mounted and connected as in para. 2, the a.c. output phase sequence should be red, white, blue relative to the terminal markings.

Open-circuited test

6. With the machine driven at 8,000 r.p.m. and the output open-circuited, set the line voltages to an average value of 208 volts by adjustment of the rotor current, which must be between 4 and 5 amp.

Short-circuit test

7. With the a.c. output terminals of the machine connected to the input terminals of the short-circuit load testing unit, the generator should be driven at 8,000 r.p.m. and the rotor current increased until the average line current is 30 amp. The rotor current should be between 9.7 and 10.7 amp. This condition should be maintained for 10 min.

Insulation resistance test

8. With the suppression capacitors disconnected at the brush gear and with the machine still warm, the insulation resistance, measured with a 250-volt insulation resistance tester between all live parts and the frame, should be not less than 0.05 megohm. After this test, re-connect the suppression capacitors.

RESTRICTED

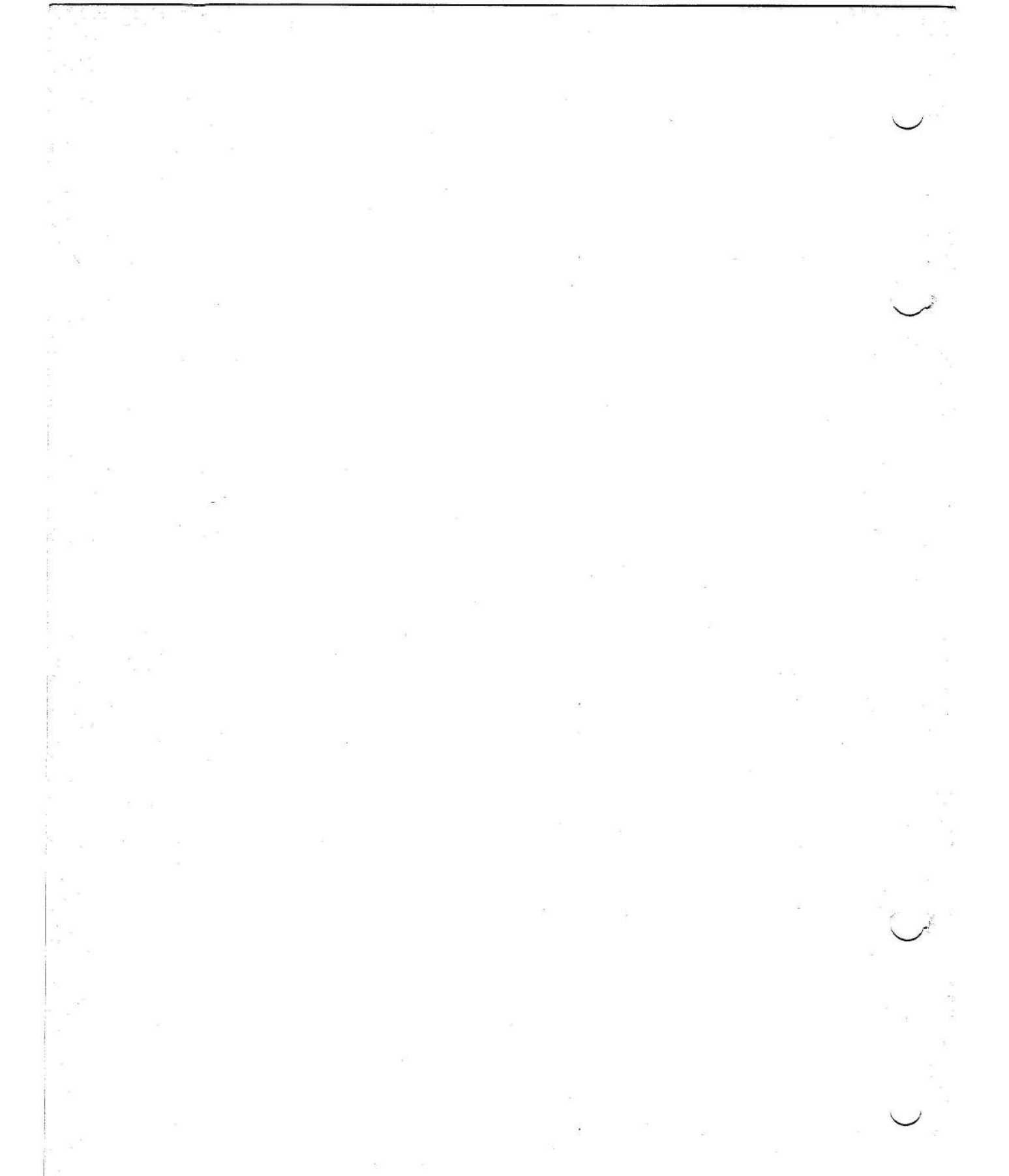

Appendix 1

GENERATOR, ROTAX, TYPE BA 1004

LEADING PARTICULARS

Generator, Type BA1004	Ref. No. 5UA/
<i>Output</i>	11 kVA at unity power factor
<i>Voltage</i>	208 volts a.c.
<i>Phase</i>	3 (star connected)
<i>Speed range</i>	6,500 to 10,000 r.p.m.
<i>A.C. output phase sequence</i>	Red, white, blue (terminal markings)
<i>Rotor supply</i>	28V (d.c.) via regulating resistor
<i>Rating</i>	Continuous
<i>Cooling</i>	Blast air (pressure equivalent to a head of 8 in. water gauge)
<i>Altitude</i>	50,000 ft. max.
<i>Temperature range</i>	-30 deg. C. to +50 deg. C.
<i>Rotation</i>	Either direction
<i>Phase rotation (when machine rotation is A/CW)</i>	Red, white, blue
<i>Brush grade</i>	KCEG.11
<i>Brush length—</i>					
<i>New</i>	0.800—0.820 in.
<i>Minimum permissible</i>	0.437 in. (over long edge)
<i>Brush spring pressure</i>	7–10 oz. (199–283 grams)
<i>Slip-ring diameter—</i>					
<i>New</i>	1.995 in.—2.005 in.
<i>Minimum permissible</i>	1.875 in.
<i>Overall dimension—</i>					
<i>Length (to flange face)</i>	8.890 in.
<i>Length (flange face to end of shaft)</i>	1.750 in.
<i>Body diameter</i>	6.531 in.
<i>Height (axis to top of terminal block)</i>	4.410 in.
<i>Weight</i>	29½ lb.

1. The BA1004 generator is identical with that described and illustrated in the main chapter. The inlet air supply is by direct blast at the slip-ring end of the machine, and the free air outlet is via ventilation slots

positioned around the main housing at the drive end.

2. The centre-line of the terminal block is radially disposed at an angle of 18 deg. from the dowel hole mentioned in para. 12. sub-para. (4) of the main chapter.

RESTRICTED

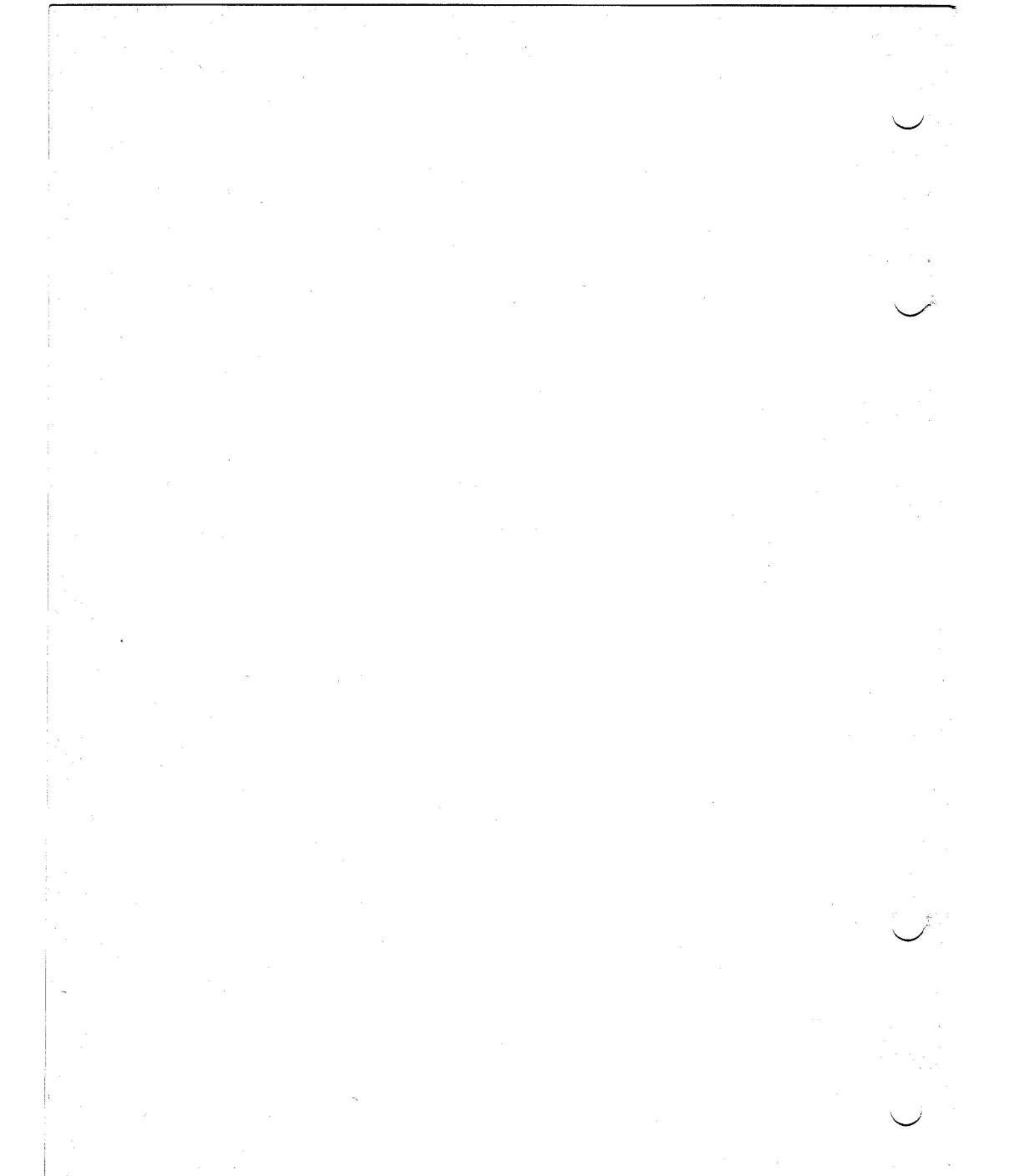

This file was downloaded
from the RTFM Library.

Link: www.scottbouch.com/rtfm

Please see site for usage terms,
and more aircraft documents.

