

Chapter 29

MOTOR-GENERATOR, TYPE B.507

LIST OF CONTENTS

	Para.		Para.
<i>Introduction</i>	1	<i>Cleaning</i>	
Description		<i>Magnetic inlet filter</i>	30
<i>Motor-generator assembly</i>	4	<i>Servo filter</i>	31
<i>Hydraulic motor</i>	5	<i>Renewal of 'O' seals</i>	32
<i>A.C. generator</i>	15	<i>Disassembling</i>	
Operation		<i>Motor-generator assembly</i>	33
<i>General</i>	20	<i>Hydraulic motor</i>	34
<i>Hydraulic motor</i>	21	<i>A.C. generator assembly</i>	35
<i>A.C. generator</i>	25	<i>Generator end casing assembly</i>	36
Servicing		<i>Generator casing assembly</i>	37
<i>General</i>	28	<i>Re-assembly</i>	38
<i>Bay servicing</i>	29		

LIST OF ILLUSTRATIONS

	Fig.		Fig.
<i>Motor-generator, Type B.507</i>	1	<i>Hydraulic circuit diagram</i>	4
<i>Motor generator assembly—cut-away</i>		<i>Electrical circuit diagram</i>	5
<i>view</i>	2	<i>Motor—exploded view</i>	6
<i>Torque motor—schematic diagram</i>	3	<i>A.C. generator—exploded view</i>	7

LIST OF APPENDICES

	App.
<i>Standard serviceability tests</i>	A

LEADING PARTICULARS

Motor-generator, type B507 (Pt. No. C/E2/01A) ...	Ref. No. 5UB/7518
<i>Output voltage</i>	103.6 ± 3% (mean)
<i>Rated output</i>	1 kW
<i>Output frequency</i>	2400 c/s ± 3%
<i>Load variations</i>	1W to 100W (approx.)
<i>Hydraulic motor supply pressure</i>	2665 to 3165 lb/in ² (gauge)
<i>Hydraulic fluid flow</i>	170 gall/hr (minimum)
<i>Hydraulic fluid (DTD.585)</i>	Oil, OM.15, Ref. No. 34B/9100572
Dimensions	
<i>Length overall</i>	17.5 in.
<i>Width (max.)</i>	6.6 in.
<i>Weight (dry)</i>	34 lb (approx.)
<i>Modification standard</i>	

The equipment described in this chapter embodies all relevant modifications up to and including BK.4663.

RESTRICTED

Introduction

1. The a.c. generator (fig. 1 and 2) described in this chapter provides a controlled $2.4\text{kc/s} \pm 3\%$ single phase electrical supply of 1 kW at $103.6 \pm 2.6\text{V}$ (mean); for the particular weapon installation with which it is used the output is measured at 115V r.m.s. The a.c. generator is driven by a balanced swash plate hydraulic motor, the two assemblies being bolted together to form a single unit.

2. The hydraulic motor is operated at a speed of 5143 rev/min by fluid supplied from aircraft engine driven pumps at a pressure between 2665 lb/in^2 and 3165 lb/in^2 (gauge) at a minimum flow of 170 gallons per hour. The motor is maintained at a constant speed by regulation of its fluid input through a servo operated throttle valve controlled by an electro magnetic torque motor (fig. 3) coupled to a frequency sensitive circuit connected to the a.c. generator output, and by variation of the swash plate angle. The fluid from the outlet of the hydraulic motor is caused to flow via a transfer tube through the stator windings, cooling and lubricating the

generator before it reaches the return end of the hydraulic circuits (fig. 4).

Note . . .

In earlier types it was the practice to drive the a.c. generator at 2400 rev/min through a step-up gear box, involving considerable complication of gear box design and lubrication, and consequently bulky and heavy assemblies. The introduction of a potted, multiple pole, laminated rotor in this a.c. generator and the use of DTD 585 hydraulic fluid as both lubricant and coolant eliminates the need for ram air cooling.

3. The a.c. generator functions in conjunction with the following complementary units:

(1) A capacitor and junction box containing resonating and compensating capacitors, a current transformer and the necessary plugs and sockets (A.P.4343B, Vol. 1, Book 2, Sect. 8, Chap. 42).

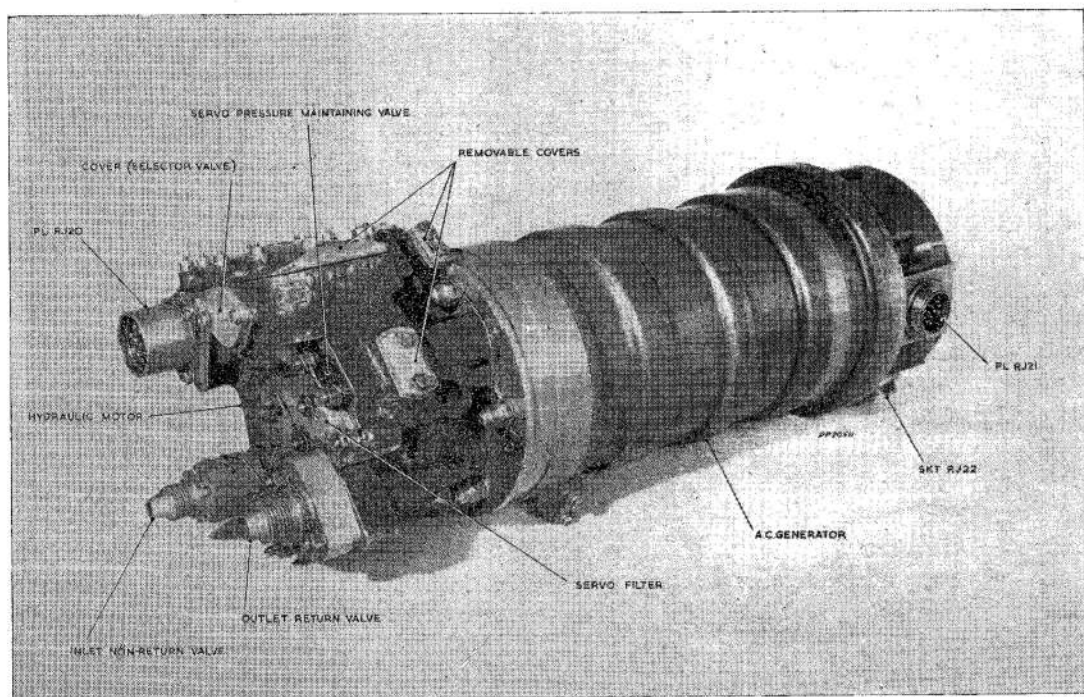

Fig. 1. Motor-generator, type B.507

RESTRICTED

(2) A control unit which provides frequency and voltage regulation and also protective circuits (A.P.4343B, Vol. 1, Book 2, Sect. 8, Chap. 41). The generator, junction box and control unit form the B507 generating system.

DESCRIPTION

Motor-generator assembly (fig. 1)

4. The a.c. generator is coupled to the hydraulic motor by means of a quill-shaft. The generator case is cast in aluminium alloy with an integral front bulkhead and is spigoted into the motor casing. The motor and generator are held together by studs and nuts to form the motor-generator assembly and the joint is made oil tight by an 'O' seal. They are tested as a complete unit together with the associated capacitor and junction box control unit (para. 3).

Hydraulic motor

5. The hydraulic motor is housed in an aluminium alloy casing assembly (fig. 2 and 5). In the same casing are housed the following ancillary items:

- (1) The non-return inlet valve.
- (2) The magnetic inlet filter, consist-

ing of a coarse cylindrical gauze surrounding a non-ferrous spigot, contains a small rod magnet to attract ferrous metallic particles out of the hydraulic fluid stream; any such particle will adhere to circlips on the periphery of the spigot, whence they can easily be removed during servicing.

(3) The servo-operated throttle system consisting of a servo-pressure maintaining valve, a servo filter, a torque motor, a selector valve, a servo piston and a throttle valve.

(4) A dash pot assembly.

(5) A non-return outlet.

6. The fluid under pressure is fed to the motor casing via the non-return inlet valve and the magnetic inlet filter prior to entering the rotary throttle valve which regulates the fluid inlet pressure to the motor. Removable covers seal certain cross drillings and enable the motor housing to be cleaned and inspected during manufacture and reconditioning.

7. The electro-magnetic torque motor is not sufficiently powerful to operate the throttle valve directly; therefore the torque

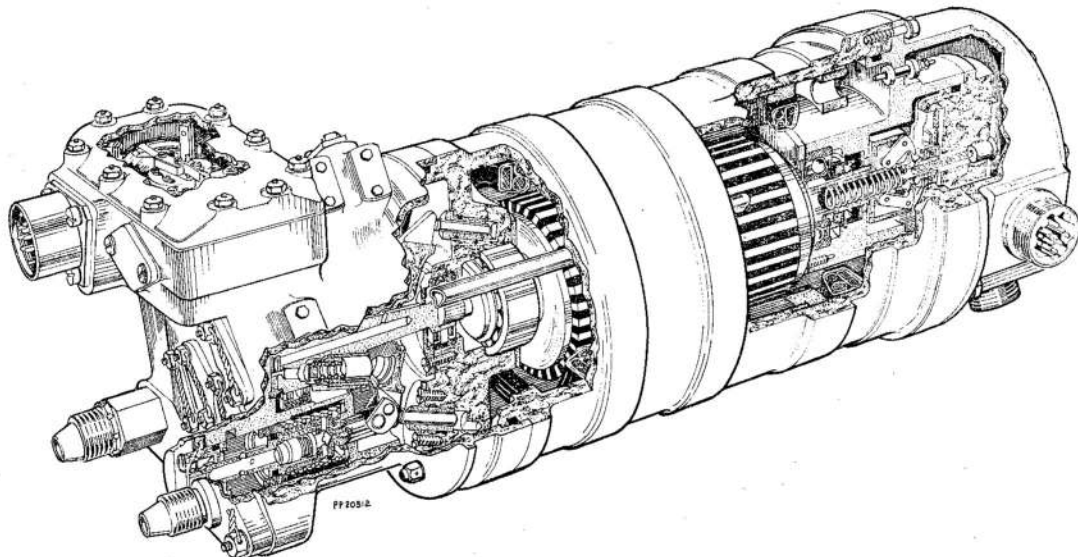

Fig. 2. Motor generator assembly—cut-away view

RESTRICTED

motor is used to operate a selector valve which admits hydraulic fluid via the motor return line to one or other of the faces of the servo piston to which the operating lever of the throttle valve is attached. Movement of the torque motor armature thus causes the servo piston to open or close the throttle valve. A leaf spring couples the torque motor armature to the throttle lever so that movement of the throttle lever in either direction produces a reverse torque on the torque motor armature, thus providing a mechanical feedback link. The armature tends to return to its central position until its torque balances the leaf spring torque: the throttle valve is then held at the required setting by the selector valve.

8. The electro-magnetic torque-motor consists of two soft-iron cores containing two permanent magnets and a soft-iron armature supported on ball bearings in each of two end plates. Each core carries two windings connected in such a manner that when they are energized the resulting magneto-motive forces set up fluxes which either aid or oppose the fluxes derived from the two permanent magnets causing the armature to rotate on its axis through a maximum of 7.5° approximately in either direction (a total of 15°) from its initial position of equilibrium. The direction and angle of rotation, before equilibrium is again restored, are dependent upon the sign and magnitude of the current passing through the windings.

9. An arc shaped wire-wound potentiometer is attached to the throttle assembly and its wiper is secured to the throttle valve operating lever; this potentiometer is connected to a frequency feed-back circuit contained in the controller (para. 3).

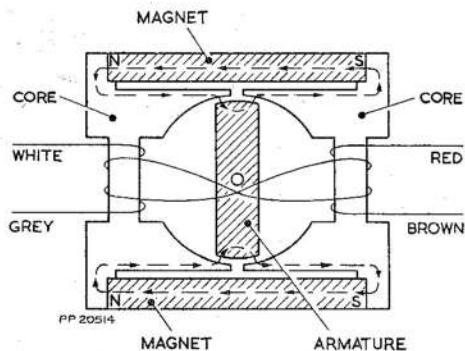

Fig. 3. Torque motor—schematic diagram

Any error in the output frequency of the a.c. generator is detected by the controller, which then provides two control currents for the two circuits to the electro-magnetic torque-motor for operation of the selector valve.

10. The throttle valve consists of a rotary valve within a fixed cylindrical sleeve, the contours of the valve being such as to increase or decrease the effective area of the two ports in the upper part of the sleeve as the valve is rotated.

11. The motor assembly consists of a rotor having five outwardly inclined cylinders around its axis, and an inclined swash plate housed in the motor casing; each cylinder is sleeved and contains a piston and a compression spring. The spherical outer end of each piston is fitted with a pad which slides on the operating face of the swash plate. As the rotor revolves, a port at the inner end of each cylinder aligns in turn with an arc-shaped inlet port and a similarly shaped output port. These two ports are machined in a flat circular plate, which is secured in the motor housing; this plate also acts as an end thrust bearing for the rotor. The rotor is supported by a large roller bearing around its periphery and a smaller roller bearing on its drive shaft end, this latter bearing which is housed in the front bulk-head of the a.c. generator casting supports the coupling between the motor and the generator.

12. The swash plate pivots on two integral trunnions which are supported in bearing blocks, fitted to recesses in the motor casing. The change of swash plate angle is effected by two actuator pistons, diametrically opposed across the trunnion centre line and operating on the back of the swash plate. In effect the two pistons receive and absorb the pressure drop across the throttle valve: i.e. one actuator piston is linked hydraulically via a transfer tube to the input side of the throttle valve and the other actuator piston is similarly linked to the motor inlet side of the throttle valve.

13. A spring in the dash pot assembly [para. 5(4)], linked to the yoke of the swash plate, ensures that the swash plate angle changes only when the fluid pressure across the throttle exceeds 600 lb/in^2 . A spring loaded bleed valve incorporated within the dash pot piston bleeds the hyd-

raulic fluid back into the circulating system, thus damping the reduction in swash plate angle while permitting rapid increase of angle as required. The maximum and minimum angular movements of the swash plate are controlled by adjusting shims on both sides of the dash pot housing flange. Decrease in the swash plate angle beyond the permissible limit is prevented by a stop plate secured to the dash pot piston spindle; a spigot formed inside the cover plate of the dash pot housing further limits increase of the swash plate angle.

14. A drilling connects the motor outlet port to a chamber containing the spring-loaded servo pressure maintaining valve; fluid passing this valve is fed through the sintered bronze type servo filter and the selector valve to operate the servo piston before passing through the non-return outlet valve on the motor casing. The main function of the servo pressure maintaining valve is to ensure that the servo pressure is maintained at all times at 50 lb/in² above the return line pressure.

A.C. generator

15. The a.c. generator is of the polar inductor type, and has a 28-pole rotor revolving within a stator contained in a machined aluminium-alloy casing. A bulkhead integral with the generator casing houses a roller bearing at the motor end of the generator. The bulkhead is fitted with five studs which secure the generator casing to the motor casing. The opposite end of the generator casing is bolted to a spigoted end casing which houses the ball bearing supporting the other end of the rotor shaft and contains the carrier and striker assembly (para. 19).

16. The stator assembly contains four major poles with field windings. Each major pole is sub-divided into two minor poles of like polarity. Each of its four output coils encloses one pair of unlike minor poles. Each pole of the stator has six teeth, thus making a total of twenty four teeth. The rotor having twenty eight poles, twenty eight cycles are produced per revolution of the rotor; therefore the output frequency of 2400c/s, is achieved at 5143 rev/min (para. 26).

17. The rotor assembly consists of a stack of 28-pole iron laminations assembled around a sleeve mounted on a tubular steel rotor-shaft. The stack is clamped between two clamping rings by a ring nut screwed on to the motor end of the rotor shaft and retained against an integral collar on the opposite end of the same shaft. The end float of the motor is limited via the quill shaft by a locking screw assembly (fig. 2 and 6).

18. The rotor is potted in epoxy resin which is ground flush with the pole faces to for a smooth cylinder and so reduce the drag of the rotor to a minimum whilst the hydraulic fluid is circulated through the generator coil for cooling purposes.

19. The carrier and striker assembly (fig. 2 and 6) is a centrifugal mechanism, and is screwed to the rotor shaft. The striker tube has one end inserted in the carrier, and the other end held in position by its collar against the pressure of a spring kept under compression by four pivoted L-shaped balance weights between the neck of the striker and a plug at the rotor end of the carrier. When the rotor speed exceeds a nominal rev/min the balance weights fly out and depress the striker against the spring. The striker, when depressed, slides on a guide rod and actuates a microswitch housed in the end casing unit of the a.c. generator. Three leads connect the microswitch to PL R.J 21 (fig. 5). The function of the microswitch is to prevent the generator from operating below the nominal speed and is associated with the protective circuits in the controller. Further information on the protective circuits is given in A.P.4343B, Vol. 1, Book 2, Sect. 8, Chap. 41.

OPERATION

General

20. Hydraulic fluid DTD 585 is used for driving, cooling and lubricating the a.c. motor-generator.

Hydraulic motor

21. A schematic diagram showing the operation of the hydraulic motor is given in fig. 4, to which the description contained in para. 22 to 27 refers by means of corresponding numbers in parentheses.

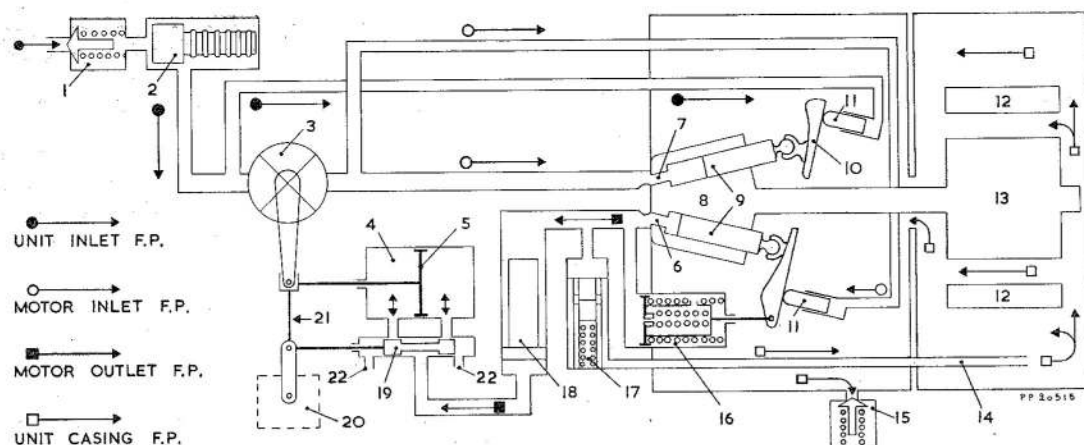

NOTE. THE MOTOR OUTLET FLUID PRESSURE IS 50 lb/in² ABOVE UNIT CASING PRESSURE

- 1 INLET NON-RETURN VALVE
- 2 MAGNETIC INLET FILTER
- 3 THROTTLE VALVE
- 4 SERVO CYLINDER
- 5 SERVO PISTON
- 6 MOTOR OUTLET PORT
- 7 MOTOR INLET PORT
- 8 MOTOR ROTOR
- 9 PISTONS
- 10 SWASH PLATE
- 11 SWASH PLATE ACTUATOR PISTONS

- 12 GENERATOR FIELD AND OUTPUT WINDINGS
- 13 GENERATOR ROTOR
- 14 FLUID TRANSFER TUBE
- 15 OUTLET NON-RETURN VALVE
- 16 DASH POT
- 17 SERVO PRESSURE-MAINTAINING VALVE
- 18 SERVO FILTER
- 19 SELECTOR VALVE
- 20 ELECTRO-MAGNETIC TORQUE MOTOR
- 21 LEAF SPRING
- 22 DRAIN FROM SERVO CYLINDER

Fig. 4. Hydraulic circuit diagram

22. Hydraulic fluid at a pressure of between 2665 and 3165 lb/in² (gauge) passes through the non-return valve (1) and magnetic inlet filter (2) to the throttle valve (3) which controls the fluid pressure to the motor rotor (8). From the throttle fluid at an approximate pressure of between 1200 and 2800 lb/in², depending upon the throttle opening, is fed to the motor. The motor inlet port (7) allows fluid to enter those cylinders of the rotor which are aligned with the port, causing the pistons (9) to move outwards and the sliding pads on the spherical ends of the pistons to press against the swash plate (10); the rotor, therefore, revolves and attains a speed of 5143 rev/min. A motor outlet port (6) is provided so that the pistons are able to expel fluid into the hydraulic system return line.

23. The fluid expelled through the motor output port flows through a transfer tube (14) via the servo pressure maintaining non-return valve (17) and returns through generator field windings to the outlet non-

return valve (15). The pressure maintaining valve ensures that the fluid pressure for the servo system is available at all times by maintaining a pressure differential of approximately 50 lb/in² between the motor outlet and the return line pressure. The unit outlet non-return valve opens when the pressure in the motor return line is more than the pressure in the main return line of the aircraft's hydraulic system.

24. The electro-magnetic torque motor (20) functions on information received from the frequency governing circuits in the controller and in turn operates the selector valve (19) which admits fluid, tapped from the motor return line, to one side or the other of the servo piston (5) to which the throttle operating lever is attached (see para. 7). If, with normal swash plate angle the throttle valve opening were small, considerable energy loss with consequent heating, would take place across the throttle valve; to avoid this and to maintain the throttle valve opening as near optimum as possible the angular set-

RESTRICTED

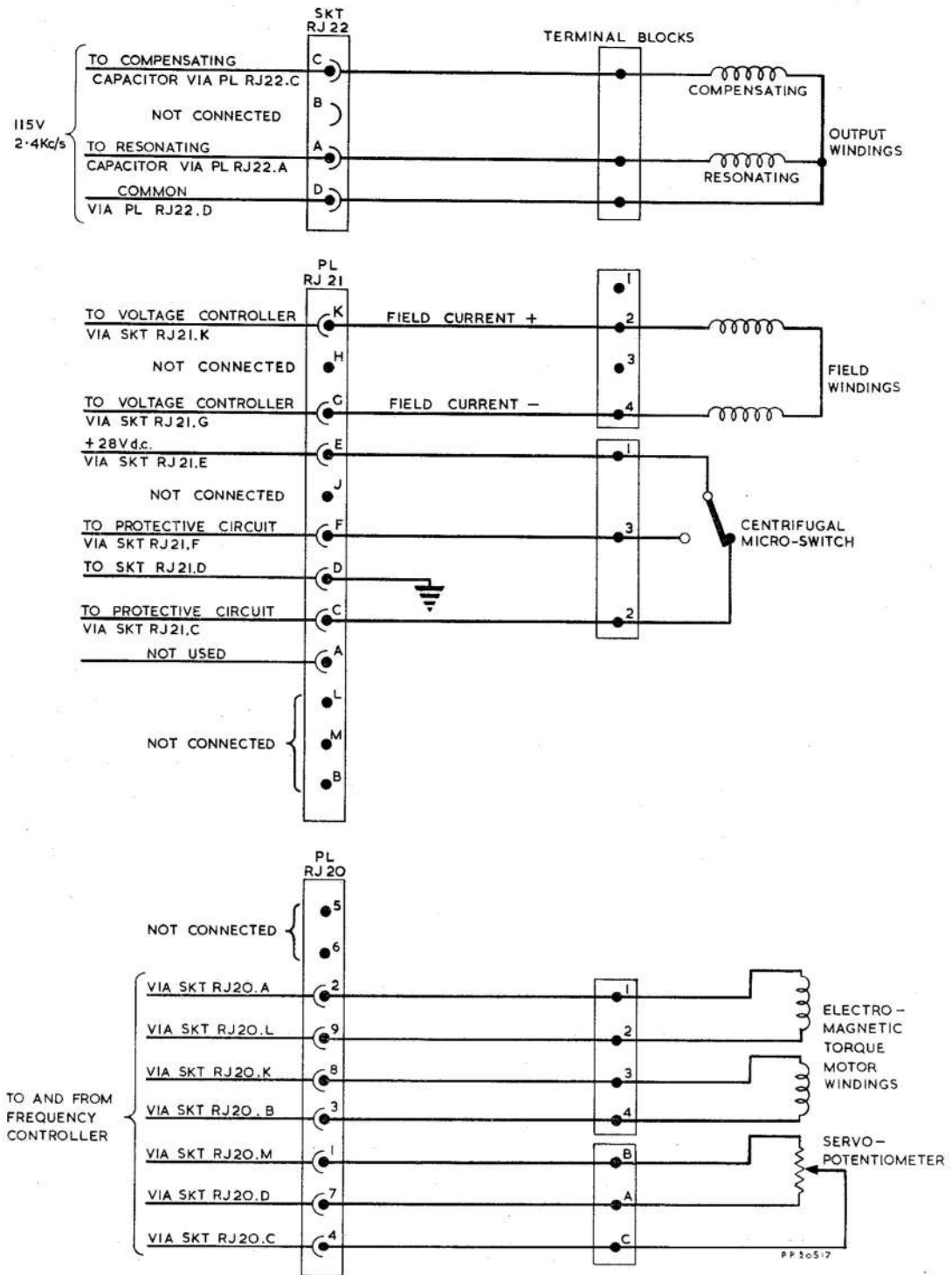

NOTE. ALL INPUTS AND OUTPUTS OF THE GENERATOR ARE CONNECTED VIA CAPACITOR AND JUNCTION BOX TYPE COOE20020A

Fig. 5. Electrical circuit diagram

RESTRICTED

ting of the swash plate is varied by two actuator pistons and the swash plate control spring, located in the dash pot assembly (16). If the pressure drop across the throttle valve is high, the throttle valve is closed to decrease the motor speed and the actuator pistons move to reduce the swash plate angle; this reduces the mechanical advantage of the motor, which will therefore lose speed and enable the throttle valve opening to be increased. When the motor starts, the throttle lever is in its mid position and the swash plate control spring of the dash pot assembly sets the swash plate at its maximum angle, thus the normal running speed of the motor is rapidly attained.

A.C. generator

25. The a.c. generator being of the polar inductor type (para. 15) it has the advantage of having no rotor windings and therefore no slip rings. The generator has a high internal impedance, which necessitates the inclusion of a capacitance (located in the capacitor and junction box, para. 3) in series with the load in the manner customary with inductor generators. The value of the capacitance is chosen to resonate with the generator windings at approximately the output frequency of 2400c/s, because a series resonant circuit has a low impedance at the resonant frequency. At frequencies other than resonant frequency, the impedance of this resonant circuit increases, with the result that when non-linear load are applied, the harmonic content of the output waveform is increased. Hence to filter the harmonics in the a.c. generator output waveform, a compensating winding, separate from the output winding but wound in the same sense is introduced and is connected to a capacitance in the capacitor and junction box assembly.

26. The magnetic flux due to the field windings also passes through the output windings, and the flux linkage between the field and the output windings is reversed every 6.43 degrees rotation of the rotor, 28 complete cycles occurring per revolution. The output frequency of 2400c/s is obtained at a rotor speed of 5143 rev/min.

27. The field windings consist of four coils connected in series. These coils are normally energized by the output of the voltage regulation circuits of the controller, the input of which is obtained from the

generator output (fig. 7). During operation, the field current is varied as necessary to maintain the desired output voltage. The residual magnetism in the stator poles is insufficient to produce an output in the field windings; for starting purposes, therefore, the windings are initially energized from the aircraft electrical system via a diode rectifier; when the generator voltage is sufficient this rectifier blocks the output voltage from the controller unit.

SERVICING

General

28. The following security checks should be made during routine servicing in the aircraft:

- (1) Examine all securing bolts, nuts and screws for tightness and ensure that the motor-generator assembly is securely attached to its housing in the aircraft.
- (2) Check the hydraulic connections and electrical connections for security.
- (3) Examine the assembly for hydraulic fluid leakage.

Bay servicing

29. At the periods stated in the relevant Aircraft Servicing Schedule the motor generator should be removed from the aircraft, drained of hydraulic fluid, and placed on a pedestal mounted on a work bench provided with a drip tray in a dust-free area. The following servicing operations should be effected at the intervals detailed in the Bay Servicing Schedule.

Cleaning

30. *Magnetic inlet filter.*—Clean and replace this filter as follows:

- (1) Cut the locking wire and remove the two nuts and washers that secure the inlet filter unit to the hydraulic motor casing.
- (2) Raise the end of the motor generator so that the inlet filter can be withdrawn in a downward direction, thus preventing residue entering the motor housing through the filter output port.
- (3) Withdraw the filter assembly from the unit and wash the gauze with

trichlorethylene or carbon tetrachloride (C.T.C.); dry the gauze with a clean dry air blast.

(4) Carefully remove any deposit from the circlips of the magnet case, wash the magnet case with C.T.C. or trichlorethylene and dry it with a clean dry air blast.

(5) Fit a new 'O' seal.

(6) Assemble the filter unit to the hydraulic motor casing and secure it with the washers and retaining nuts. Lock the nuts with 22 sw.g. wire (DTD 189).

31. Servo filter.—Clean and replace this filter as follows:

(1) Cut the locking wire, unscrew the two nuts and remove the washers and the cap.

(2) Withdraw the filter in a downward direction.

(3) Blow with a clean dry air blast in the reverse direction of the flow through the filter.

(4) Replace the filter, bush end first, in the motor casing.

(5) Renew the 'O' seal.

(6) Lock the cap to the motor casing and secure it with washers and nuts. Lock the nuts with 22 s.w.g. wire (DTD 189).

Renewal of 'O' seals

32. 'O' seals should normally be renewed after dismantling operations and whenever signs of oil leakage are observed.

Dismantling

33. Motor generator assembly. — The hydraulic motor may be separated from the a.c. generator as follows:

(1) Cut the locking wire and remove the five dome nuts [using the special ring spanner (Ref. No.)] securing the motor casing to the generator casing and taking care not to

damage the bonded seals under the dome nuts.

(2) Carefully separate the motor assembly from the generator assembly, keeping the assemblies in line and the generator assembly supported on blocks until the quill shaft and fluid transfer tube are free.

34. Hydraulic motor. — Dismantle the motor assembly as follows:

(1) Remove the split pin and washer from the swash plate yoke linking pin and remove the linking pin.

(2) Remove the tab washers and unscrew the two retaining bolts securing the trunnion blocks in their housings, then tilt the motor casing and remove the swash plate together with the trunnion blocks and the hydraulic motor.

(3) Place the swash plate with the motor complete with pistons in a dust proof bag.

(4) Gently pull out from the motor casing the fluid transfer tubes for the two actuator pistons.

(5) Unscrew the four countersunk retaining screws and remove the segmented bearing retaining and segmented shims, then remove the inner roller bearing from the motor.

(6) Remove the eight nuts and spring washers which secure the cover plate over the throttle assembly, then remove the cover plate and gasket.

(7) Unscrew the two cheesehead screws, washers and spring washers and remove the selector valve cover and 'O' seal.

(8) Unscrew the lock nut on the selector valve adjusting screw and unscrew the selector valve.

(9) Slacken the pinching bolt on the torque motor arm and remove the leaf spring assembly complete with the spring retainer. Then gently remove

the selector valve.

(10) Unscrew the four retaining screws and gently remove the torque motor assembly.

Note . . .

Connecting leads to and from the torque motor and the potentiometer on the throttle are looped to facilitate removal of the components from their housings.

(11) Unscrew the two retaining screws from the selector valve sleeve and draw the sleeve out with an extractor screw.

(12) Remove the two retaining screws securing the potentiometer wiper arm on the throttle link assembly and swing out the wiper arm; remove the split pin on the servo piston connecting link and remove the link pin. Unsolder the potentiometer winding connections.

(13) Remove the circlip and fit two extractor screws on the throttle sleeve and gently remove the sleeve and the throttle valve complete with the potentiometer assembly.

(14) Dismantle the throttle as follows:—

(a) Remove the four screws which secure the throttle link assembly.

(b) Remove the mounting lever pad by driving out the retaining pin.

(c) Remove the two screws which secure the potentiometer winding assembly.

(d) Remove the two screws which secure the potentiometer bus bar.

(e) Remove the two screws which secure the support.

(f) Press the throttle and bearing from the sleeve.

(g) Remove the circlip which retains the smaller bearing and remove the bearing with the special extractor (Ref. No.).

(h) Hold the throttle with the special clamping fixture (Ref. No.) and remove the retaining

nut and washer from the larger bearing. Remove the bearing with the extractor.

(j) Remove the 'O' seal from the internal groove in the sleeve.

(15) Unscrew the three retaining screws and remove the pressure plug and 'O' seal.

(16) Cut the locking wire and remove the two nuts, and with an extractor screw, draw the servo pressure-maintaining valve housing complete with the valve, shims, spring, retaining plate and circlip from the motor casing.

(17) Cut the locking wire and unscrew the non-return inlet valve assembly from the motor casing and examine the Dowty washer.

(18) Cut the locking wire and remove the two nuts and washers securing the non-return outlet valve assembly to the motor casing. Remove the 'O' seal.

(19) Unscrew the two countersunk securing screws from each actuator piston sleeve flange and pull out the two actuator pistons with sleeves complete from the motor end bulkhead of the generator casing.

(20) Unscrew the four countersunk screws securing the backing ring for the hydraulic motor drive and roller bearing from the motor end bulkhead of the generator casing. Remove the roller bearings.

35. A.C. generator assembly.—The a.c. generator assembly is divided into two main sub-assemblies, the end casing assembly and the generator casing assembly; these two sub-assemblies may be separated as follows:

(1) Using the special clamping fixture (Ref. No.), unscrew the six securing bolts, remove the spring washers and plain washers.

(2) Separate the end casing assembly, together with the motor assembly from the generator casing assembly.

36. Generator end casing assembly.—Dismantle the generator end casing assembly as follows:

- (1) Remove six securing screws, spring washers and plain washers.
- (2) Remove the end casing cover plate.
- (3) Unsolder three leads, remove six screws and spring washers; remove the microswitch assembly, 'O' seal and leads.
- (4) Remove the grub screw locking the carrier and striker assembly to the rotor shaft. Using the special stub-shaft (Ref. No.) to hold the rotor, unscrew the carrier and striker assembly from the rotor shaft by means of the special key spanner (Ref. No.).
- (5) Unscrew the three retaining bolts; remove the tab washers and the ball bearing retaining plate. Press out the rotor shaft from the end casing. Unscrew the ring nut, using the special peg spanner (Ref. No.); remove the tab washer and, using the special bearing extractor (Ref. No.) remove the ball bearing.
- (6) Unlock the tab washer and using the special peg spanner (Ref. No.) unscrew the ring nut retaining the rotor shaft roller bearing located at the motor end.
- (7) Using the special torque spanner (Ref. No.) rotate the rotor nut, which, acting as an extractor removes the inner portion of the rotor assembly roller bearing. Remove the locking screw assembly.

Note . . .

No attempt should be made to remove the potted rotor from its shaft.

- (8) Remove the circlip, lip seal and backing ring from the end casing assembly.

37. Generator casing assembly.—Dismantle the generator casing assembly as follows:

- (1) Unsolder the output winding leads from the connections on the connector plate assembly.
- (2) Remove the circlip retaining the connector plate assembly and remove the connector plate.
- (3) Using the special torque spanner (Ref. No.) release and remove the ring nut, thus facilitating removal of the stator assembly; remove the stator.
- (4) Remove the plate retaining the outer race of the generator shaft bearing by unscrewing three screws.
- (5) Using the bearing extractor (Ref. No.) remove the outer race of the roller bearing from the generator casing.
- (6) Remove the plate retaining the motor rotor roller bearing plate by unscrewing three screws.
- (7) Remove the motor rotor roller bearing from the generator casing.

Re-assembly

38. The following general procedure must be adopted when re-assembling the motor generator:

- (1) Re-solder any disconnected electrical leads to their correct terminals, using BS441 cored solder DTD 599; ensure that external portions of terminals and holes are free from dirt and that there are no dry joints.
- (2) Degrease all valve assemblies, plungers, sleeves, pistons and bearings thoroughly with tetrachloride (C.T.C.) or trichlorethylene and dry them with a clean dry air blast; re-lubricate the parts with DTD 585 only before assembling them.
- (3) Renew all 'O' seals that have been disturbed, renew gaskets, lip seals and bonded seals as necessary.
- (4) Lock all components where applicable with 22 s.w.g. wire (DTD 189).

(5) Before re-assembling ensure that all components and drilled channels are free from any foreign matter and dust with a blast of clean dry air.

39. To re-assemble or renew the components removed from the motor casing and the generator casing, follow the procedures set out in para. 30 to para. 37 and their relevant sub-para. in reverse order with the following provisions:

(1) The locking screw assembly contained in the rotor assembly must be adjusted by the use of the special screwdriver (Ref. No.).

(2) A protective sleeve must be used on the rotor shaft when it is being assembled into the end casing assembly to protect the associated lip seal.

(3) When re-assembling the bearings the appropriate bearing inserters must be used where such are applicable.

(4) When re-assembling the stator assembly the retaining ring nut must be assembled wet with DHP. 274 Type B varnish to ensure adequate locking and tightened to a torque loading of 900/950 lb/in.

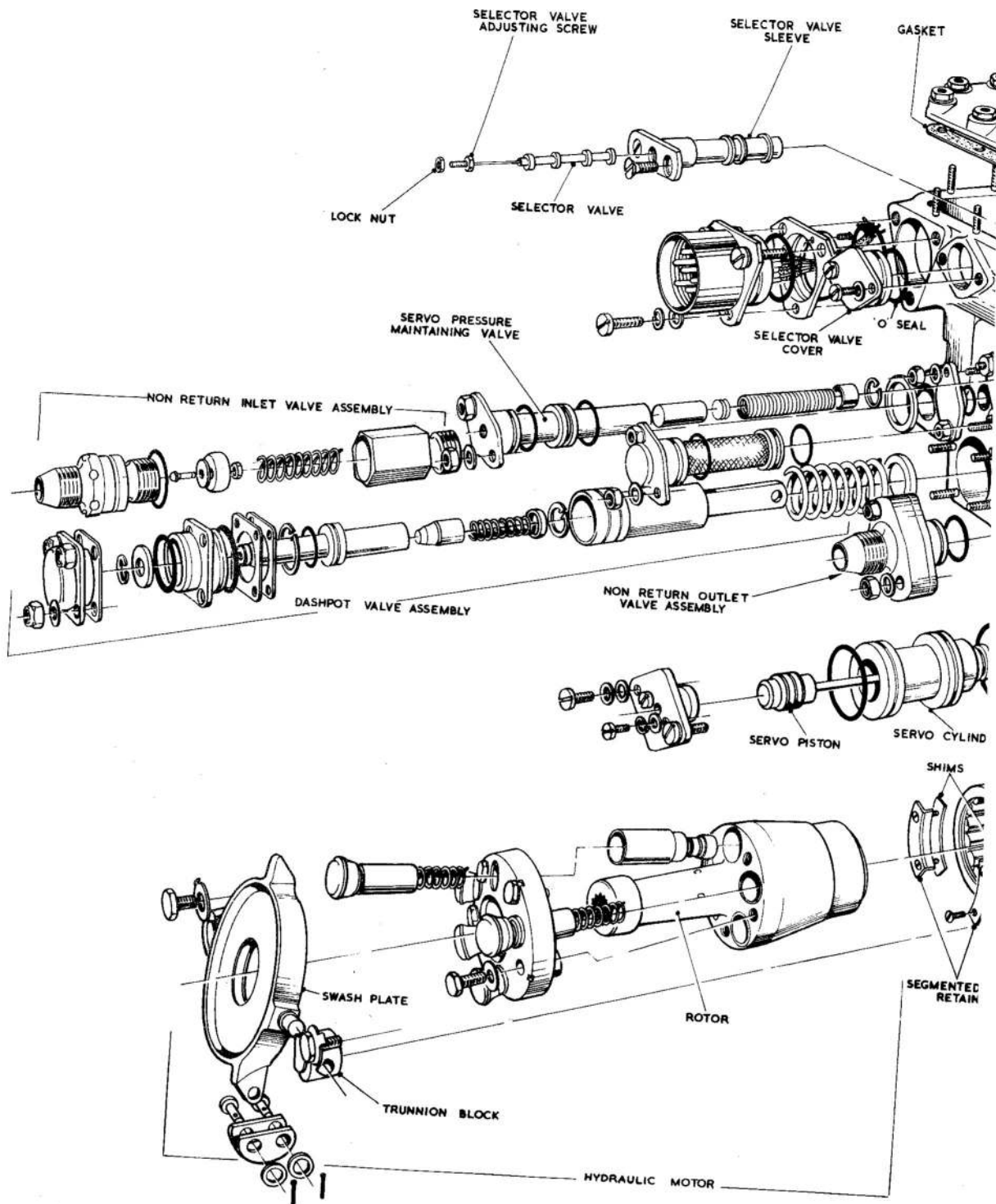
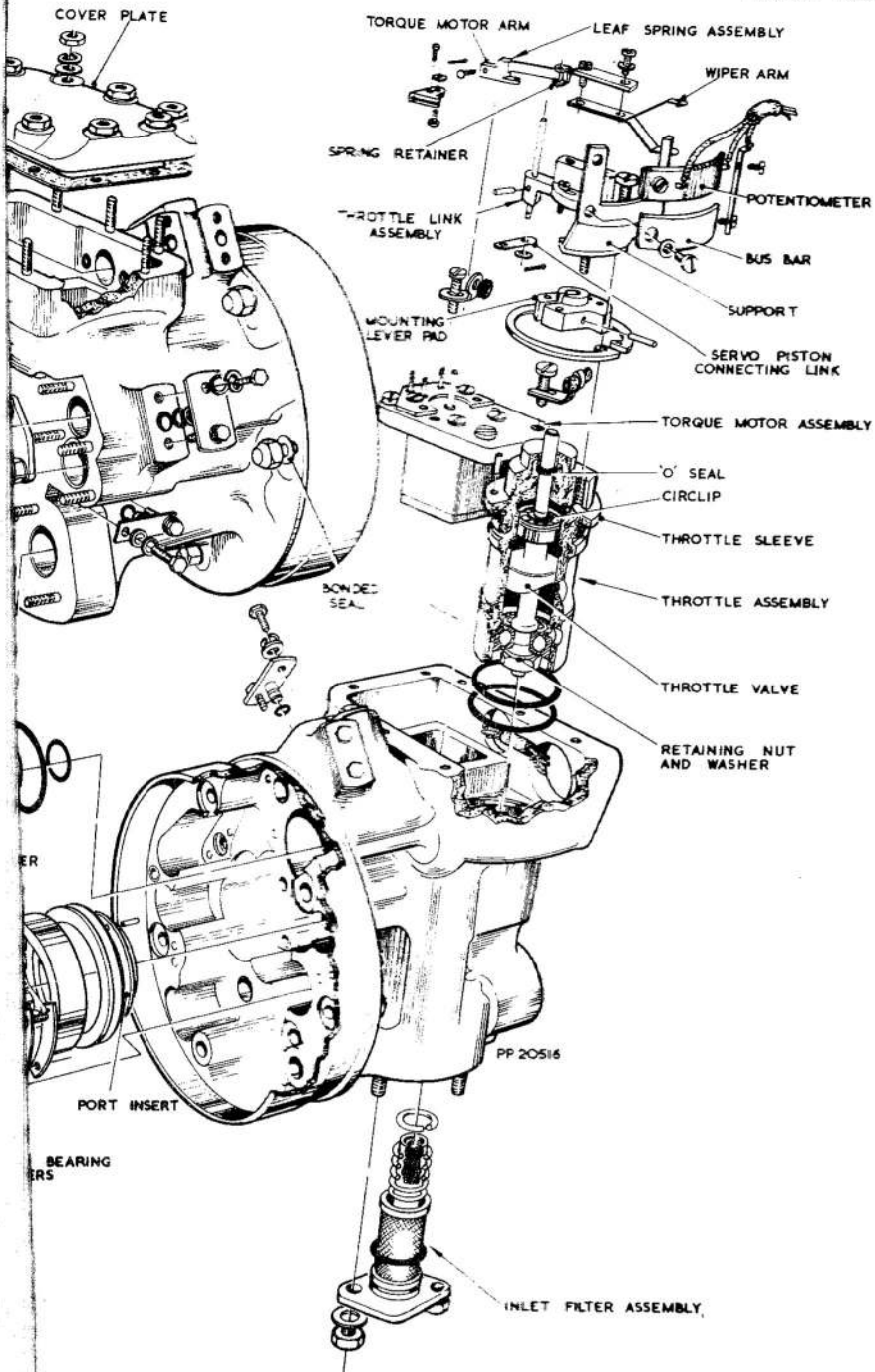

Fig. 6

A.P. 4343A. Vol. 1, Sect. 2, Chap. 29
A.L. 139 Feb. 64



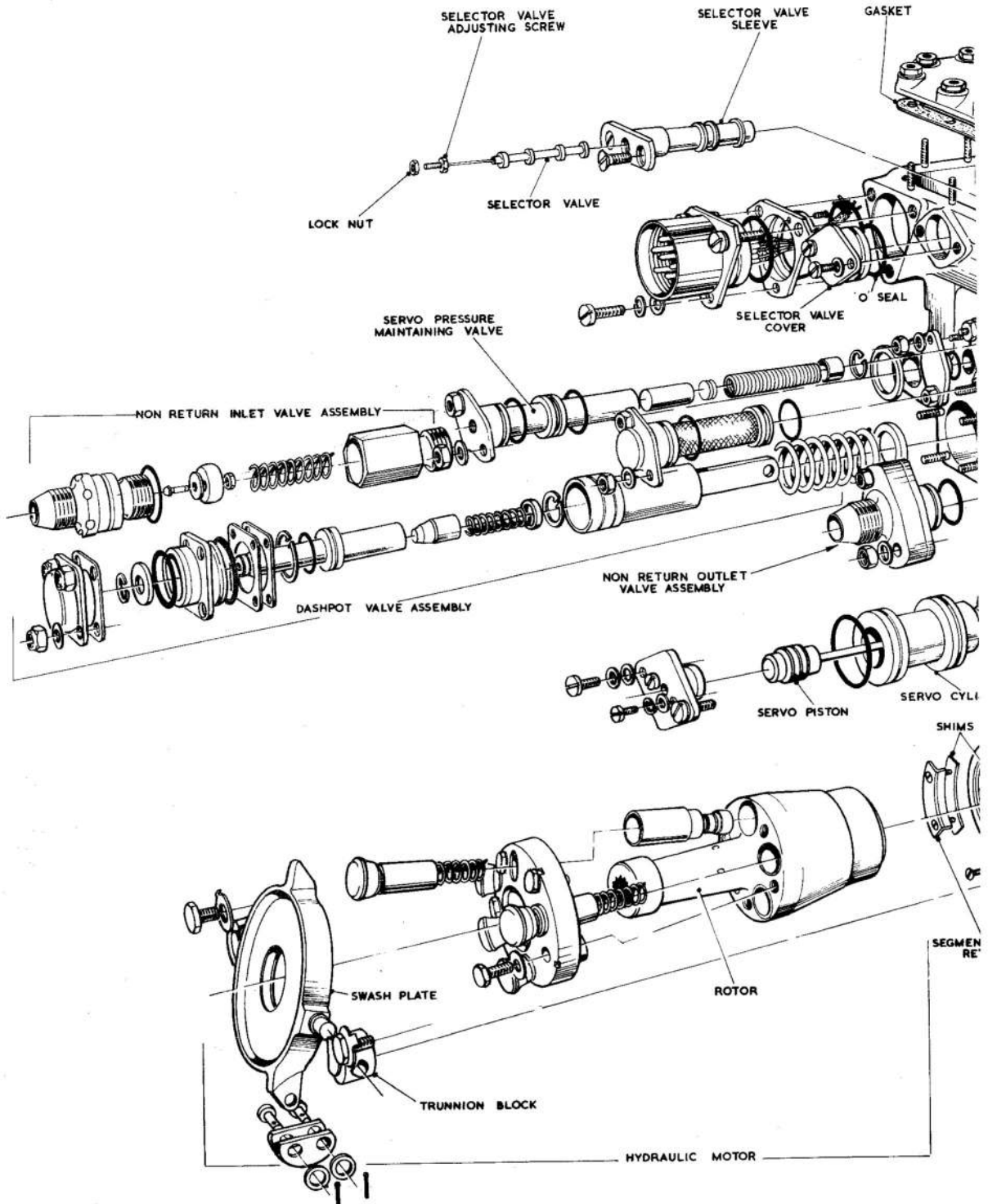

Fig. 6

Motor- exploded view
RESTRICTED

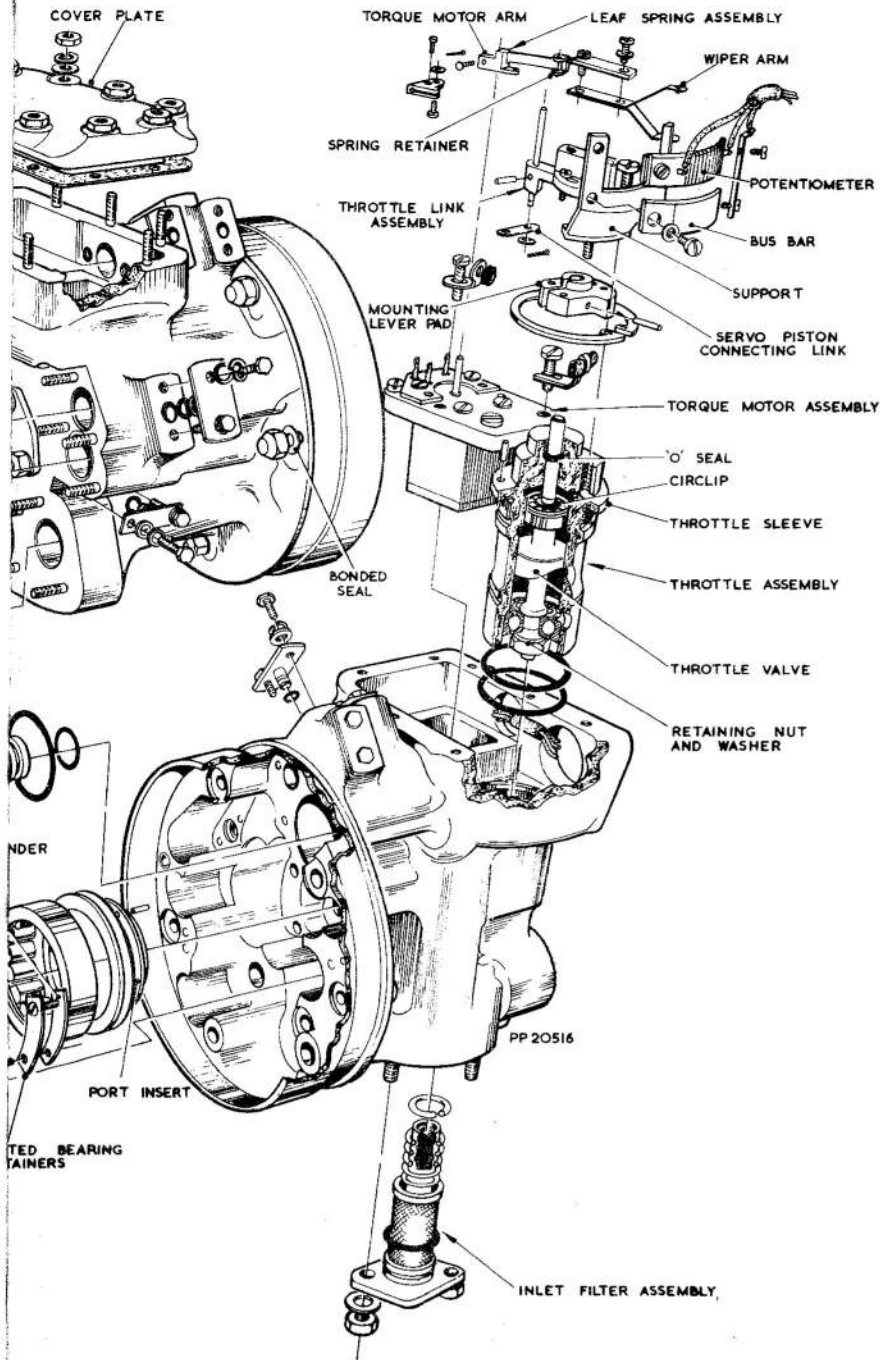

Fig. 6

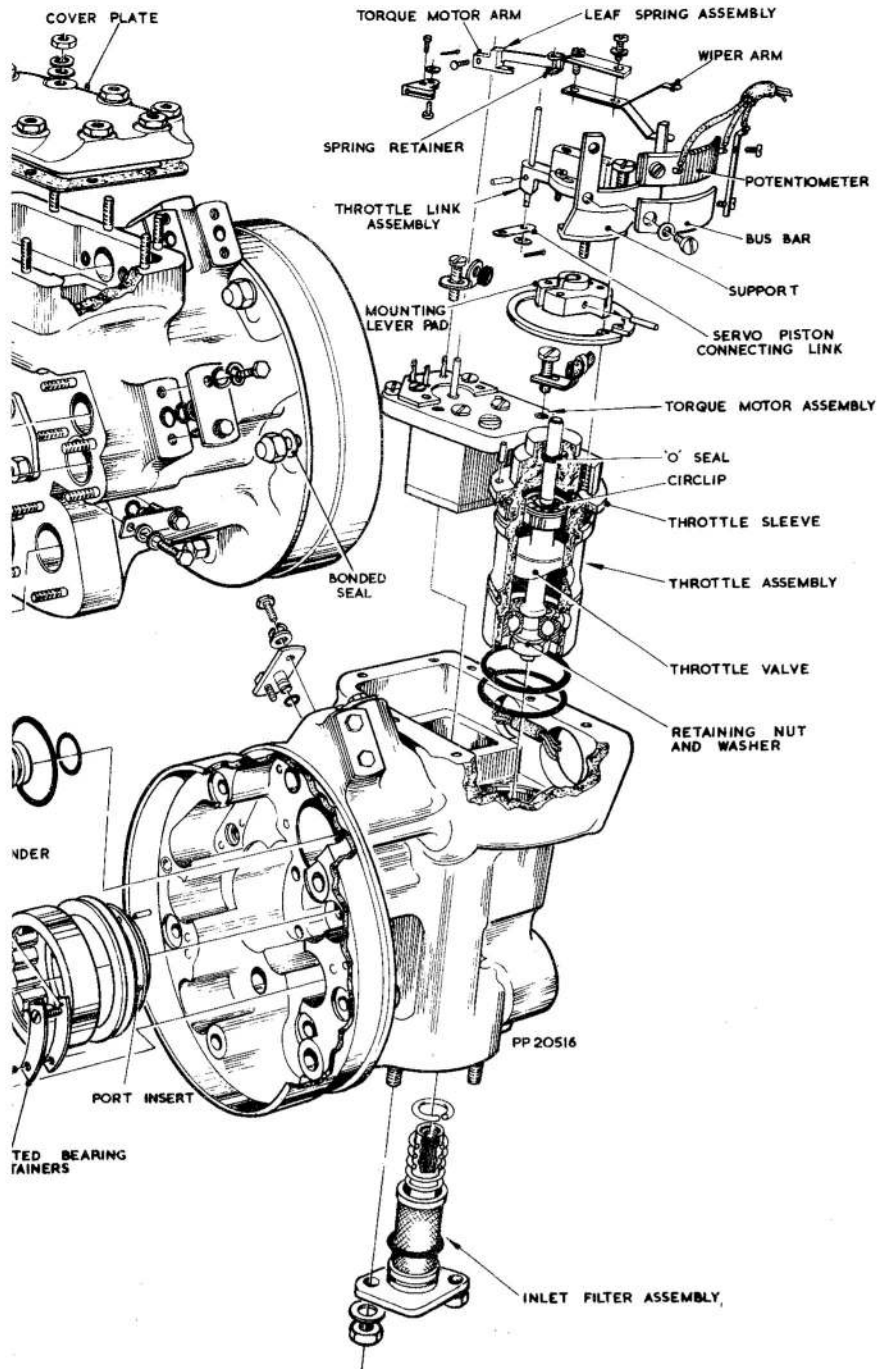

Fig. 6

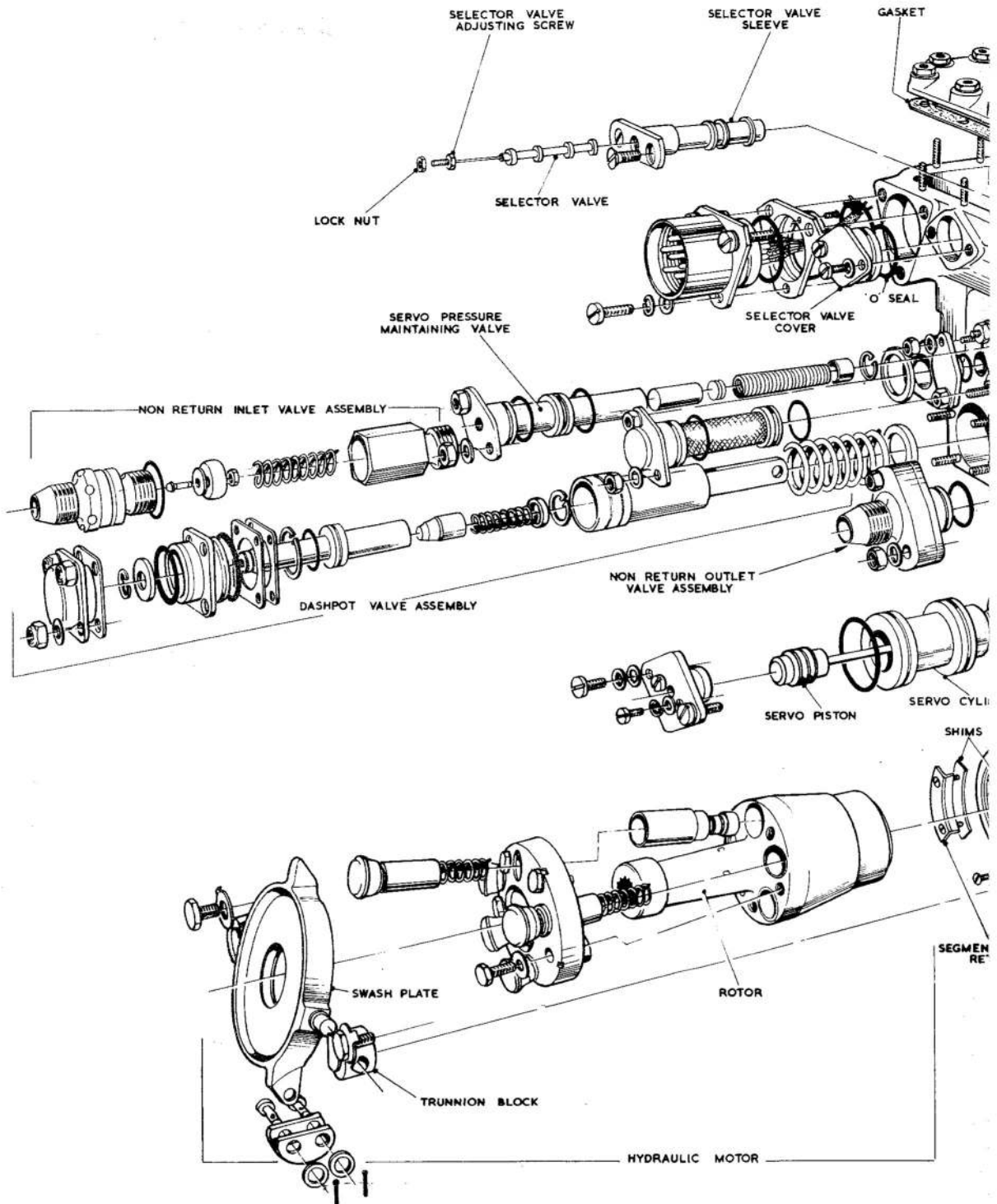

Fig. 6

Motor- exploded view
RESTRICTED

Appendix A

STANDARD SERVICEABILITY TESTS

LIST OF CONTENTS

	<i>Para.</i>		<i>Para.</i>
<i>Introduction</i>	1	<i>Test interconnections</i>	24
First line testing *		<i>Test procedure</i>	
<i>Test equipment required</i>	2	<i>Test 1</i>	25
<i>Preparation for testing</i>	3	<i>Test 2</i>	26
<i>A.C. generator output tests</i>	4	<i>Test 3</i>	27
<i>Conclusion of testing</i>	5	<i>Test 4</i>	28
Second line testing		<i>Test 5</i>	29
<i>General</i>	7	<i>Test 6 (crash start)</i>	30
<i>Hydraulic supplies</i>	13	<i>Conclusion of testing</i>	31
<i>Hydraulic working temperatures</i>	14	<i>Compatibility test</i>	32
<i>Hydraulic back pressures</i>	15	<i>Mechanical setting of selector valve and throttle valve</i>	35
<i>Test equipment required</i>	16	<i>Coarse setting of selector and throttle valves</i>	36
<i>Starting and stopping a.c. generators under test</i>	18	<i>Fine setting of selector and throttle valves</i>	38
<i>Test preparations</i>	20	<i>Functional testing after mechanical adjustment</i>	46
<i>Hydraulic test bench</i>	21	<i>Voltage and frequency tests</i>	47
<i>Test console</i>	22	<i>Overall functional tests</i>	48
<i>Test console switch settings</i>	23		

LIST OF TABLES

	<i>Table</i>
<i>A.C. generator output tests</i>	1
<i>Voltage and frequency tests</i>	2

Introduction

1. The tests detailed in this appendix are intended to prove the serviceability of the B.507 a.c. generator, its associated control unit and capacitor and junction box during first and second line servicing operations.

(2) Load unit, BT.2701 (Ref. No. 5G/3981).

(3) Trolley, hydraulic servicing, Mk.3 (Ref. No. 4F/3613).

FIRST LINE TESTING**Test equipment required**

2. The following items of equipment are required when testing the generator and associated equipment in an aircraft.

(1) Monitor unit, BT.2702 (Ref. No. 5G/3980).

Preparation for testing

3. The following operations should be completed in preparation for testing the generator and its associated equipment:

(1) Connect the 10-way cable B.T. 1137A between the load unit and the aircraft a.c. generator test plug, PL RJ28.

(2) Connect the 18-way cable B.T.

RESTRICTED

1013A between the monitor unit and the load unit.

(3) Set the load unit LOAD RATING switch to the 1.2kW position.

(4) Set the monitor unit, D.C. ON switch to ON: ensure that the cooling fans in the load unit are operating.

(5) Ensure that the monitor unit MEAN/PEAK lamp lights.

(6) Connect the hydraulic servicing trolley to the aircraft hydraulic couplings.

(7) Start the servicing trolley and check that the oil inlet pressure is between 2650 lb/in² and 3050 lb/in².

A.C. generator output tests

4. The frequency and voltage outputs of the a.c. generator are measured by using the monitor unit. The following switch settings and observations should be made:

(1) Set the MONITOR POINT switch to ALT.

(2) Set the LOAD RANGE switch to position 2.

(3) Set and hold the ALT ON switch for the duration of all tests.

(4) Ensure that the ALT RUNNING lamp lights.

(5) Ensure that indications appear on the volt and deviation meters.

(6) Make the switch settings and compare the results obtained with those set out in Table 1.

Conclusion of testing

5. When the tests detailed in Table 1 are completed, the following operations are to be performed.

(1) Release the ALT ON switch (Monitor).

(2) Ensure that the a.c. generator runs down and that the ALT RUNNING lamp is extinguished (Monitor).

(3) Set the D.C. ON switch to the OFF position (Monitor).

(4) Stop the hydraulic test rig.

(5) Disconnect the hydraulic servicing trolley hoses and the electrical cables.

6. If the 3 MIN WARNING lamp is lighted, the following action should be taken.

(1) Release the ALT ON switch.

(2) After an interval of approximately 1 minute, repeat the operations detailed in para. 5 and Table 1.

SECOND LINE TESTING

General

7. Second line testing is performed when the B507 a.c. generator has been removed from an aircraft at those intervals prescribed by the relevant servicing schedule or determined by circumstance; e.g. failure of an a.c. generating system during first line testing.

8. The methods of testing to be used and the types of information to be gained are described in principle in para. 25 to para. 30:

TABLE 1
A.C. Generator Output Tests

Switch position		Meter indications		
Monitor point	Load range	Volts (mean)	Frequency deviation	Volts (peak)
ALT	1	± 5V	± 100 c/s	} Not in red limits
ALT	2	Within blue limits	Within blue limits	
ALT	3	Within blue limits	± 100 c/s	
ALT	4	± 5V	± 100 c/s	

RESTRICTED

additional instructions affecting the chronological order of testing may be published in Vol. 4, Part 6.

9. Information relating to the following characteristics of the a.c. generator is obtained during testing:

- (1) Any frequency deviation from the nominal of 2.4kc/s.
- (2) Any voltage from the nominal of 104V (mean).
- (3) The percentage of modulation present on the voltage waveform envelope resulting from any sub-harmonic content of the voltage waveform.
- (4) The magnitude of peak voltages appearing in the voltage output.
- (5) The behaviour of the a.c. generator in varying combinations of hydraulic inlet pressure, outlet back pressures and resistive loads as shown by:
 - (a) Changes in the magnitude of the generator transducer (throttle) currents.
 - (b) Changes in the magnitude of the generator field currents.
- (6) The ability of the generator to respond to a control unit within a specified time after the generator has been 'crash started'.

10. The a.c. generator is tested by means of the B.T.2780 second line electronic test console and is controlled during testing by the slave control unit which is a component of the second line test set. The test console and the slave control unit are described in A.P. 4343S, Vol. 1, Book 2, Sect. 9, Chap. 9 and 10. In addition a capacitor and junction box of known performance is used to complete the a.c. generating system.

11. The test console and associated equipment form the standard against which the components of the B507 generating system are tested: all a.c. generators and control units satisfactorily tested against this standard are regarded as electrically compatible and interchangeable. Instructions on the method used to verify the compatibility of a.c. generators and control units are given in para. 32 to para. 34.

12. In addition to the general test procedures, a special procedure to be applied to the setting of the generator selector and throttle valves and to subsequent testing is given in para. 35 to para. 44. This procedure is not included with the general procedure as it does not constitute a standard serviceability test.

Hydraulic supplies

13. The generator under test is supplied with hydraulic fluid to specification DTD585 under the required pressures by the H.M.L. Test Bench, Ref. No. 4G/6087: information on this installation is given in A.P.4743. It is essential that personnel responsible for testing B507 a.c. generators should be conversant with the operating instructions relating to this hydraulic installation in order that references in the subsequent testing procedures to (for example) inlet pressures, back pressures, flow rates and starting methods may be understood readily.

Hydraulic working temperatures

14. The hydraulic fluid supplies must be maintained in all test conditions at $\pm 5^{\circ}\text{C}$ within the temperature range $+30^{\circ}\text{C}$ to $+50^{\circ}\text{C}$.

Hydraulic back pressures

15. It is important to note that no back pressure is to be applied to the hydraulic system during the performance of any of the testing procedures unless specific instructions are given: e.g. as in para. 28 and para. 29.

Test equipment required

16. The following test equipment and supplies are necessary to perform the testing procedures:

- (1) Electronic test console type B.T. 2780, Ref. No. 5G/4191.
- (2) Slave control unit, supplied with the console.
- (3) Serviceable capacitor and junction box type C/E2/20A, Ref. No. 5UC/6925.

Note . . .

The value of the resonating capacitor contained within the capacitor and junction box must be $8.5 \mu\text{F} \pm \frac{1}{2}\%$, which tolerance is closer than that used for normal production purposes. In order to define in precise terms the

performance of the generator, the tolerance on the capacitor must be restricted as resonating capacitance affects the value of the field current obtained. The use of a capacitor of wider tolerance than that quoted would entail compensation to the value of field current readings so obtained.

- (4) Hydraulic adapters, supplied with the console and used in connection with (10).
 - (5) H.M.L. Hydraulic Test Bench, Ref. No. 4G/6087.
 - (6) Voltmeter, a.c. 0-150V Ref. No. 5QP/25256.
 - (7) Stopwatch, Ref. No. 6B/9101001.
 - (8) Transparent test cover Ref. No. (H.S.D.) B.T.20088.
 - (9) Water cooling supply for H.M.L. test bench at 10 gal/min (approx).
 - (10) Flexible hose for hydraulic connections.
 - (11) A.C. mains supply at 110-250V, 50/60c/s.
 - (12) Load unit, air cooled, Ref. No. 5G/3201.
17. With reference to item (6) of para. 16 (a.c. voltmeter), this instrument is used for measuring generator voltage outputs in r.m.s. terms in order that load currents may be measured and the applied load calculated from the r.m.s. voltage \times by the current reading obtained. This method of load calculation is used when the VARIAC control is used in conjunction with the FINE LOAD CONTROL position of the FINE LOAD CONTROL/OFF/CONTROLLER TEST INPUT switch. The voltmeter is connected across poles J and K of SKT23 (C.R.O.) where the generator output is tapped by setting the CONTROLLER IN. VOLTS/ALTERNATOR OUT VOLTS switch to ALTERNATOR OUT VOLTS: the load current is measured on METER-A using the appropriate position of the RANGE-A-MILLIAMPS switch in conjunction with the 2.4KC/S LOAD RANGE X 100 position of the SELECTOR A switch. For normal test purposes the generator output is measured in terms of mean voltage on the VOLTS MEAN meter.

Starting and stopping a.c. generators under test

18. There are two methods of starting and stopping a.c. generators under test:

- (1) By means of manual operation of the INCHING CONTROL VALVE on the hydraulic test bench (para. 26).
- (2) By means of electrical operation of the solenoid valve on the hydraulic test bench in pre-set pressure conditions, using the SLAVE ALT START switch on the test console (para. 30).

19. The first method is employed when running up the generator initially in order to maintain close control over the generator: this method is also used when detailed observations of performance in varying conditions of load and hydraulic pressures are being made. The second method, known as 'crash starting' is used when operational service conditions are being simulated. In operational practice all starting of B507 a.c. generators is made in 'crash start' conditions.

Test preparations

20. The following operations are necessary in preparation for testing:

21. *Hydraulic test bench:*

- (1) Mount the generator under test on the hydraulic test bench using the securing clamps and wooden packing segments provided.
- (2) Using the appropriate hydraulic adapter, connect the generator high pressure inlet to BENCH MANIFOLD No. 2.
- (3) Using the appropriate hydraulic adapter, connect the generator low pressure output to the RETURN MANIFOLD.
- (4) Connect the necessary power supplies to the test bench.
- (5) Connect the cooling water supplies to the hydraulic oil cooler.
- (6) Set the BENCH MANIFOLD SELECTOR to the neutral (central) position.
- (7) Set fully counter clockwise:
 - (a) INCHING CONTROL VALVE.
 - (b) No. 2 MANIFOLD NEEDLE VALVE.

- (8) Set the BACK PRESSURE VALVE fully open.
- (9) Press the START button.
- (10) Set the BY PASS VALVE to LOAD.
- (11) Adjust the H.M.L. ELECTRAULIC FLOW VALVE to 2.83 gal/min as indicated on the ELECTRAULIC FLOW METER.
- (12) Set the BENCH MANIFOLD SELECTOR to the No. 2 position.
- (13) Set the PRESSURE REGULATOR to 2800lb/in².

22. Test console

- (1) Connect the mains supply.
- (2) Mount and secure to the test console:
 - (a) The slave control unit.
 - (b) The capacitor and junction box using the wooden packing pieces provided.
- (3) Set up and calibrate the test console in accordance with the instructions given in A.P.4343S, Vol. 1, Book 2, Sect. 9, Chap. 11.

Test console switch settings

23. Make the following switch and/or control settings:

- (1) Frequency and waveform analysis panel:
 - (a) Set the POWER UNIT SELECTOR switch to position 2 and allow a warming up period of 20 min. (OVEN HEATING).
 - (b) Do not disturb the calibrated setting of the DISCRIMINATOR SET ZERO control.
 - (c) Set the FREQUENCY DEVIATION RANGE switch to $\pm 5\%$.
 - (d) Set the MEAN VOLTS ZERO switch to OFF.
 - (e) Set the MODULATION switch to OFF.
 - (f) Do not disturb the calibrated setting of the AMPLIFIER SET ZERO control.
 - (g) Set the OPERATE/RUN UP AND AMPLIFIER ZERO switch to RUN UP AND AMPLIFIER ZERO.

(h) Set the OUTPUT MULTIPLIER control fully counter clockwise.

(i) Set the OPERATE/CALIBRATE switch to OPERATE.

(j) Set fully counter clockwise of the SET P.A. DRIVE control and the SET P.A. REGULATOR control.

(k) Do not disturb the calibrated setting of the SET OSCILLATOR control.

(l) Set the C.R.T. DISPLAY SELECTOR to CHECK ALTERNATOR.

(m) Set the OSCILLATOR RANGE d/s switch to 2330-2470.

(2) Meter panel:

(a) Set RANGE-A MILLIAMPS to 100.

(b) Set RANGE-B MILLIAMPS to 300.

(c) Set RANGE-C MILLIAMPS to 250.

(d) Set RANGE-D VOLTS to OFF.

(e) Set SELECTOR A to 2.4KC/S LOAD RANGE x 100.

(f) Set SELECTOR B to TRANS-DUCER 2.

(g) Set SELECTOR C to CONT FIELD.

(h) Set SELECTOR D to EXTN'L.

(3) Load control and control unit test panel:

(a) Set all ALTERNATOR LOAD switches to OFF.

(b) Set the SLAVE ALT START switch to the up (off) position.

(c) Set the CONTROLLER IN. VOLTS/ALTERNATOR OUT VOLTS to ALTERNATOR OUT VOLTS.

(d) Connect the voltmeter across poles J and K of the C.R.O. socket.

(e) Set the FINE LOAD CONTROL/OFF/CONTROLLER TEST INPUT switch to OFF.

(f) Set the SET VOLTS control to the midway position.

(g) Do not disturb the pre-set position of the SET D.C. VOLTS control.

(h) Set the CONTROLLER switch to NORMAL.

- (i) Set the AUTO MAKE/RESET/AUTO BREAK switch to RESET.
- (j) Set the C.R.O. switch to ALT. TEST.
- (k) Set the SET FREQUENCY control to the mid-way position.
- (l) Set the VARIAC fully counter-clockwise.

Test interconnections

24. Make the following interconnections in addition to those previously made:

- (1) Connect the CONDENSER socket on the test console to PL RJ24 on the capacitor and junction box.
- (2) Connect the SLAVE CONTROLLER socket on the test console to PL RJ26 on the slave controller.
- (3) Connect the CONTROLLER plug (18 pole) on the test console to SKT RJ24 on the slave controller.
- (4) Connect poles A and C of SKT RJ25 on the slave controller to the corresponding poles of the oil solenoid electrical connection on the hydraulic test bench.
- (5) Connect the 115V IN plug on the test console to SKT RJ23 on the capacitor and junction box.
- (6) Connect SKT RJ22 on the a.c. generator to PL RJ22 on the capacitor and junction box.
- (7) Connect PL RJ21 on the a.c. generator to SKT RJ21 on the capacitor and junction box.
- (8) Connect PL RJ20 on the a.c. generator to SKT RJ20 on the capacitor and junction box.
- (9) Connect SKT32 on the test console to the air cooled load unit.

Test procedure

Test 1

25. Perform the following operations:

- (1) Check the frequency calibration and return the C.R.T. DISPLAY SELECTOR to CHECK ALTERNATOR.
- (2) Switch to ON DIRECT a load of 500W, using the appropriate ALTERNATOR LOAD switch.
- (3) Set the SLAVE ALT START switch to the down (on) position: check

that METER-C indicates $50 \text{ mA} \pm 10 \text{ mA}$: set RANGE-C MILLIAMPS to 1000.

- (4) Run up the generator manually [para. 18, sub-para. (1)] and adjust the pressure regulator to 2800 lb/in^2 .
- (5) Set the OPERATE/RUN UP AND AMPLIFIER ZERO to OPERATE.

(6) Note the reading on the FREQUENCY DEVIATION % meter: zero the meter needle using the SET FREQUENCY CONTROL.

Note . . .

If it is not possible to zero the FREQUENCY DEVIATION % meter within a period of 10s, set the SLAVE ALT START to up (off) and remove the hydraulic inlet pressure. In these circumstances the a.c. generator is regarded as unserviceable.

- (7) Adjust the SET VOLTS control as necessary to give a reading of $115\text{V} \pm 2\text{V}$ r.m.s. on the voltmeter.
- (8) Set the FINE LOAD CONTROL/OFF/CONTROLLER TEST INPUT switch to FINE LOAD CONTROL.
- (9) Adjust the VARIAC control to give a reading of 5.22A on METER-A indicating that a load of 600W is being applied to the generator output (para. 17).
- (10) Obtain a stationary Lissajous figure on the c.r.t. by means of the OSCIL-LATOR FREQUENCY control.
- (11) Note the reading on the OSCIL-LATOR FREQUENCY dial outer scale: this reading should be between 2.395 and 2.405kc/s. Use the SET FREQUENCY control as necessary to achieve this reading.
- (12) Set the MEAN VOLTS ZERO switch to 105.5.
- (13) Note the reading on the VOLTS MEAN meter: it should be between -1.5 and -0.5. Use the SET VOLTS control to achieve this reading.

Note . . .

The SET FREQUENCY and SET VOLTS control settings should not be disturbed during the remaining test procedures.

- (14) Note the reading on the PEAK VOLTS scale of M2: it should give an indication of not greater than 185.
- (15) Note the reading on METER-C: it should give an indication of 395 ± 100 .
- (16) Set the MODULATION switch to 3%.
- (17) Note the reading on the MODULATION % meter: the reading should not be in excess of 2.
- (18) Set SELECTOR A to TRANS-DUCER 1.
- (19) Set RANGE-A MILLIAMPS to 300.
- (20) Subtract the reading on METER-B from that on METER-A: the result should give a figure of zero ± 10 .

Test 2

26. Perform the following operations:

- (1) Check the frequency calibration and return the C.R.T. DISPLAY SELEC-TOR to CHECK ALTERNATOR.
- (2) Set the VARIAC control fully counter-clockwise.
- (3) Set the FINE LOAD CONTROL/OFF/CONTROLLER TEST INPUT switch to OFF.
- (4) Remove the 500W load by setting the relevant ALTERNATOR LOAD switch to OFF: check that the oil inlet pressure is 2800 lb/in².
- (5) Obtain a stationary Lissajous figure on the c.r.t. by means of the OSCIL-LATOR frequency control.
- (6) Note the reading on the OSCIL-LATOR FREQUENCY dial outer scale: this reading should be within 20c/s of that measured in Test 1.
- (7) Note the reading on the MOD-ULATION % meter: the reading should not be in excess of 2.

Test 3

27. Perform the following operations:

- (1) Check the frequency calibration and return the C.R.T. DISPLAY SELEC-TOR to CHECK ALTERNATOR.

- (2) Increase the hydraulic inlet pressure to 3050 lb/in².
- (3) Set RANGE-A MILLIAMPS to 100.
- (4) Set SELECTOR A to 2.4kc/s LOAD RANGE x 100.
- (5) Set the FINE LOAD CONTROL/OFF/CONTROLLER TEST INPUT switch to FINE LOAD CONTROL.
- (6) Adjust the VARIAC control to give a reading of 0.87A on METER-A, indicating that a load of 100W is being applied to a generator output of 115V r.m.s.
- (7) Obtain a stationary Lissajous figure on the c.r.t. by means of the OSCIL-LATOR FREQUENCY control.
- (8) Note the reading on the OSCIL-LATOR FREQUENCY dial outer scale: this reading should not be greater than 2.45kc/s.
- (9) Note the reading on the VOLTS MEAN meter: it should not be greater than +1.
- (10) Note the reading on METER-C: it should give an indication of 340 ± 100 .
- (11) Note the reading on the PEAK VOLTS scale of M2: it should give an indication of not greater than 185.
- (12) Set RANGE-A MILLIAMPS to 300.
- (13) Set SELECTOR A to TRANS-DUCER 1.
- (14) Subtract the reading on METER-B from that on METER-A: the result should be a figure not greater than 70.

Test 4

28. Perform the following operations:

- (1) Check the frequency calibration and return the C.R.T. DISPLAY SELEC-TOR to CHECK ALTERNATOR.
- (2) Switch to ON DIRECT an additional load of 500W, using the relevant ALTERNATOR LOAD switch.
- (3) Set RANGE-A MILLIAMPS to 100.

(4) Set SELECTOR A to 2.4kc/s LOAD RANGE x 100.

(5) Check that METER-A gives a reading of 5.22A indicating that a load of 600W is being applied to a generator output of 115V r.m.s.

(6) Decrease the hydraulic inlet pressure to 2650 lb/in².

(7) Apply 100 lb/in² BACK PRESSURE by means of the BACK PRESSURE VALVE on the hydraulic test bench.

(8) Obtain a stationary Lissajous figure on the c.r.t. by means of the OSCILLATOR FREQUENCY control.

(9) Note the reading on the OSCILLATOR FREQUENCY dial outer scale: this reading should be not less than 2.35 kc/s.

Test 5

29. Perform the following operations:

(1) Check the frequency calibration and return the C.R.T. DISPLAY SELECTOR to CHECK ALTERNATOR.

(2) Maintain an hydraulic inlet pressure of 2650 lb/in² and a back pressure of 100 lb/in².

(3) Remove the load applied by the VARIAC control by setting the control fully counter-clockwise: set the FINE LOAD CONTROL/OFF CONTROLLER TEST INPUT switch to OFF.

(4) Switch to ON DIRECT an additional load of 500W, using the relevant ALTERNATOR LOAD switches.

(5) Set RANGE-A MILLIAMPS to 100.

(6) Set SELECTOR A to 2.4kc/s LOAD RANGE x 100.

(7) Note the reading on METER-A: it should indicate 8.7A with the generator output at 115V r.m.s. showing that a load of 1000W is being applied to the generator output.

(8) Obtain a stationary Lissajous figure on the c.r.t. by means of the OSCILLATOR FREQUENCY control.

(9) Note the reading on the OSCILLATOR FREQUENCY dial outer scale: it should be not less than 2.35kc/s.

(10) Set the MEAN VOLTS ZERO switch to 103.5.

(11) Note the reading on the VOLTS MEAN meter: it should be not greater than - 2.

(12) Note the reading on the PEAK VOLTS scale of M2: it should give an indication of not greater than 185.

(13) Note the reading on METER-C: it should give an indication of 455 ± 100 .

(14) Set RANGE-A MILLIAMPS to 300.

(15) Set SELECTOR A to TRANSDUCER 1.

(16) Subtract the reading on METER-B from that on METER-A: the result should give a figure of not greater than 80.

(17) Note the reading on the MODULATION % meter; the reading should not be in excess of 2.

(18) Check the oil flow rate: it should not exceed 2.83 gal/min.

Test 6 (crash start)

30. Perform the following operations:

(1) Check the frequency calibration and return the C.R.T. DISPLAY SELECTOR to CHECK ALTERNATOR.

(2) Remove the BACK PRESSURE from the hydraulic test bench by opening fully the BACK PRESSURE VALVE.

(3) Remove the 1000W load by setting the relevant ALTERNATOR LOAD switches to OFF.

(4) Increase the hydraulic inlet pressure to 2800 lb/in².

(5) Obtain a stationary Lissajous figure on the c.r.t. by means of the OSCILLATOR FREQUENCY control.

(6) Set RANGE-A MILLIAMPS to 100.

(7) Set selector A to 2.4kc/s LOAD RANGE x 100.

(8) Set the FINE LOAD CONTROL/OFF/CONTROLLER TEST INPUT switch to FINE LOAD CONTROL.

(9) Adjust the VARIAC control to give a reading on 0.87A on METER-A

indicating that a load of 100W is being applied to a generator output of 115V r.m.s.

(10) Stop the generator by operating No. 2 MANIFOLD NEEDLE VALVE.

(11) Set the SLAVE ALT START switch to up (off).

(12) Return the No. 2 MANIFOLD NEEDLE VALVE to its former position.

(13) Perform the following operations simultaneously.

(a) Set the SLAVE ALT START switch to down (on)

(b) Start the stop-watch

(14) Measure the time taken for the Lissajous figure to return to a stationary condition: this time should not exceed 5s.

(15) Repeat operations (10) to (14) inclusive three times.

Conclusion of testing

31. At the conclusion of the performance of Tests 1 to 6 inclusive the following procedure should be adopted:

(1) Set the SLAVE ALT START switch to up (off).

(2) Shut down the hydraulic test bench.

(3) Disconnect all hydraulic and electrical connections from the a.c. generator and remove the a.c. generator from the hydraulic test bench.

(4) Disconnect and remove the a.c. voltmeter.

(5) Set the A.C. MAINS switch to OFF.

Compatibility test

32. The compatibility of components of B507 a.c. generator systems (i.e. a.c. generators and control units tested separately and using a slave control unit as a standard) is verified by adopting the procedure detailed in para. 33 to para. 34. It may be considered necessary to make adjustments of a small order to the externally located potentiometers of the control unit, RV151 (voltage) and RV152 (frequency).

33. The following substitutions must be

made when applying the instructions detailed in para. 34:

(1) Substitute 'control unit' for 'slave control unit'.

(2) Substitute 'ALTERNATOR START' for 'SLAVE ALTERNATOR START'.

(3) Substitute RV151 for 'SET VOLTS'.

(4) Substitute RV152 for 'SET FREQUENCY'.

34. The following instructions should be followed during compatibility testing:

(1) Perform the operations detailed in para. 21 to para. 23.

(2) Make all electrical connections as shown in fig. 2 of A.P. 4343S, Vol. 1, Book 2, Sect. 9. Chap. 9.

(3) Perform tests 1 to 6 inclusive, bearing in mind the information contained in the Note following sub-para. 3 of para. 16. If during the performance of Test 1 the limits of $\pm 5c/s$ frequency cannot be achieved by reason of the cumulative effects of tolerances, the limits may be extended to $\pm 15c/s$.

Mechanical setting of selector valve and throttle valve

35. It is necessary to check the mechanical setting of the selector and throttle valves after dismantling and reassembly. If any maladjustment is apparent the instructions contained in para. 36 to para. 40 should be applied followed by the functional tests detailed in para. 46 to para. 48.

Course setting of selector and throttle valves

36. Perform the following operations:

(1) Apply the instructions contained within para. 21 with the exception of sub-para. (13).

(2) Remove the throttle cover from the motor casing.

(3) Check that the four screws retaining the throttle lever to the mounting pad are positioned approximately centrally in the kidney slots of the throttle lever.

(4) Fit the transparent test cover to the

motor casing and ensure that it constitutes an oil tight seal.

(5) Operate the INCHING CONTROL VALVE slowly clockwise until the motor inlet pressure is approximately 50 lb/in².

(6) Check that the throttle potentiometer is positioned centrally on the potentiometer track: note the actual position.

(7) Set the INCHING CONTROL VALVE fully counter-clockwise.

37. Should the throttle potentiometer wiper require adjustment (i.e. if it is offset toward either extremity), perform the following operations:

(1) Remove the transparent test cover.

(2) Slacken the locknut on the selector valve adjusting screw.

(3) If it is necessary to rotate the potentiometer wiper in a clockwise direction to centralise it, unscrew the selector valve adjusting screw: screw in the adjusting screw if movement in a counter clockwise direction is required to centralise the wiper.

Note . . .

Small adjustments only should be made to the selector valve adjusting screw.

(4) Refit the transparent test cover.

(5) Apply an hydraulic inlet pressure of 50 lb/in².

(6) Check that the potentiometer wiper is in a central position on the potentiometer track.

(7) Repeat as necessary the adjustment procedure in sub-para. (1) to (6), removing the hydraulic inlet pressure before removing the transparent test cover.

(8) Remove the transparent test cover.

(9) Lock the selector valve adjusting screw by tightening the locknut.

(10) Refit the transparent test cover.

Fine setting of selector and throttle valve

38. For fine setting of the selector and throttle valves it is necessary to use the test console and its associated equipment. Perform the following operations:

(1) Apply the instructions contained within para. 22.

(2) Make the test console switch settings as indicated in para. 23.

(3) Make the electrical connections as indicated in para. 24.

(4) Check the frequency calibration and return the C.R.T. DISPLAY SELECTOR to CHECK ALTERNATOR.

(5) Set the SLAVE ALT. START switch to down (on).

(6) Check that METER-C indicates 50 ± 10 .

(7) Set the MEAN VOLTS ZERO switch to 103.5.

(8) Switch ON DIRECT of 500W using the appropriate ALTERNATOR LOAD switch.

(9) Run up the generator by means of the INCHING CONTROL VALVE until a stationary Lissajous figure is obtained on the c.r.t. indicating an output frequency of 2.4kc/s. Maintain the Lissajous figure by means of manual hydraulic inlet control.

Note . . .

The hydraulic inlet pressure must not rise above 3100 lb/in².

(10) By means of the FINE LOAD CONTROL position of S2 and the VARIAC control increase the load to 600W. Note the reading on METER-A: it should indicate 5.22A at an output voltage of 115V r.m.s.

(11) Adjust the SET VOLTS control to give a reading of +1 on the VOLTS MEAN meter.

(12) Set SELECTOR A to TRANSDUCER 1.

(13) Set RANGE-A MILLIAMPS to 300.

(14) Vary the hydraulic inlet pressure through the range 2650 lb/in² to 3050 lb/in².

(15) Check that the indications on METER-A and METER-B are equal at an hydraulic inlet pressure of $2800 \text{ lb/in}^2 \pm 20 \text{ lb/in}^2$. The equal indications of the two meters would demonstrate that the selector valve setting has been correctly made.

RESTRICTED

39. If it is not possible to achieve the results set out in para. 38, sub-para. (15), proceed as follows:

- (1) Adjust the hydraulic inlet pressure until the transducer currents indicated on METER-A and METER-B are equal.
- (2) Note the hydraulic inlet pressure at which equality of meter readings occur.
- (3) Remove the 600W load.
- (4) Set the SLAVE ALT. START switch to up (off).
- (5) Remove the hydraulic inlet pressure.
- (6) Remove the transparent test cover.

40. Make one or other of the following adjustments to the selector valve adjusting screw and test the results as indicated.

- (1) If the currents indicated on METER-A and METER-B are equal at an hydraulic pressure below 2780 lb/in², screw in the selector valve adjusting screw.
- (2) If the currents indicated on METER-A and METER-B are equal at an hydraulic pressure above 2820 lb/in² screw out the selector valve adjusting screw.

41. Test the results of adjustments made as detailed in para. 40 as follows:

- (1) Refit the transparent test cover.
- (2) Repeat the procedures contained in para. 38, sub-para. (4) to para. 40 inclusive until the indications on METER-A and METER-B are equal at an hydraulic inlet pressure of 2800 lb/in² \pm 20 lb/in².
- (3) Adjust the output frequency to between 2.395kc/s and 2.405kc/s by means of the OSCILLATOR FREQUENCY control used in conjunction with the SET OSCILLATOR control: use the SET FREQUENCY control to achieve this reading.
- (4) If a large adjustment to the SET FREQUENCY control appears to be

necessary repeat the instructions contained within para. 39 and 40.

42. When the conditions of para. 41, sub-para. (3) are met satisfactorily, run the generator in accordance with the instructions given and in the following conditions:

- (1) At an inlet pressure of 2800 lb/in² \pm 20 lb/in².
- (2) On a load of 600 \pm 20W.

43. Check that the following conditions are satisfied:

- (1) The frequency is 2.4kc/s \pm 5c/s.
- (2) The readings on METER-A and METER-B are equal within a tolerance of \pm 5MA.

44. Check the potentiometer wiper position in the potentiometer track: it should be centrally located. Readjust the potentiometer wiper as necessary, applying the instructions contained within para. 37. Any adjustment to the potentiometer wiper at this stage would disturb the selector valve setting and, therefore, the instructions contained within para. 38 to 43 should be repeated.

Functional testing after mechanical adjustment

45. A complete functional test of the a.c. generator is required after mechanical adjustments have been made: this test falls into two parts:

- (1) Voltage and frequency tests under varying loads and hydraulic pressures.
- (2) Overall functional tests.

Voltage and frequency tests

46. Make the voltage and frequency tests by running the generator under the conditions set out in Table 2.

Note . . .

During the course of test 3, check the hydraulic oil flow rate: it should not exceed 2.83 gal/min.

Overall functional tests

47. Make the overall functional tests by performing tests 1 to 6 inclusive (para. 25 to 30 inclusive) after setting all switches and controls to the positions given in para. 23.

TABLE 2
Voltage and Frequency Tests

Test	Oil Inlet Pressure lb/in ²	Back Pressure lb/in ²	Load Watts	Frequency kc/s	Voltage Mean	Current Amp
1	3050	0	0	* 2.475	* 108	0
2	3050	0	1000	* 2.475	* 101.5	8.7
3	2650	100	1200	* 2.325	* 100	10.4
4	3050	0	100	* 2.450	* 106.5	0.87
5	2650	100	1000	* 2.350	* 101.5	8.7

RESTRICTED

This file was downloaded
from the RTFM Library.

Link: www.scottbouch.com/rtfm

Please see site for usage terms,
and more aircraft documents.



**TELEBRIEF
CONNECTIONS**

E