

Now 113B-0130-1

### Chapter 9

## A.C. GENERATORS, TYPE 158 SERIES

### LIST OF CONTENTS

	Para.		Para
<i>Introduction</i> .....	1	<i>Sliprings</i> .....	13
<b>Description</b>		<i>Exciter field assembly</i> .....	14
<i>General</i> .....	2	<i>A.C. stator assembly</i> .....	15
<i>Frame</i> .....	3	<i>Quill drive</i> .....	16
<i>Tail end, end-plate</i> .....	4	<i>Cooling</i> .....	17
<i>Ball bearing</i> .....	5	<b>Servicing</b>	
<i>Slipring brushgear</i> .....	6	<i>General</i> .....	18
<i>D.C. exciter brushgear</i> .....	7	<i>Carbon brushes</i> .....	19
<i>Driving end, end-plate</i> .....	8	<i>Felt lubrication pads</i> .....	20
<i>Roller bearing</i> .....	9	<b>Testing</b>	
<i>Rotor assembly</i> .....	10	<i>No load test</i> .....	22
<i>A.C. rotor (rotating field)</i> .....	11	<i>Insulation test</i> .....	23
<i>D.C. exciter armature</i> .....	12		

### LIST OF ILLUSTRATIONS

	Fig.		Fig.
<i>Generator, Type 158</i> .....	1	<i>Internal circuit diagram</i> .....	4
<i>Generator, Type 158B</i> .....	2	<i>No load test circuit</i> .....	5
<i>Generator, Type 158, sectioned assembly</i> .....	3		

### LIST OF APPENDICES

	App.
<i>A.C. generators, Type 158 variants</i> .....	1

## LEADING PARTICULARS

Generator a.c. Type 158 .....	Ref. No. 5UA/6332
Generator a.c. Type 158B .....	Ref. No. 5UA/6491
Generator a.c. Type 158C .....	Ref. No. 5UA/6606
Generator a.c. Type 158, Mk. 2.....	Ref. No. 5UA/6639
Rating .....	40 kVA, 3 phase, 400 C/S
Rated voltage .....	208 volts a.c.
Rated current .....	111 A.
Voltage regulator, Type 98A .....	Ref. No. 5UC/6544
Regulated voltage .....	200 volts a.c.
Nominal speed .....	6 000 rev/min
Power factor .....	.75
Overload (5 min.) .....	60 kVA
Overspeed (5 min.) .....	11 000 rev/min.
Exciter field voltage (max.) .....	50 volts
Exciter field current (max.) .....	8 A.
Minimum speed for regulation .....	5 400 rev/min
Maximum driving torque required .....	1 140 lb/in.
Operating altitude .....	0-69 000 feet
Rotation from drive end .....	Clockwise
Carbon brush grades .....	P.E.G.11 (Commutator and slipring)
Brush spring tension .....	20-26 oz. (Commutator and slipring)
Minimum brush lengths—	
D.C. brushes .....	$\frac{11}{16}$ in. on shortest side
Slipring brushes .....	$\frac{13}{16}$ in. on longest side
Total weight .....	99 lb.
Overall length .....	20 $\frac{1}{2}$ in.
Overall width .....	12 in.
Overall height .....	14 in.
Lubricating oil grade .....	D.E.D.2472 A/O

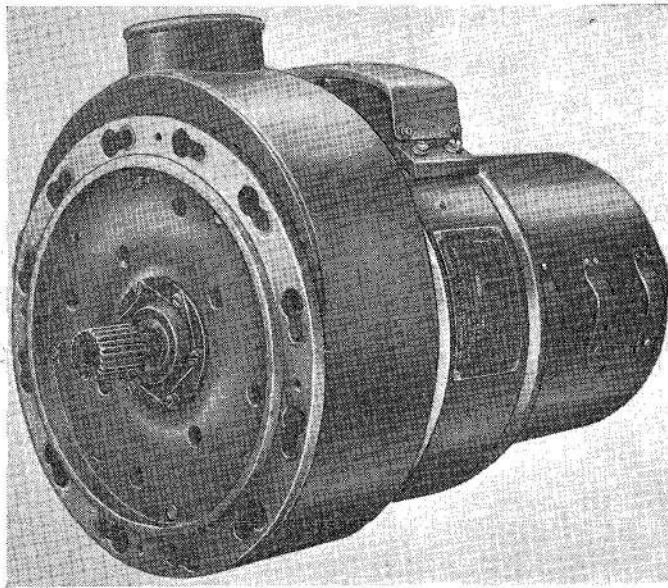

**Fig. 1. Generator, Type 158**

### Introduction

1. The type 158 series of a.c. generators are designed to supply power at constant frequency when driven by a constant speed drive and can be used singly or with one or more machines running in parallel. Details of the variants of the basic design are contained in App. 1 to this chapter. The constant frequency a.c. system is described in A.P.4343, Vol. 1, Sect. 2 and the constant speed drive in A.P.4670A, Vol. 1.

### DESCRIPTION

#### General

2. The basic type 158 has a salient construction, 8-pole rotor and an integral exciter incorporated on the rotor shaft, which is supported in roller

**RESTRICTED**

and ball bearings at the driving end and tail end respectively. The exciter is provided with interpoles and a compensating winding to ensure good commutation under varying loads and conditions. A quill shaft is used and the machine incorporates a button-hole type mounting flange which facilitates installation and removal of the generator from its mounting bracket in the aircraft.

### Frame

3. The frame is a light alloy machined casting, housing the rotor and carrying the stator windings and a.c. output terminal block.

### Tail end, end plate

4. The TE. end-plate is a light alloy machined casting which carries the exciter field assembly, interpoles, d.c. brushgear assembly, slipping brushgear assembly and d.c. exciter terminal block, and houses the ball bearing which supports the tail end of the rotor shaft. The end-plate is secured by six tie bolts ( $\frac{1}{4}$  in. 28 UNF 2B) which pass through the frame, and are mated with six stiffnuts and washers on the inner face of the frame at the driving end.

### Ball bearing

5. The ball bearing on the d.c. end of the rotor shaft is a push fit into a bearing insert mounted in the T.E. end-plate. The inner race of the bearing is a light interference fit on the rotor shaft and is held in position on the shaft by a sleeve, secured by a bearing lock-nut which is in turn locked by a spring clip. The outer race is held in position by the inner and outer bearing caps. The outer cap is held in position by three 2 B.A. cheese head screws which pass through the endplate and bearing bush insert and screw into three of the six holes in the split T.E. bearing clamp. The inner bearing cap is secured by the split T.E. bearing clamp, three 2 B.A. cheese head screws passing through the end-

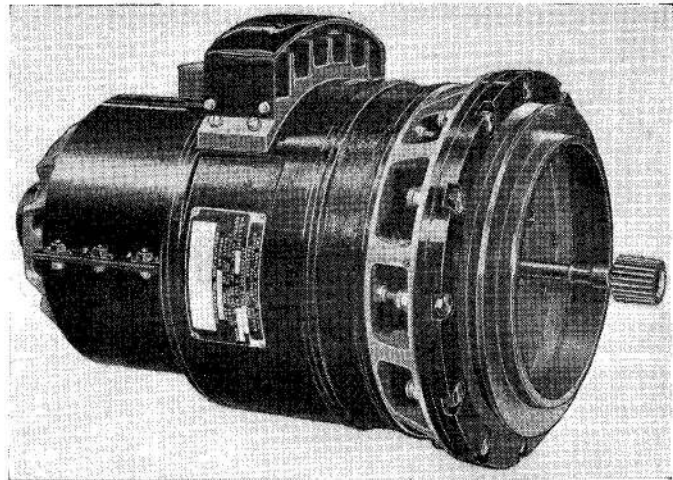

Fig. 2. Generator, Type 158B

plate and the bearing bush insert, and mating with the three alternate holes not already utilised by the screws securing the outer bearing cap. Briefly, the inner bearing cap clamp is secured by six screws, three of which are also utilised for securing the outer bearing cap. The bearing caps house felt washers which are inserted in annular recesses on each side of the bearing and absorb sufficient oil to maintain the lubrication of the bearing between servicing periods. The felt pads are retained in position by a brass bearing shield.

### Slipping brushgear

6. The slipping brushgear comprises two positive and two negative brush boxes each carrying a single brush. The brush connections are made to positive and negative bus-bars which are mounted on opposite faces of the brushgear mounting plate and to which connections are made from the d.c. exciter.

### D.C. exciter brushgear

7. The d.c. exciter brushgear comprises three positive and three negative brush boxes attached to the mounting ring and connected to positive and negative bus-ring assemblies respectively. Both the slipping and d.c. brushgear assemblies are mounted on the brush rocker plate. When in position in the

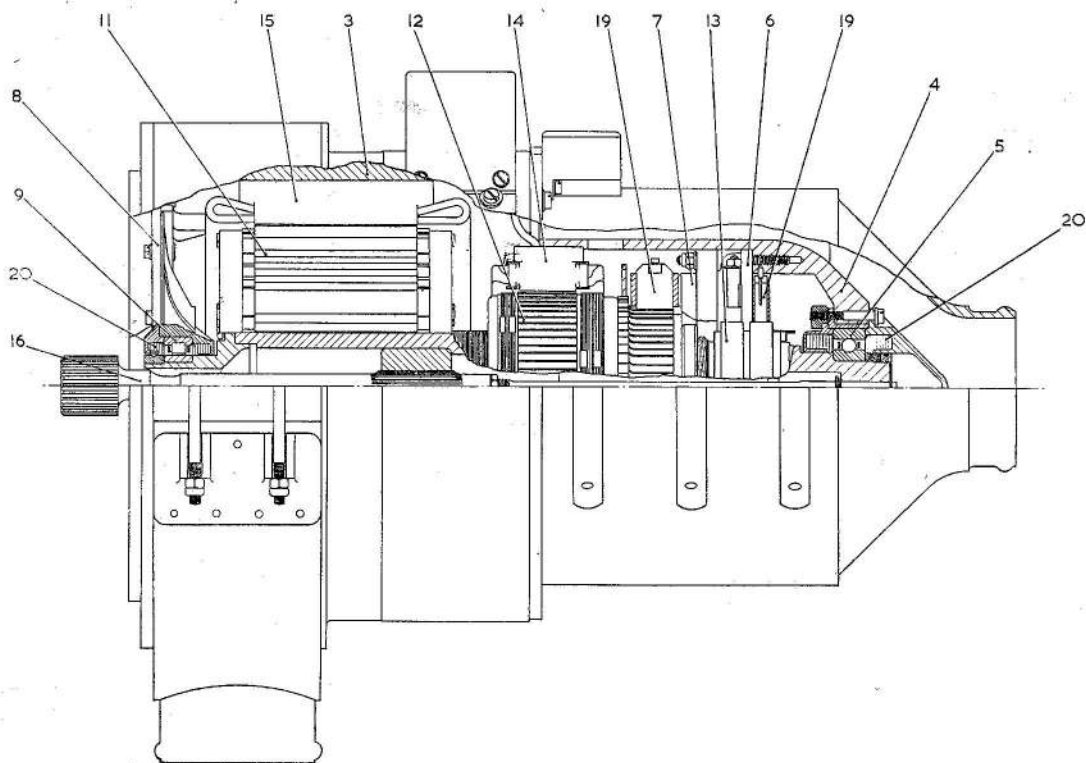

- |          |                        |           |                        |
|----------|------------------------|-----------|------------------------|
| <b>3</b> | FRAME                  | <b>11</b> | A.C. ROTOR             |
| <b>4</b> | TAIL END—END PLATE     | <b>12</b> | D.C. EXCITER ARMATURE  |
| <b>5</b> | BALL BEARING           | <b>13</b> | SLIPRINGS              |
| <b>6</b> | SLIPRING BRUSHGEAR     | <b>14</b> | EXCITER FIELD ASSEMBLY |
| <b>7</b> | D.C. EXCITER BRUSHGEAR | <b>15</b> | A.C. STATOR ASSEMBLY   |
| <b>8</b> | DRIVING END—END PLATE  | <b>16</b> | QUILL DRIVE            |
| <b>9</b> | ROLLER BEARING         | <b>19</b> | CARBON BRUSHES         |
|          |                        | <b>20</b> | FELT LUBRICATION PADS  |

**Note . . .**

*The numbers in the key cross refer to the corresponding paragraphs which deal with the description of the components or sub-assembly in the text.*

**Fig. 3. Generator, Type 158, sectional assembly**

endplate the brushgear is secured by three studs which pass through the slipring brushgear mounting plate, spacing washers and the d.c. rocker plate, and are held by three stiffnuts on the face of the rocker plate. Three 2 B.A. cheese head screws also pass through the fluted portion of the T.E. endplate and into the d.c. rocker plate.

**Driving end, end-plate**

**8.** The D.E. endplate is a light alloy

machined casting which is drilled with eight holes to accept the attaching bolts securing the plate within its register in the frame. The endplate has a bearing housing bush insert, into which the outer race of the driving end roller bearing is a push fit.

**Roller bearing**

**9.** The outer race of the roller bearing is held in position by the bush insert and the D.E. outer cap, both of which are secured to

**RESTRICTED**

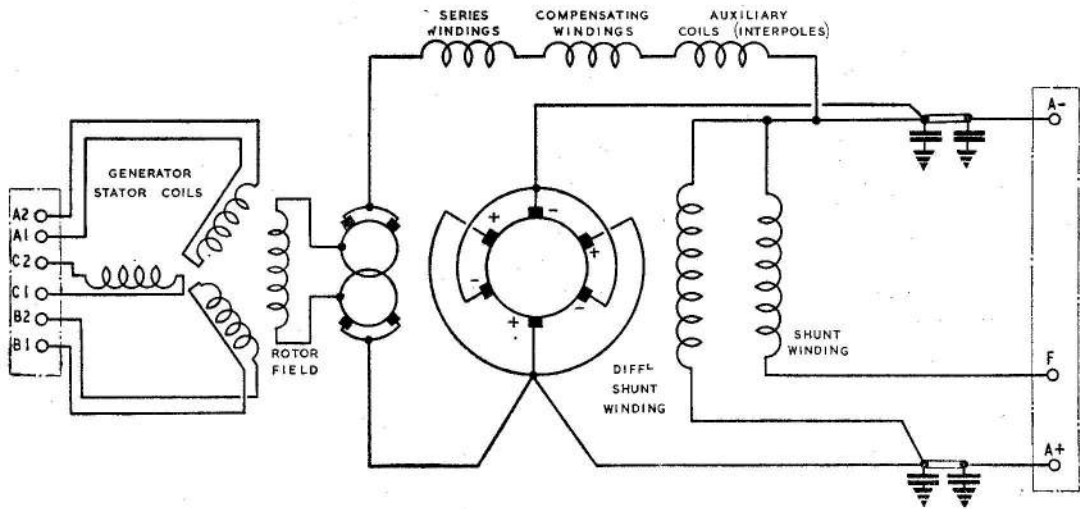

Fig. 4. Internal circuit

the D.E. endplate by six 2 B.A. cheese head screws which are drilled to accept 22 S.W.G. locking wire. The outer bearing cap and the bush insert are both recessed to accept felt pads which absorb sufficient oil to maintain the correct balance of oil-mist lubrication of the bearing between overhaul periods. The inner race of the bearing is a light interference fit on the a.c. end of the rotor shaft, the extreme end of which is stepped to

receive the D.E. sleeve, which is also a light interference fit on the shaft.

#### Rotor assembly

10. The shaft assembly is hollowed and comprises three major components; the shaft, inside which is pinned the splined bush engaging in the splines of the quill drive shaft, and the shaft end which is an

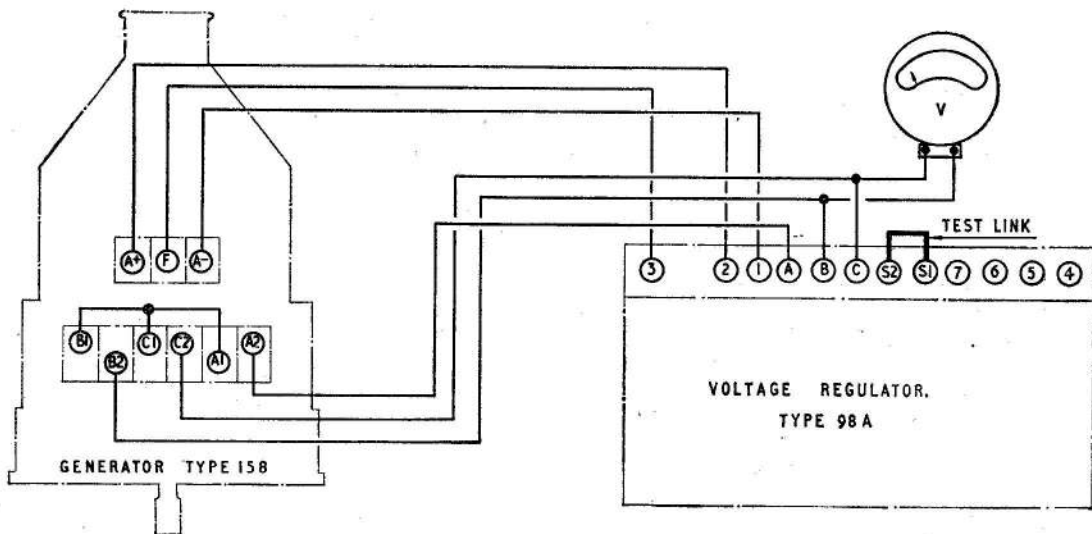

Fig. 5. No load test circuit

interference fit into the register at the end of the shaft and in addition is secured to the shaft by six ( $\frac{1}{4}$  in. UNF thread) hexagon head bolts and six tab washers.

#### **A.C. rotor (rotating field)**

11. At the driving end of the shaft is the rotating field rotor. This is of eight pole, salient construction with two coils on each pole piece and wound to give poles of alternate polarity. Balancing of the rotor is accomplished by means of balance weights screwed as required on to the ends of the pole shoes.

#### **D.C. exciter armature**

12. Mounted adjacent to the rotating field is the exciter armature assembly. This is progressive wave wound with 47 coils, the terminations of which are taken to the 47 segment commutator at the tail end of the armature assembly.

#### **Sliprings**

13. Midway between the armature assembly and the ball bearing at the tail end of the rotor shaft are mounted the two sliprings on to which the d.c. excitation current is fed from the d.c. exciter to the rotor windings. Two insulated supply leads to the rotor pass along machined slots in the shaft, inside the armature bush, and are brazed, one to each slipring connector strap. The outer slipring is the negative and the inner, the positive.

#### **Exciter field assembly**

14. The exciter field assembly comprises the following major components:—

- (1) Field winding, comprising six individual coils, each made up of shunt winding, differential shunt winding and series winding.
- (2) Six interpole assemblies.
- (3) Two compensating windings.
- (4) Six auxiliary windings.
- (5) Exciter yoke.
- (6) Six field poles of 53 laminations each.

The entire field assembly is secured into its position in the D.E. endplate by means of six 2 B.A. hexagon socket head screws which pass through the face of the endplate and screw into six clamping plates. When these screws are slackened, the field assembly is free to rotate within the T.E. endplate, thereby facilitating setting of the neutral position. Tommy bar holes are drilled in the outer diameter of the exciter yoke to assist in turning when setting the neutral position.

#### **A.C. stator assembly**

15. The stator is made up of approximately 230 laminations, has 84 slots on its inner diameter and is made up with the conductor slots skewed one slot width. The windings, comprising 84 coils, are two-layer bar-wound at  $3\frac{1}{2}$  slots per pole per phase, one turn per coil, two conductors per slot. The ends of the coils are brought out and connections made by brazing, the phase ends being brought out to six terminals on the a.c. output terminal block, which is mounted on the outside of the frame. The stator assembly is located in its position within the frame by four  $\frac{3}{16}$  in. silver steel dowel pins.

#### **Quill drive**

16. The quill drive incorporates a shear section to protect the constant speed drive in the event of damage or failure of the generator and vice versa. The splines of the drive are treated with Regent Caltex Crater Compound No. 2 during assembly and should not normally require any further application between overhaul periods.

#### **Cooling**

17. Air blast cooling is employed, air entering the generator at the entry on the tail end, passing over the conical shaped tail end bearing housing and endplate where deflector plates direct the airflow on to the sliprings, commutator assembly and brush-gear. From here the air passes along inside the frame, over the armature windings and through the a.c. rotor windings and d.c. exciter field windings, leaving the machine through the air outlet union which is attached to a cover band encircling the driving end of the frame. The air outlet union may be positioned anywhere in 360 deg. to suit individual installation requirements.

**RESTRICTED**

## SERVICING

### General

18. Before installation, a check should be made to ensure that all screws, bolts and electrical connections, etc., are tight and free from corrosion and that the rotor assembly is free to turn. The generator should be removed for bay servicing in accordance with the Aircraft Servicing Schedule.

### Carbon brushes

19. The carbon brushes should be checked at regular intervals to ensure sufficient length and freedom of movement in their respective brush boxes. New brushes should be fitted if the rate of wear indicates that the minimum length (as quoted under leading particulars) may be reached before the next servicing period or examination.

### Felt lubrication pads

20. Lubrication is by oil mist from saturated felt pads carried in non-spill housings at each side of the bearings. These felt pads are oiled during assembly of the machine and re-oiling should not be required between major servicing periods.

## TESTING

### No load test

21. Mount the generator on a test bench and connect as shown in fig. 4, using a Type 98A voltage regulator of proven serviceability. Ensure that the shorting link is in position between terminals S1 and S2 on the voltage regulator. With the generator driven at 6,000 r.p.m. the output voltage should be regulated at 200 volts.

### Note . . .

*The Type 158 Generator utilises a quill drive shaft and because of this, should only be run on test benches incorporating a direct shaft drive. On no account must a pulley be fitted to the quill shaft and driven by means of belts at right angles to the rotor axis.*

### Installation test

22. Using a 500 volt insulation tester, check the insulation resistance readings of the stator coils. These should not be less than 0.05 megohms. Using a 250 volt insulation tester, check the exciter windings insulation resistance. Minimum permissible reading 0.05 megohm. Alternatively a 500 volt insulation tester may be used to check the exciter insulation, but care must be taken to ensure that all the radio interference suppression condensers are disconnected before testing with the higher voltage tester.

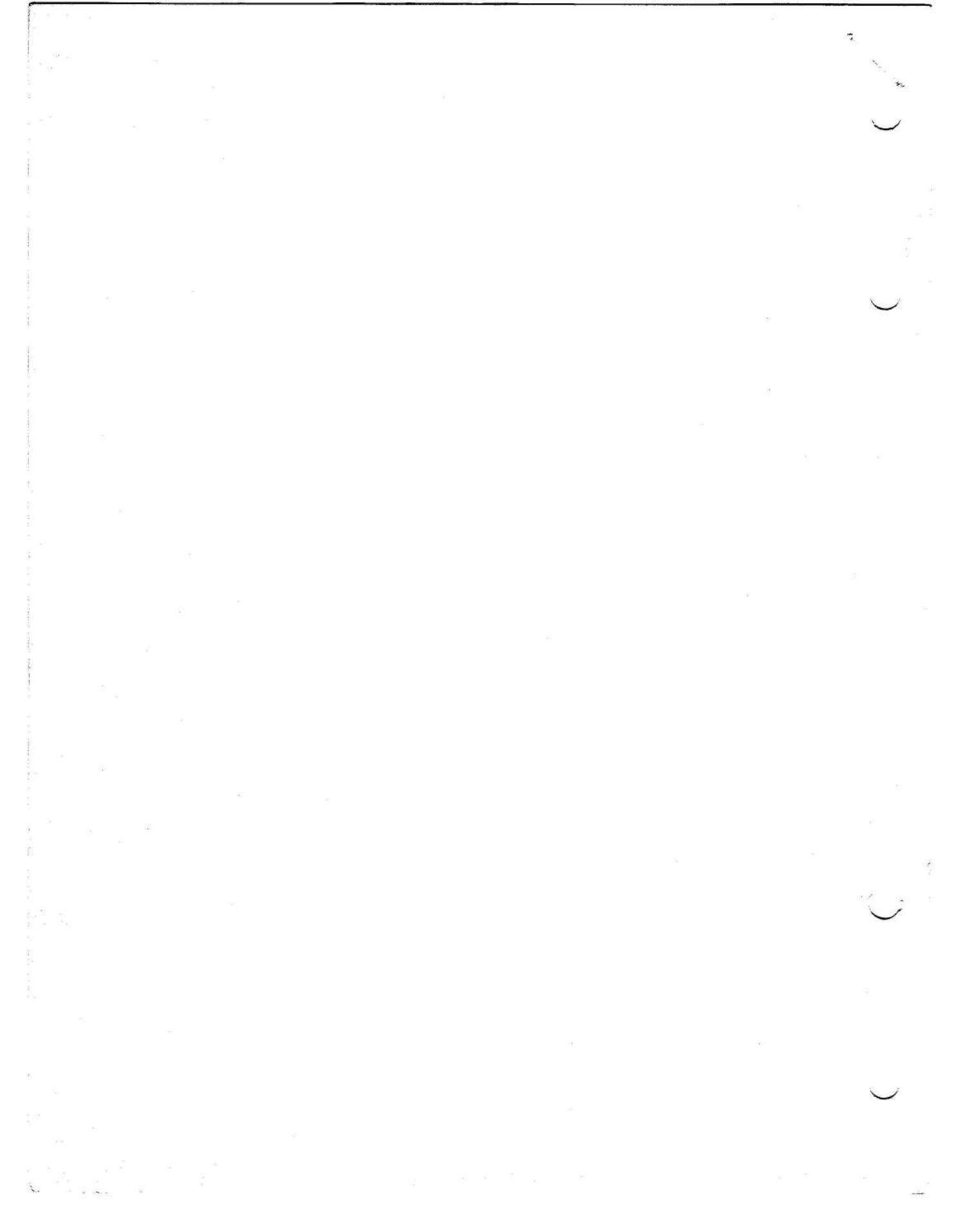

## Appendix 1

### A.C. GENERATORS, TYPE 158 VARIANTS

#### LIST OF CONTENTS

	Para.		Para.
<i>Introduction</i> .....	1	<i>Type 158B generator (AE.2023)</i> .....	4
<i>Type 158, Mk. 2 generator (AE.2039 Mk. 1)</i> .....	2	<i>Type 158C generator (AE.2044)</i> .....	5
<i>English Electric Types AE.2035 and AE.2038</i> .....	3	<i>English Electric types AE.2037, AE.2039 and AE.2041</i> .....	6

#### LIST OF ILLUSTRATIONS

	Fig.
<i>Variants of basic Type 158 generator</i>	1

#### Introduction

1. The Type 158 a.c. generator (*English Electric Type AE.918*) is the basic machine from which the various types depicted in fig. 1 have been developed.

#### Type 158, Mk. 2 generator (AE.2039, Mk. 1)

2.—This generator is basically a Type 158 (AE.918) which has been modified and fitted with the following components to suit the engine installation on which it is used.

- (1) Air pipe (AED.2039040)
- (2) Mounting flange (AED.2023061)
- (3) Quill shaft (AEC.2035048).

#### English Electric Types A.E.2035 and AE.2038

3. Both of these machines were developments of the basic AE.918 and have been used experimentally on prototype engines. They are superseded by the AE.2023 and will not be fitted to Service aircraft.

#### Type 158B generator (AE.2023)

4. The Type 158B generator is electrically identical with the Type 158 but has a manacle type mounting and also embodies a number of design improvements such as the fitting of stronger exciter brush-gear and a jacking type quill shaft. The latter enables the quill drive to be withdrawn from the constant speed drive before the generator is removed from its mounting, thus minimising the possibility of the drive being damaged.

#### Type 158C generator (AE.2044)

5. This generator is similar to the 158B but is flange mounted and has a smaller quill shaft to suit the Artouste A.A.P.P. with which it is used. The following items are fitted.

- (1) Quill shaft assembly (AEC.2041041)
- (2) Cover support ring assembly (AEC.2037018)
- (3) Air deflector (AEB.2039138).

**English Electric Types  
AE.2037, AE.2039 Mk. 2  
and AE.2041**

6. These three generators are also similar to the Type 158B but are fitted with the items shown below to suit the installations for which they are intended.

*AE.2037*

- (1) Mounting flange (2023061)
- (2) Quill shaft assembly (AEC.2023038)
- (3) Cover support ring assembly (2037018)
- (4) Air inlet pipe (AEG.2035036)
- (5) Cover plate (AEB.2037042).

*AE.2039, Mk. 2*

- (1) Mounting flange (AED.2023061)
- (2) Quill shaft assembly (AEC.2023038)
- (3) Cover support ring assembly (AEC.2037018)
- (4) Air intake (AED.2039137) and air deflector (AEB.2039138).

*AE.2041*

- (1) Cover support ring assembly (AEC.2037018)
- (2) Air outlet assembly (AED.2039140) and air intake (AEG.2042037). The quill shaft assembly, air deflector and cover support ring assembly are identical with those fitted to the Type 158C generator.

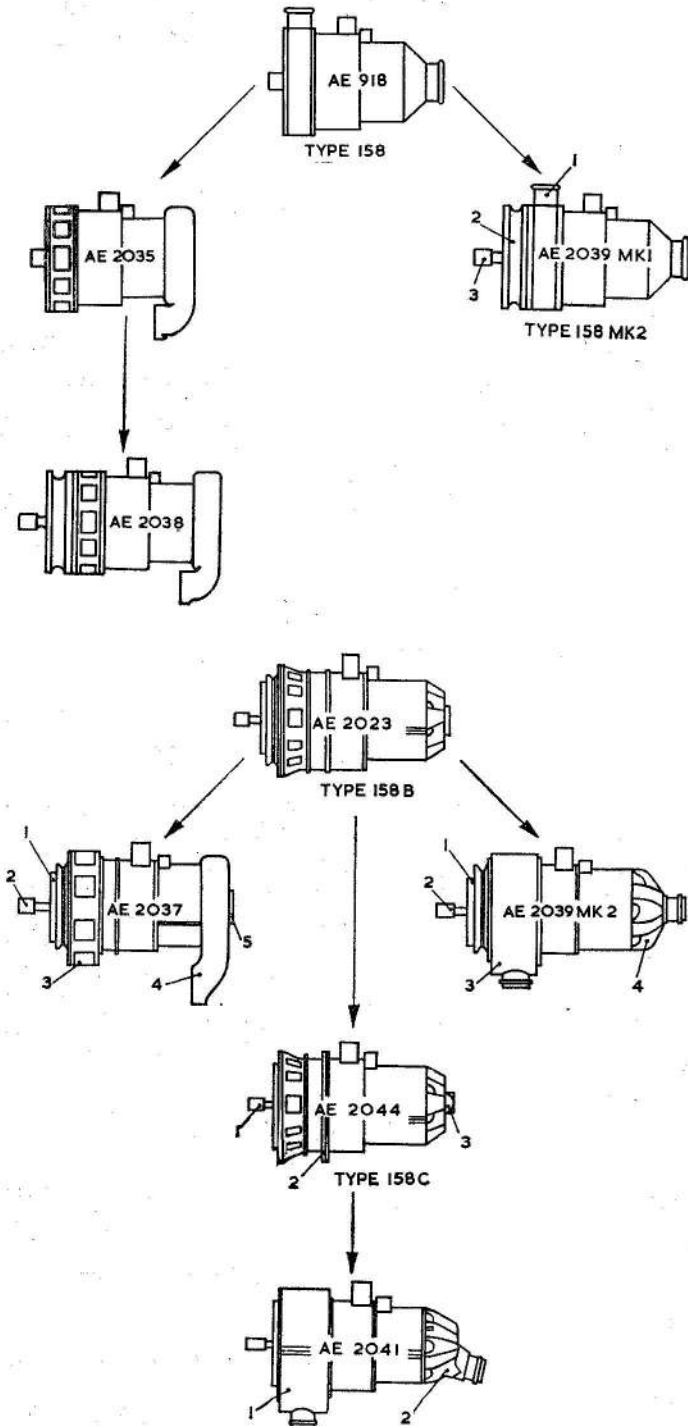

**Fig. 1. Variants of basic Type 158 generator**

**RESTRICTED**

This file was downloaded  
from the RTFM Library.

Link: [www.scottbouch.com/rtfm](http://www.scottbouch.com/rtfm)

Please see site for usage terms,  
and more aircraft documents.

