

Cancelled *Obsolete*

**Chapter 15**  
**GENERATORS, TYPE 512 SERIES**

**LIST OF CONTENTS**

|   | <i>Para.</i> |                                      | <i>Para.</i> |
|---|--------------|--------------------------------------|--------------|
| <i>Introduction</i> .. .. .             | 1            | <i>Internal connections</i> .. .. .  | 22           |
| <b>Description</b>                      |              | <b>Installation</b> .. .. .          | 24           |
| <i>General</i> .. .. .                  | 2            | <b>Operation</b> .. .. .             | 26           |
| <i>Cooling</i> .. .. .                  | 3            | <b>Servicing</b> .. .. .             |              |
| <i>Frame</i> .. .. .                    | 4            | <i>General</i> .. .. .               | 29           |
| <i>Commutator end—end plate</i> .. .. . | 6            | <i>Oil seal</i> .. .. .              | 31           |
| <i>Roller bearing</i> .. .. .           | 7            | <i>Brushes</i> .. .. .               | 35           |
| <i>Brush gear</i> .. .. .               | 8            | <i>Bedding</i> .. .. .               | 36           |
| <i>Springs</i> .. .. .                  | 11           | <i>Spring pressure</i> .. .. .       | 37           |
| <i>Drive end—end plate</i> .. .. .      | 14           | <i>Bearing lubrication</i> .. .. .   | 38           |
| <i>Bearing</i> .. .. .                  | 15           | <b>Tests</b>                         |              |
| <i>Cover plate</i> .. .. .              | 17           | <i>General</i> .. .. .               | 39           |
| <i>Armature</i> .. .. .                 | 18           | <i>Minimum-load test</i> .. .. .     | 41           |
| <i>Terminal box</i> .. .. .             | 19           | <i>Remagnetizing</i> .. .. .         | 46           |
| <b>Connections</b>                      |              | <i>Load test</i> .. .. .             | 47           |
| <i>Terminal connections</i> .. .. .     | 21           | <i>Insulation resistance</i> .. .. . | 48           |

**LIST OF ILLUSTRATIONS**

|   | <i>Fig.</i> |                                     | <i>Fig.</i> |
|---|-------------|-------------------------------------|-------------|
| <i>Exploded view of generator</i> .. .. . | 1           | <i>Circuit diagram</i> .. .. .      | 4           |
| <i>Brush spring assembly</i> .. .. .      | 2           | <i>Test circuit diagram</i> .. .. . | 5           |
| <i>Terminal connections</i> .. .. .       | 3           |                                     |             |

**LIST OF APPENDICES**

|                                     | <i>App.</i> |
|-------------------------------------|-------------|
| <i>Generator, Type 512</i> .. .. .  | 1           |
| <i>Generator, Type 512A</i> .. .. . | 2           |

STN/ELECT/GI Refers.

**Introduction**

1. The Type 512 series generators are engine driven through gearing and operate in conjunction with a voltage regulator Type 114 to provide a constant voltage supply over a wide range of engine speeds.

pensating windings; they are mounted on the aero-engine gearbox and have a serrated shaft drive. An exploded view of the type 512 generator is shown in fig. 1.

**DESCRIPTION**

**General**

2. The generators are six pole shunt wound machines embodying interpoles and com-f.s./1

**Cooling**

3. Blast cooling by air from the slipstream of the aircraft is employed. The air enters the body of the machine through one of the brush inspection windows, passes through the yoke, and leaves through a port in the

frame at the driving end. The union for the inlet air pipe is attached to a cover band encircling the commutator end of the frame, whilst the union for the outlet air pipe is mounted on a plate which is secured to the frame by four screws. Depending upon the arrangement of the air pipes in a particular aircraft installation, the outlet union is located over the most convenient port, the remaining ports being covered by blanking-off plates.

#### Frame

4. The rolled and welded steel frame houses the armature and carries the main poles and interpoles within the central yoke portion of its bore. The commutator-end and drive-end end-plates are attached to the ends of the frame, and the terminal box is mounted on its surface.

5. The main poles and interpoles are each secured by three bolts. The bolt heads are on the outer surface of the yoke, those for the main poles being partially let into the surface and locked by tab-washers.

#### Commutator-end end-plate

6. The commutator-end end-plate is a light alloy die-casting, secured to the end

of the frame by 12 bolts. It supports the brush gear and houses a roller bearing which is mounted on one end of the armature shaft.

#### Roller bearing

7. The outer race of the bearing is a push fit within a lined recess in the end-plate, and is held in position by a bearing cap secured to the end-plate by six screws. The inner race is a clearance fit on the armature shaft and is spaced from a step in the shaft by a sleeve. The extremity of the shaft is of reduced diameter and is threaded to take a bearing lock-nut which retains the inner race against the sleeve.

#### Brush gear

8. The brush gear is in the form of a cage comprising six brush boxes, each containing three brushes mounted between a pair of insulating end-rings. The boxes are spaced at equal intervals around the periphery of the commutator, and their ends are each secured by a pair of screws to the adjacent end-ring. Three screws in one end-ring secure the cage assembly to conical feet cast integral with a carrier ring which is located in an annular seating in the inner face of the commutator end-plate.

---

#### Key to Fig. 1

- |    |                       |    |                             |
|----|-----------------------|----|-----------------------------|
| 1  | CLAMPING RING         | 13 | DRIVING-END END-PLATE       |
| 2  | MOULDED BUSHING       | 14 | OUTER BEARING CAP           |
| 3  | GROMMET               | 15 | BALL BEARING                |
| 4  | TERMINAL BOX          | 16 | ARMATURE                    |
| 5  | CAPACITORS AND CLAMPS | 17 | AIR OUTLET UNION            |
| 6  | STRAP CONNECTORS      | 18 | COVER BAND                  |
| 7  | INNER BEARING CAP     | 19 | BRUSH GEAR                  |
| 8  | SLEEVE                | 20 | COMMUTATOR-END END-PLATE    |
| 9  | CLAMPING NUT          | 21 | BEARING CAP                 |
| 10 | CIRCLIP               | 22 | ROLLER BEARING              |
| 11 | OIL SEAL              | 23 | TERMINAL MOULDING           |
| 12 | OIL SEAL HOUSING      | 24 | OUTPUT CABLE LUG            |
|    |                       | 25 | EQUALISING CONNECTION GLAND |

**RESTRICTED**

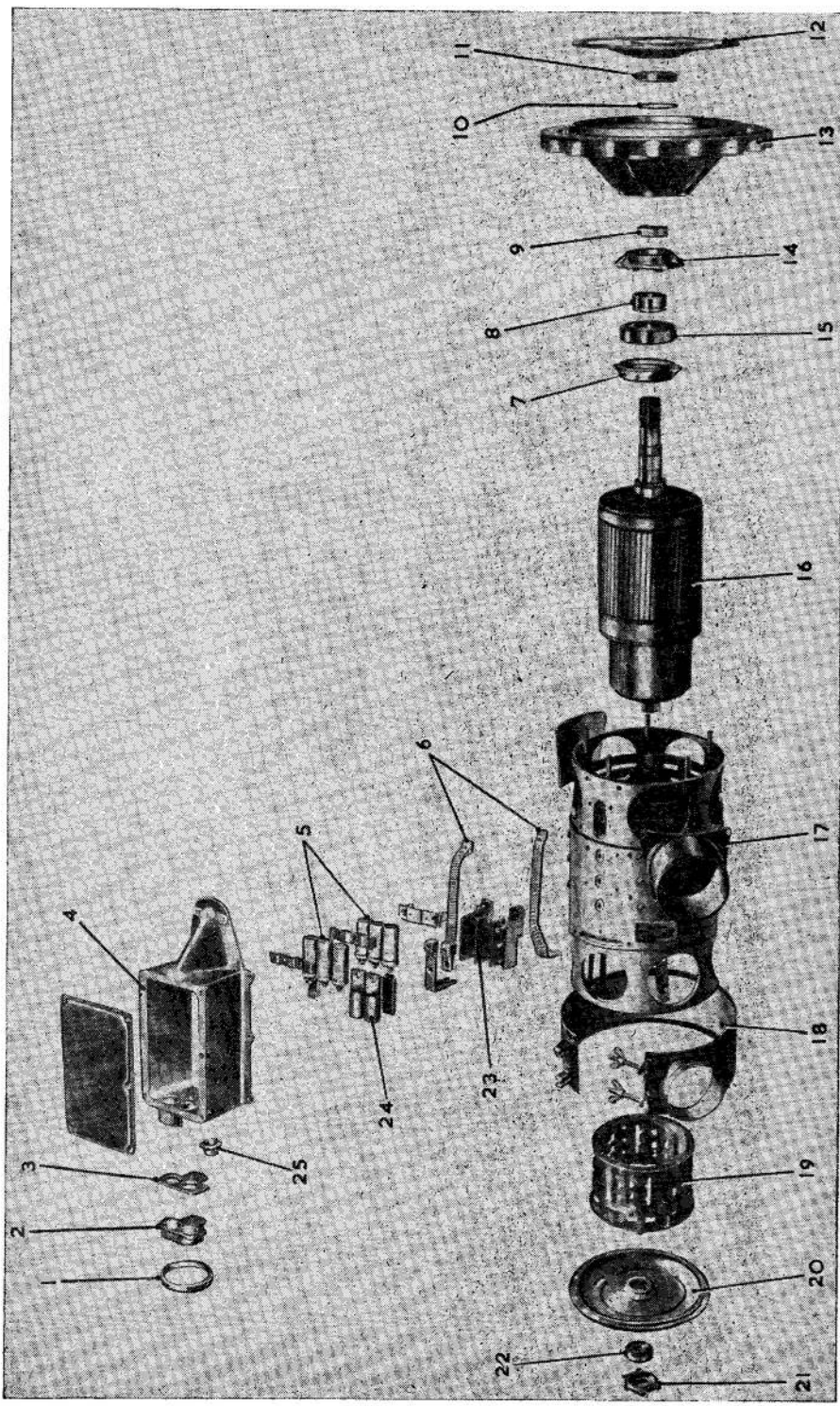

Fig. 1. Exploded view of Generator

9. The carrier ring is provided with three hexagonally recessed bosses, interspaced between the projecting feet. These bosses are drilled to accept bolts for attaching the brush gear assembly to the commutator end-plate. The bolts protrude through slots in the end-plate and are secured on the outer side by stiff-nuts.

10. The slots permit a degree of adjustment of the brush gear, so that the brushes may be rocked into the magnetic neutral plane. A small pointer is secured beneath one of the stiff-nuts, and the correct location of the brush gear is indicated by the position of this pointer in relation to a white engraving "NP" on the end plate.

#### *Springs*

11. The brush spring assembly (*fig. 2*) for each brush box consists of three coiled strip springs mounted on a spindle which is supported in holes in the insulating end rings. The springs are spaced by sleeves and their captive ends engage in a slot in the spindle.

12. One end of the spindle protrudes through the end-ring to which the carrier ring is attached. Mounted on the spindle, between this end-ring and the first ring, is a hexagonal nut. This nut is secured by a split pin and serves to retain the assembly in position between the end-rings, and also provides a means of adjusting the spring pressure.

13. Another hexagonal nut and a tab-washer are mounted on the protruding end of the spindle. The nut is attached to the spindle by a pin which passes through a second slot in the spindle, and is retained on the spindle by a split pin inserted in the spindle itself at right angles to the slot. This retaining nut is prevented from rotating by the tab-washer, and serves to retain the springs at a given pressure.

#### **Drive-end end-plate**

14. The drive-end end-plate is mounted on five studs projecting from the end of the frame. The bushed hole in the boss of the casting contains an enclosed ball bearing which supports the driving end of the armature shaft.

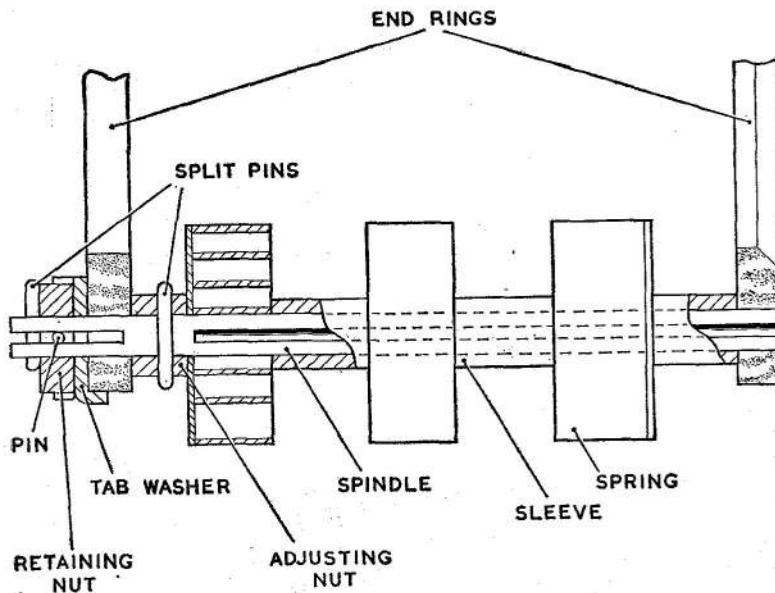

**Fig. 2. Brush spring assembly**

**RESTRICTED**

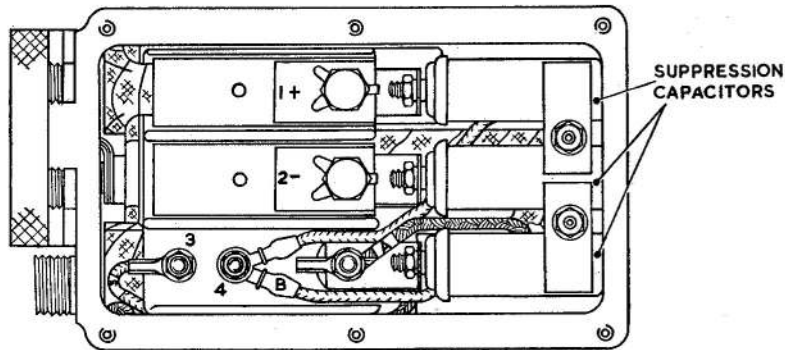

Fig. 3. Terminal connections

#### Bearing

15. The bearing, which is a push fit within the bush, is held between outer and inner bearing caps. The inner cap is secured by six 2 B.A. ch/hd. screws. Three of these screws are  $1\frac{1}{2}$  in. long and pass through the lip of the bush and the boss of the casting, whilst the other three are  $1\frac{1}{4}$  in. long and additionally pass through the outer bearing cap.

16. The bearing is a clearance fit on the armature shaft and is held against a step in the shaft by a sleeve which is retained in position by a clamping nut. A portion of the shaft is threaded to take this nut, which is locked by a circlip.

#### Cover plate

17. The bearing assembly is enclosed by a die-cast cover plate secured to the five studs upon which the drive-end end-plate is mounted. The cover plate locates an oil seal around the armature shaft, by which means oil from the engine gearbox is prevented from entering the bearing and diluting the grease. The oil seal is retained within its recess in the cover plate by a circlip.

#### Armature

18. The armature lies within the frame, the machined shaft ends being supported in the bearings. The serrated end of the shaft protrudes through the cover plate

F.S./3

at the driving end to connect to the engine gearbox. The hollow centre portion of the shaft carries the armature stampings and the commutator. The 60-slot armature is lap-wound and is fitted with equalizing rings. The stainless steel binding wire and all connections to the 120-bar commutator are secured by brazing. During manufacture, the complete armature is balanced by screwing small balancing strips to the stampings at the driving end as required. In addition there may be brazing on the binding wire at the commutator end.

#### Terminal box

19. The terminal box casting is provided with eight fixing holes to accept screws for attaching to the frame. The cable entry is at the commutator end, where four holes are drilled to take the cables. The output and field leads pass through a moulded bushing which is secured within a gland by a knurled clamping ring. A separate gland is provided for the equalizing connection. The terminal box is provided with a top cover, secured by six screws.

20. The contents of the terminal box are mounted on the frame of the machine. The terminals are located in insulating mouldings which also secure the taped strap connectors. These connectors pass through slots cut in the frame to connect the machine windings. The terminal box also houses six interference suppression capacitors which are secured by spring clamps.

RESTRICTED

## CONNECTIONS

### Terminal connections

21. The terminal connections are shown in fig. 4. Terminals No. 1 and No. 2 are the positive and negative generator output terminals respectively, and No. 4 is the field terminal. The equalizing connection (para. 27) is made to terminal No. 3.

### Internal connections

22. The circuit diagram of the generator is shown in fig. 4. The Resistor R, is composed of two parallel-connected rings of resistance strip. These are secured on insulating mountings within the bore of the frame at the driving end. The total resistance of the rings and the compensating windings is approximately 0.007 ohms. This value of resistance ensures that a voltage difference, the value of which depends upon the load current, exists between terminals No. 3 and No. 2.

23. There is one connecting lead to each brush box. The terminal tag is attached to the box by the screw which also secures the pigtail tag of the brush lying nearest to the commutator-end end-plate.

## INSTALLATION

24. Before installing the generator, ensure that the direction of rotation, as marked on the small plate riveted to the frame, is suitable for the engine gearbox. Remove the protecting ferrule from the shaft and examine the serrations for damage. Ensure that an oil seal is fitted.

25. Mount the generator on the engine gearbox and secure the bolts. Connect the cables to the terminals and secure the terminal box cover. Attach the air pipes. Reference should be made to A.P.4343, Vol. 1, Sect. 2, Chap. 1 for information on the care of, and anti-corrosive treatment for these pipes.

## OPERATION

26. The generator will normally form part of an aircraft supply system, comprising two or more generators, each driven by a separate engine and feeding a common busbar. The power system incorporates voltage regulating circuits, each generator working in conjunction with a Type 114 voltage regulator. By this means, the generator output voltage is maintained at a value of

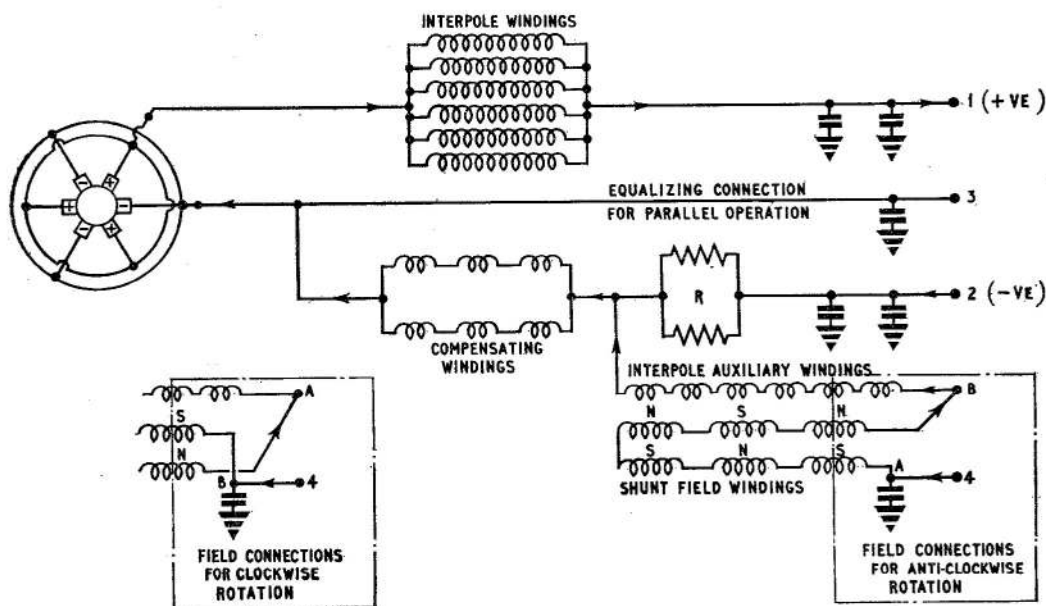

Fig. 4. Circuit diagram

RESTRICTED

28 volts ( $\pm 2.5$  per cent) at all loads up to its rated maximum, and over a speed range of 2,850-10,000 r.p.m.

27. To ensure that the total load of the system is shared equally between all the generators, an equalizing circuit is employed. The voltage appearing at terminal No. 3 of the generator (fig. 5) is proportional to the load, and an equalizing connection is made from this terminal to the voltage regulator. Full details of the system may be obtained from A.P.4343, Vol. 1, Sect. 2, Chap. 5.

## SERVICING

### General

28. Information on servicing, common to all d.c. generators, is to be found in A.P. 4343, Vol. 1, Sect. 2, Chap. 1. The following paragraphs should be read in conjunction with that chapter and with the relevant Servicing Schedule.

29. To examine the machine, the air pipes should be disconnected and the commutator end cover band removed. The terminal box cover and the blanking-off plates at the driving end of the frame should also be removed.

30. Clean and examine the frame, commutator, and brush gear, ensuring that all nuts, bolts, screws and locking devices are secure. Check the insulation of all connecting leads and straps for damage or deterioration and ensure that the connections are tight. When replacing the cover band examine it for distortion and renew if necessary.

### ◀Note . . .

*When tightening the terminal connections and bearing locknuts the following values of torque should be applied:*

- (1) *The terminal box busbar bolts and 4BA nuts should be tightened to a maximum torque of 60 lb. in. and 14 lb. in. respectively.*
- (2) *The commutator-end and drive-end bearing locknuts should be tightened to a maximum torque of 60 lb. in. and 240 lb. in. respectively.▶*

### Oil seal

31. If the machine is to be run on the test bench, either for brush bedding purposes or for testing, the oil seal must first be removed, since under these conditions the seal is not adequately lubricated. Under normal conditions the seal is in contact with the oil in the engine gearbox.

32. When the oil seal is to be removed, the serrations on the armature shaft should first be covered with tape, transparent, waterproof, colourless, adhesive (Ref. No. 32B/997). The tape should be wound on commencing at the extremity of the shaft. The layer of tape prevents the seal being damaged when drawn over the serrations.

33. The procedure for removing the seal is then as follows:

- (1) Remove the five  $\frac{1}{4}$  in. B.S.F. hex/hd. nuts securing the cover plate to the studs projecting through the drive-end end-plate.
- (2) Insert 4 B.A. screws of suitable length into one or other of the pair of tapped holes adjacent to each stud.
- (3) Evenly screw in these five screws to ease the cover plate clear of the register in the end-plate.
- (4) When the fingers can be inserted into the gap, carefully withdraw the cover plate over the serrations and off the shaft.
- (5) Remove the retaining circlip and press the seal out of its recess in the cover plate.
- (6) Replace the cover plate and secure to the studs before running the machine.

### Note . . .

*The studs are unevenly spaced around the end of the frame, and will only accept the cover plate when offered the correct way.*

34. To fit the oil seal, it should be pressed into its recess in such a way that, when on the machine, the coiled spring band inserted in the seal is visible from the driving end.

RESTRICTED

Before mounting the cover plate on the shaft, the serrations should be re-wound with tape, but this time commencing from the bearing side. In addition, the armature shaft should be lightly greased. A new set of tab-washers should be obtained, and, when the cover plate nuts are tightened, the tabs should be punched into one or other of the tapped holes adjacent to each stud.

### Brushes

**35.** Brush grades and minimum lengths are given in the Appendices to this chapter, which contain Leading Particulars for each generator in the series. If brushes are removed care should be taken to see that they are replaced the same way round. Brushes should be renewed at periods prescribed in the relevant Servicing Schedule, and whenever examination reveals that they will not remain serviceable for the period that will elapse before the next servicing.

### Bedding

**36.** When new brushes are fitted they must be bedded on the commutator for their full thickness over at least 80 per cent of their axial width. Bedding should be carried out by running the machine as a motor on the bench with 15V, d.c. applied to the output terminals. The positive and negative supply leads must be connected to machine terminals No. 1 and No. 2 respectively. A separate 3V d.c. supply should be connected across the field connections A and B (fig. 4), the polarity of which is determined by the direction of rotation of the generator. For clockwise machines, the connections are positive to lead B and negative to lead A, the polarity should be reversed for counter-clockwise machines. Under these conditions the current in the armature and field will be about 25 amp. and 3 amp. respectively. The machine will run at a speed between 2,500 and 3,000 r.p.m. Ensure that the oil seal is removed before running.

### Note . . .

*Throughout the bedding run, the generator must be cooled by an air blower, Type A (Ref. No. 5A/1901 or 5A/1902).*

### Spring pressure

**37.** The pressure of each brush spring should be checked to ensure that it lies

between 18 oz. and 22 oz. The measurement may conveniently be carried out if a small length of wire, hooked to engage in the loop on the brush spring where it bears on the brush, is attached to a suitable pull-type spring balance.

### Bearing lubrication

**38.** The bearings should be inspected at the periods specified in the appropriate servicing schedule, they should be thoroughly cleaned and all traces of old lubricant removed from the bearing caps. The bearings and caps should be lubricated as follows:

Drive-end—Apply 2 drams of grease XG-271 (Ref. No. 34B/9100510), by filling the bearing three-quarters full, and a further 2 drams by filling the cavity of the bearing cap.

Commutator-end—Apply  $1\frac{1}{4}$  drams of grease XG-271 by filling the bearing three-quarters full, and a further  $2\frac{1}{2}$  drams by filling the cavity of the bearing cap.

## TESTS

### General

**39.** A new or reconditioned generator should be tested as described in the following paragraphs before installation. If an oil seal is fitted to the generator it must be removed before the tests are begun.

**40.** The armature should first be turned by hand to ensure that it does not foul any leads or fixed parts of the machine. Rotation should be smooth, and the end-play in the bearings should not be excessive. Slight radial play which can just be felt by hand is permissible. The machine should also be observed for undue vibration during the following running tests.

### Minimum-load test

**41.** A Type 114 voltage regulator, which has previously been tested for correct operation, should be used in conjunction with the generator for this test. Reference may be made to A.P.4343B, Vol. 1, Sect. 1, Chap. 41 for details of this regulator.

**42.** The tests should be carried out with the generator mounted on the generator test bench and connected as shown in the test circuit diagram (fig. 5). An external trimmer resistor is connected between terminals

No. 1 and No. 4 of the voltage regulator. The voltmeter  $V_1$  on the d.c. panel of the testing set should be switched to the 0-40 volt range. This voltmeter will record the voltage across terminals G+ and G-, i.e. the regulated terminal voltage of the generator. A suitable millivoltmeter  $V_2$  is connected across terminals No. 2 and No. 3 of the generator, with its polarity as shown

in the diagram. Before commencing the test, the fixed load resistor in the testing set should be switched out and the variable load rheostat adjusted to the minimum-load position.

**43.** Run the generator in the correct direction of rotation at a speed of 2,850 r.p.m., and observe the readings of meters,

(Continued on next leaf)

**RESTRICTED**

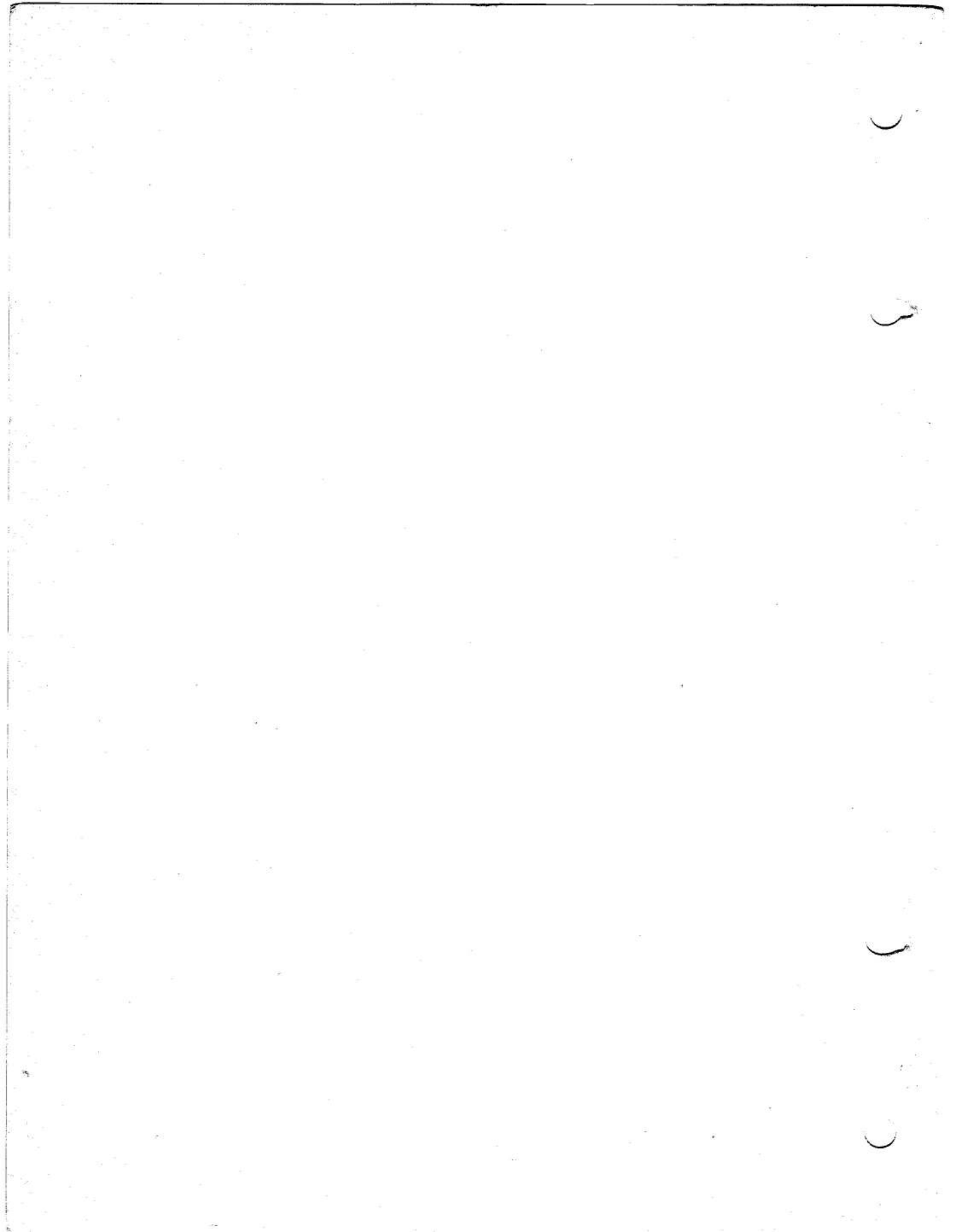

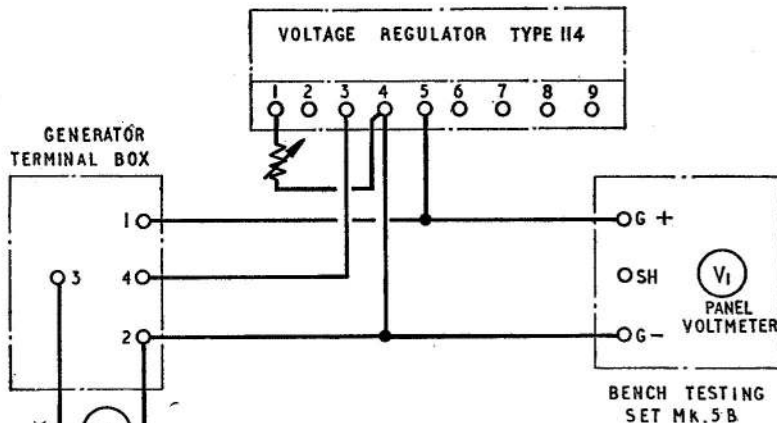

Fig. 5. Test circuit diagram

$V_1$  and  $V_2$ . If the polarity of the generator is correct, positive readings will be obtained as the voltage builds up.

44. The terminal voltage of the generator (voltmeter  $V_1$ ) should build up without hesitation to between 27.5 and 28.5 volts. The millivoltmeter  $V_2$  should give a positive reading.

45. If positive readings are not obtained, check all connections and ensure that the direction of rotation is correct. Should the polarity prove to be incorrect, or the generator fail to build up, the poles must be remagnetized.

#### Remagnetizing

48. To re-magnetize the poles, disconnect the test circuit and connect a 6-volt battery in series with a single-pole quick-break switch across the generator field terminals. The positive battery lead must be connected to the generator terminal No. 4, and the negative lead to terminal No. 2 on the generator. Using the switch, make and break the circuit once only to magnetize the poles. Repeat the test in para. 42-45 to ensure that the machine has been correctly magnetized.

#### Note . . .

*Unless an air blower is used, the machine must not be driven continuously for longer than 10 min. Allow the machine to cool down to room temperature before re-starting.*

#### Load test

47. For this test, the voltage regulator is F.S./5

replaced by a resistance of 0.74 ohms, connected between generator terminals No. 1 and No. 4, and millivoltmeter  $V_2$  disconnected. This value of resistance corresponds to the minimum value of regulator resistance. Starting with the generator at room temperature, and taking readings on the test bench meters, run the generator for a period of 2.5 min. at an output of 200 amp. at 28 volts, maintaining this output constant by adjusting the generator speed. At the end of the period, ensure that the speed does not exceed 2,500 r.p.m. Also check that there is no more than pin-point sparking at the brushes.

#### Note . . .

*The generator is deprived of its normal flow of cooling air when run on the test bench. It is important, therefore, to ensure that the 2.5 min. running period is not exceeded. Otherwise over-heating will occur with possible damage to the machine.*

#### Insulation resistance

48. The insulation resistance measured between the generator terminals and the frame whilst the machine is still hot after the load tests, should not be less than 50,000 ohms using a 250-volt insulation resistance tester. If a lower resistance is obtained, the interference suppression capacitor should be disconnected and checked for serviceability. Care must be taken to avoid breaking the spring clamp when renewing defective capacitors.



## Appendix 1

### GENERATOR TYPE 512

#### LEADING PARTICULARS

|                                    |    |    |    |    |    |    |    |    |   |
|------------------------------------|----|----|----|----|----|----|----|----|---|
| <b>Generator, Type 512</b>         | .. | .. | .. | .. | .. | .. | .. | .. | Ref. No. 5UA/5833                           |
| <i>Rotation</i>                    | .. | .. | .. | .. | .. | .. | .. | .. | <i>clockwise (from driving end)</i>         |
| <b>Generator, Type 512</b>         | .. | .. | .. | .. | .. | .. | .. | .. | Ref. No. 5UA/6005                           |
| <i>Rotation</i>                    | .. | .. | .. | .. | .. | .. | .. | .. | <i>counter clockwise (from driving end)</i> |
| <i>Rated output</i>                | .. | .. | .. | .. | .. | .. | .. | .. | 9kW   |
| <i>Rated voltage</i>               | .. | .. | .. | .. | .. | .. | .. | .. | 30V d.c.                                    |
| <i>Speed range</i>                 | .. | .. | .. | .. | .. | .. | .. | .. | 2,850-10,000 r.p.m.                         |
| <b>Voltage regulator, Type 114</b> | .. | .. | .. | .. | .. | .. | .. | .. | Ref. No. 5UC/6360                           |
| <i>Regulated voltage</i>           | .. | .. | .. | .. | .. | .. | .. | .. | 28V   |
| <b>Brushes—</b>                    |    |    |    |    |    |    |    |    |   |
| <i>Grade</i>                       | .. | .. | .. | .. | .. | .. | .. | .. | P.E.G. 11                                   |
| <i>Length (absolute minimum)</i>   | .. | .. | .. | .. | .. | .. | .. | .. | 0.5 in. on shortest side                    |
| <i>Spring pressure</i>             | .. | .. | .. | .. | .. | .. | .. | .. | 18-22 oz.                                   |
| <i>Min. commutator diameter</i>    | .. | .. | .. | .. | .. | .. | .. | .. | 3.97 in.                                    |
| <b>Weight</b>                      | .. | .. | .. | .. | .. | .. | .. | .. | 82.5 lb.                                    |

1. A full description, with details of servicing and testing the Generator Type 512 is given in Chapter 15. The generator is flange mounted by a sixteen hole flange

formed on the outside of the drive-end end-plate. This method of coupling differs from others in the series.

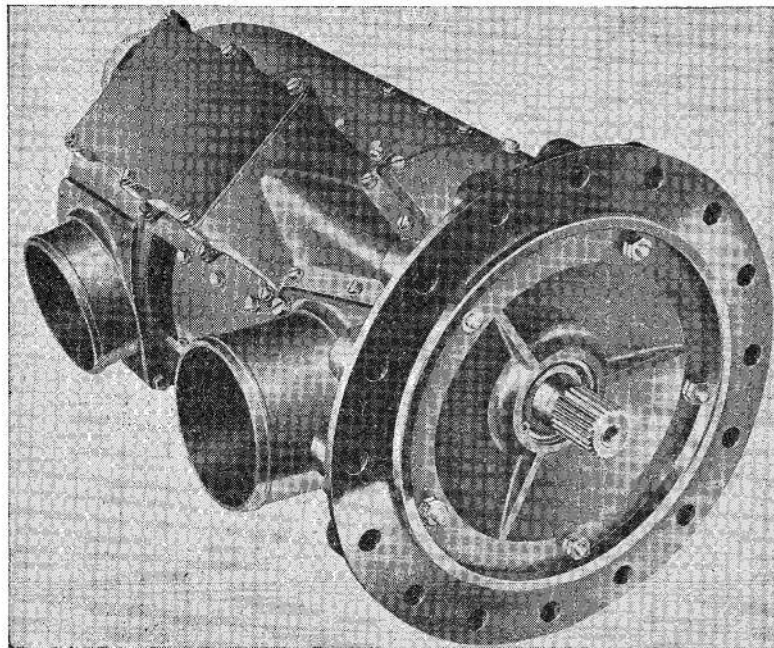
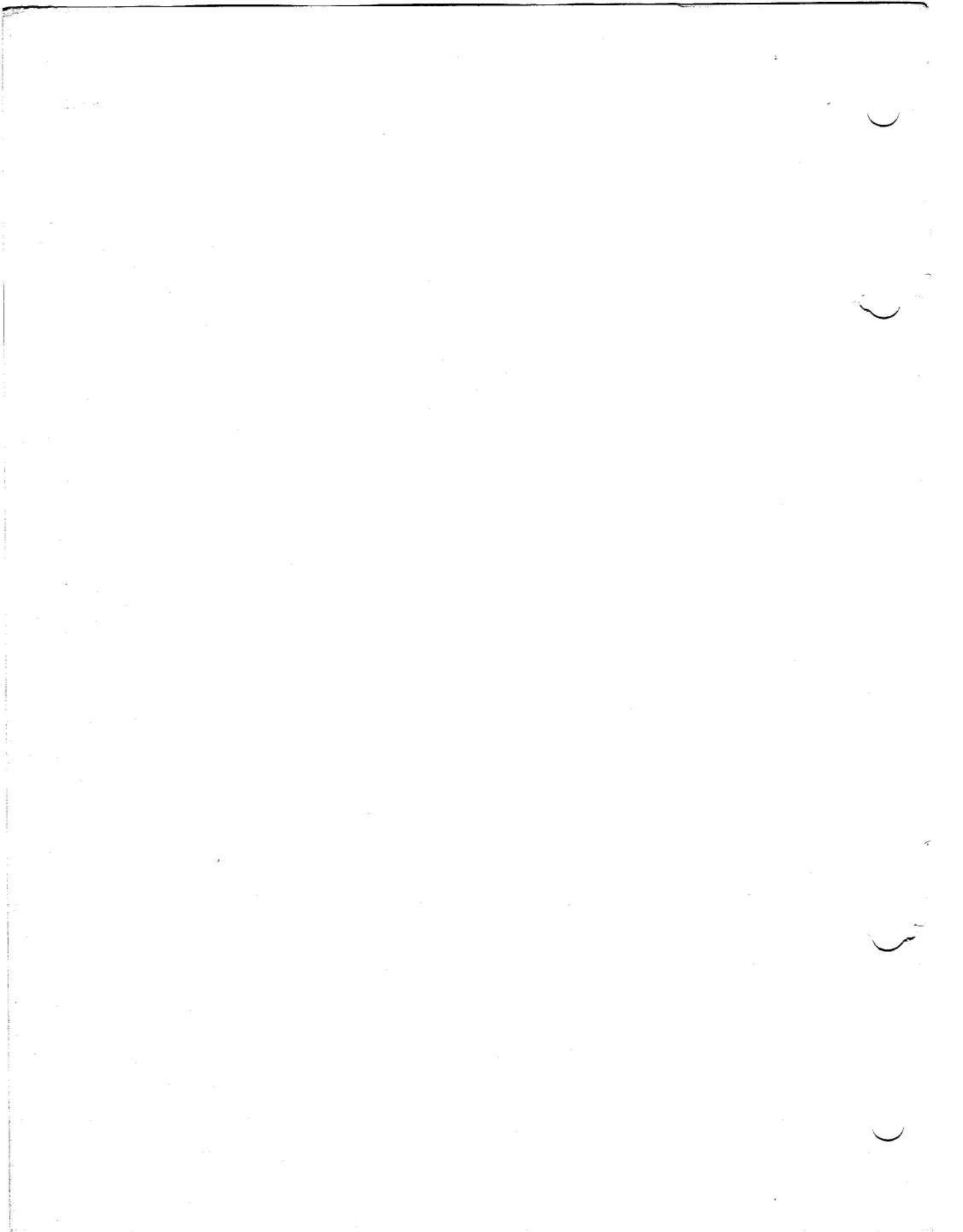

Fig. 1. Generator Type 512

**RESTRICTED**



## Appendix 2

### GENERATOR TYPE 512A

#### LEADING PARTICULARS

|                                    |    |    |    |    |    |    |    |    |                                     |
|------------------------------------|----|----|----|----|----|----|----|----|-------------------------------------|
| <b>Generator, Type 512A</b>        | .. | .. | .. | .. | .. | .. | .. | .. | Ref. No. 5UA/6352                   |
| <i>Rotation</i>                    | .. | .. | .. | .. | .. | .. | .. | .. | <i>clockwise (from driving end)</i> |
| <i>Rated output</i>                | .. | .. | .. | .. | .. | .. | .. | .. | 9kW                                 |
| <i>Rated voltage</i>               | .. | .. | .. | .. | .. | .. | .. | .. | 30V d.c.                            |
| <i>Speed range</i>                 | .. | .. | .. | .. | .. | .. | .. | .. | 2,850-10,000 r.p.m.                 |
| <b>Voltage regulator, Type 114</b> | .. | .. | .. | .. | .. | .. | .. | .. | Ref. No. 5UC/6360                   |
| <i>Regulated voltage</i>           | .. | .. | .. | .. | .. | .. | .. | .. | 28V                                 |
| <b>Brushes—</b>                    |    |    |    |    |    |    |    |    |                                     |
| <i>Grade</i>                       | .. | .. | .. | .. | .. | .. | .. | .. | P.E.G. 11                           |
| <i>Length (absolute minimum)</i>   | .. | .. | .. | .. | .. | .. | .. | .. | 0.5 in. on shortest side            |
| <i>Spring pressure</i>             | .. | .. | .. | .. | .. | .. | .. | .. | 18-22 oz.                           |
| <i>Min. commutator diameter</i>    | .. | .. | .. | .. | .. | .. | .. | .. | 3.97 in.                            |
| <i>Weight</i>                      | .. | .. | .. | .. | .. | .. | .. | .. | 82.5 lb.                            |

1. A full description, with details of servicing and testing the Generator Type 512A is given in Chapter 15. This generator is electrically identical to the Type 512,

it differs only in the construction of the drive-end end-plate which is designed to be manacle mounted on the engine gearbox.

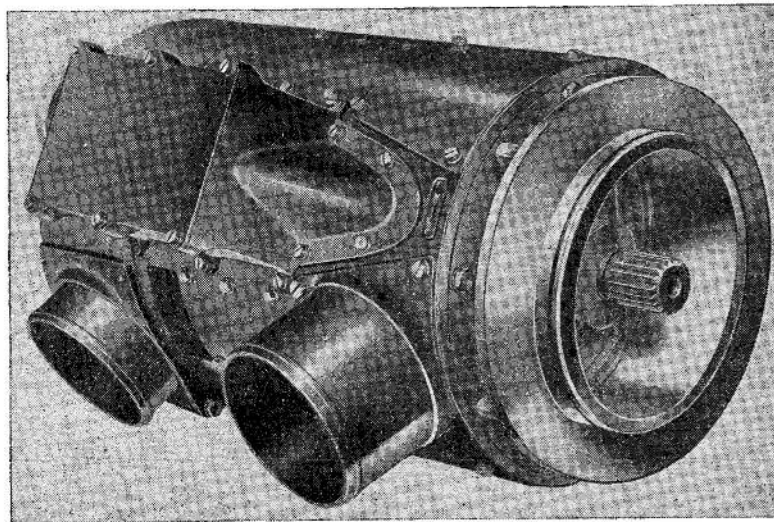

Fig. 1. Generator Type 512A

**RESTRICTED**

100

5

2

2

This file was downloaded  
from the RTFM Library.

Link: [www.scottbouch.com/rtfm](http://www.scottbouch.com/rtfm)

Please see site for usage terms,  
and more aircraft documents.

