

Chapter 20

GENERATOR TYPE 514. (E.E. TYPE AE 2505)

LIST OF CONTENTS

	<i>Para.</i>		<i>Para.</i>
<i>Introduction</i> ... ..	1	<i>Oil seal</i> ... ..	11
<b>Description</b>		<i>Cooling</i> ... ..	12
<i>General</i> ... ..	2	<i>Terminal box</i> ... ..	13
<i>Frame</i> ... ..	3	<b>Servicing</b>	
<i>Commutator end, endplate</i> ... ..	4	<i>General</i> ... ..	14
<i>Roller bearing</i> ... ..	5	<i>Brushes</i> ... ..	15
<i>Armature</i> ... ..	6	<i>Brush bedding</i> ... ..	16
<i>Field windings</i> ... ..	7	<i>Lubrication</i> ... ..	17
<i>Brushgear</i> ... ..	8	<b>Testing</b>	
<i>Drive end, endplate</i> ... ..	9	<i>No load test</i> ... ..	18
<i>Ball bearing</i> ... ..	10	<i>Insulation test</i> ... ..	19

LIST OF ILLUSTRATIONS

	<i>Fig.</i>
<i>Generator, type 514</i> ... ..	1
<i>Sectioned view</i> ... ..	2
<i>View of terminal box with cover</i>	
<i>removed</i> ... ..	3
<i>Internal wiring</i> ... ..	4
<i>Test circuit</i> ... ..	5

## LEADING PARTICULARS

Generator, type 514	...	...	...	...	...	...	...	...	...	...	...	...	...	...	...	Ref.No. 5UA/6384
Voltage	...	...	...	...	...	...	...	...	...	...	...	...	...	...	...	30 V.
Current	...	...	...	...	...	...	...	...	...	...	...	...	...	...	...	400 A
Rotation	...	...	...	...	...	...	...	...	...	...	...	...	...	...	...	Counter clockwise
Speed range	...	...	...	...	...	...	...	...	...	...	...	...	...	...	...	2850-8550 r.p.m.
Rating	...	...	...	...	...	...	...	...	...	...	...	...	...	...	...	Continuous
Cooling	...	...	...	...	...	...	...	...	...	...	...	...	...	...	...	Blast Air
Voltage regulator	...	...	...	...	...	...	...	...	...	...	...	...	...	...	...	Type 111 (Ref.No. 5UC/6289)
Regulated voltage	...	...	...	...	...	...	...	...	...	...	...	...	...	...	...	28 V. $\pm$ 2.5. per cent.
Brush grade	...	...	...	...	...	...	...	...	...	...	...	...	...	...	...	P.E.G. II.
Brush spring pressure	...	...	...	...	...	...	...	...	...	...	...	...	...	...	...	49½ - 55 oz.
New brush length	...	...	...	...	...	...	...	...	...	...	...	...	...	...	...	1 3/8 in. (on longest side)
Minimum brush length	...	...	...	...	...	...	...	...	...	...	...	...	...	...	...	0.925 in.
Minimum commutator diameter	...	...	...	...	...	...	...	...	...	...	...	...	...	...	...	3.94 in.
Commutator undercut	...	...	...	...	...	...	...	...	...	...	...	...	...	...	...	1/32 in.
Dimensions																
Length overall	...	...	...	...	...	...	...	...	...	...	...	...	...	...	...	17.3 in.
Height overall	...	...	...	...	...	...	...	...	...	...	...	...	...	...	...	14.375 in.
Width overall	...	...	...	...	...	...	...	...	...	...	...	...	...	...	...	9.750 in.
Weight	...	...	...	...	...	...	...	...	...	...	...	...	...	...	...	118.5 lb.

### Introduction

1. The generator Type 514 (*fig.1*) is a 12 kW d.c. machine designed to supply power over a wide range of speeds as quoted in the leading particulars.

### DESCRIPTION

#### General

2. The generator is a 4 pole, shunt wound machine with interpoles and compensating windings to provide good commutation under varying conditions of load and speed. The armature is retrogressive wave wound and is supported on ball and roller bearings at the drive end and commutator end respectively. The generator mounting is a manacle type flange.

#### Frame

3. The ferrous frame is rolled and welded to provide a mounting for the main poles and interpoles within the central yoke portion of its bore. The terminal box housing for the main output terminals is mounted on top of the frame. Two lifting lugs are welded to the frame to facilitate lifting and installation of the machine.

#### Commutator end, endplate

4. The endplate is a light alloy forging which houses the roller bearing and supports the brush rocker. The brush rocker is located in slotted holes to provide adjustment of the neutral position. The endplate is attached to the frame by fifteen 2 B.A. hexagon head bolts which are locked by

RESTRICTED

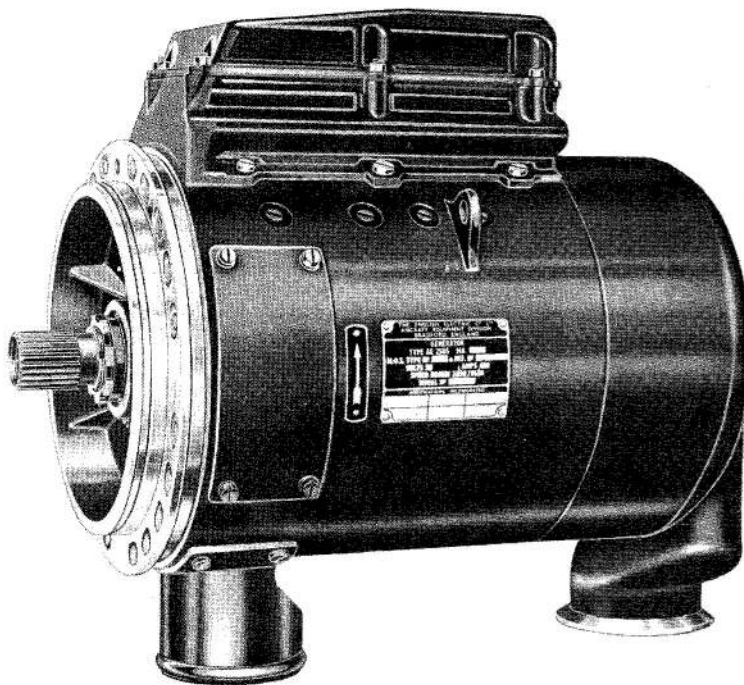

Fig.1 Generator, type 514

tabwashers. The blast air entry pipe housing is attached to the endplate by clamp type fittings which locate in an annular groove. This allows the position of the air inlet pipe to be infinitely variable to suit alternative installations.

#### Roller bearing

5. The roller bearing at the commutator end has a flanged type outer race which abuts directly onto the endplate. It is retained in position by four 2 B.A. studs which pass through the flanged outer race and bearing cap. The inner race of the bearing is retained on the shaft by a bearing lock bolt which mates with an internal thread cut in the end of the armature shaft. The bearing lock bolt is retained in position by

a cup washer which is locked into one slot of the bolt head.

#### Armature

6. The armature is retrogressive wave wound, the windings being connected to a 35 segment commutator. The drive end of the shaft is machined to provide a splined end for driving purposes.

#### Field windings

7. The field windings consists of a main shunt winding, compensating winding and interpoles. A ferry (nickel copper alloy) resistance ring is fitted at the drive end of the machine, this is connected in the main negative lead and is used in the equalising circuit for parallel operation. (A.P.4343,

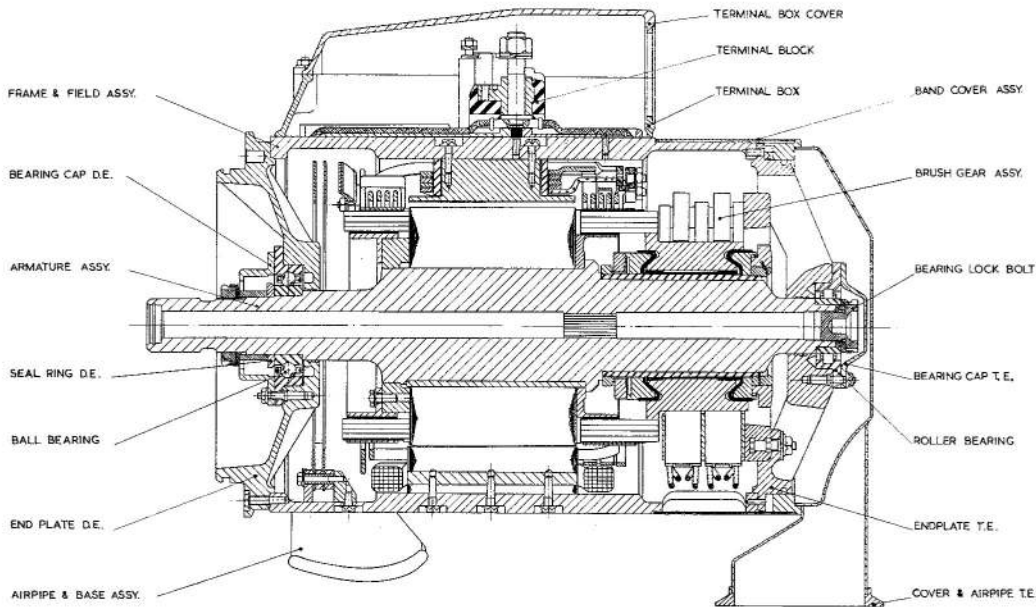

Fig.2 Sectional view

Vol.1, Sect.2) refers.

#### Brushgear

8. The brushgear consists of a moulded brush rocker on which four brush box assemblies are mounted. Each brush box houses two pairs of split brushes; brush spring pressure is provided by a single flat coiled spring for each pair of split brushes. The brush spring pressure is adjusted by rotating the spring adjusters.

#### Drive end, endplate

9. The endplate is a light alloy forging incorporating a manacle type mounting flange. The endplate incorporates an integral grease seal which is machined on the inner edge of the bore.

#### Ball bearing

10. A flanged ball bearing is fitted to the shaft. The bearing is retained in position by six 2 B.A. studs which pass through the flanged outer race and bearing cap. These

components are then secured by nuts and tabwashers. A hardened steel sealing ring and bush are retained on the shaft by the bearing locknut which is locked by means of a cup-washer. The cup-washer is locked in one serration of the bearing locknut.

#### Oil seal

11. An oil seal is housed in the drive end bearing cap, this oil seal incorporates a carbon sealing ring, the face of which is maintained in contact with the steel sealing ring mounted on the armature shaft.

#### Cooling

12. The machine is cooled by blast air which enters the commutator end of the machine through the air inlet pipe. The cooling air passes over the commutator and armature and leaves the machine by one of three alternative outlets which are situated 90 degrees apart. The outlet pipe is attached to the outlet which is most convenient for the particular installation.

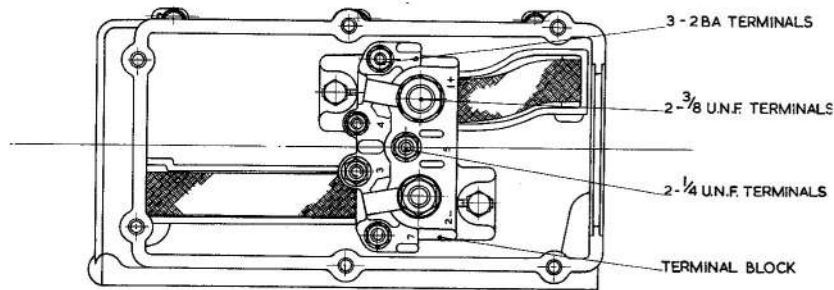

**Fig.3 View of terminal box with cover removed**

Blanking pipes remain on the two outlets not in use.

#### Terminal box

13. The connections are brought out to a moulded terminal block which is enclosed by a cast light alloy box and cover. The box is secured to the frame by six hexagon head 2 B.A. bolts.

### SERVICING

#### General

14. Ensure that all screws, bolts and electrical connections are secure and free from corrosion. Check that the armature is free to rotate before installing the generator.

#### Brushes

15. The brushes should be checked at regular intervals to ensure that they are of sufficient length and also for freedom of movement in the brush boxes. New brushes should be fitted if the rate of wear indicates that the minimum length quoted in the leading particulars may be reached before the next servicing period or examination. The brush spring pressure can be adjusted within the required limits (49½ - 55 oz.) by

depressing and rotating the adjusters in a clockwise direction to increase pressure, and in an anti-clockwise direction to decrease pressure. It is essential to ensure that the square shank of the adjuster locates in the locking recess in the brush box. Failure to ensure that the adjuster is locked will result in loss of brush spring pressure and commutator damage will result.

#### Brush bedding

16. When new brushes are fitted they should be bedded for their full thickness over at least 80 per cent of their axial width. Bedding should be carried out by running the machine as a motor with 15 volts d.c. applied to the output terminals. Connect a resistor in the field circuit to reduce the field voltage to 3-4 volts. Ensure machine is rotating in the correct direction of rotation.

#### Lubrication

17. The bearings are half filled with grease XG.271 (Ref.No. 34B/9100510) during initial assembly and will not require regreasing until bay servicing is effected. The lubricant should be evenly distributed in the bearing. The bearing cavity in the end plate is half filled with the same lubri-

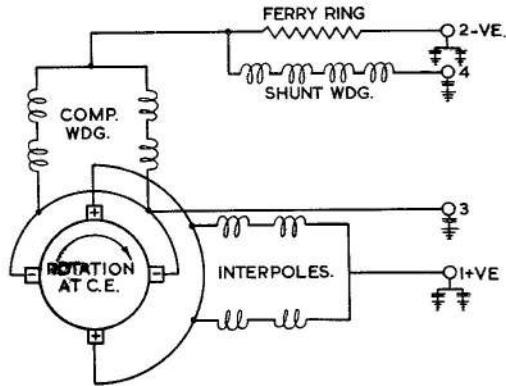

**Fig.4 Internal wiring**

cant. When assembling the machine ensure that the flange of the bearing outer race is seated squarely against the end plate otherwise premature failure of the bearing will occur. The carbon oil seal should be replaced if the drive end bearing cap is removed during servicing, this operation can be effected by pressing out the old seal and fitting a new item, the jointing faces between the seal and the bearing cap should be coated with jointing compound. The

sealing face of the carbon seal and steel sealing ring should be lightly smeared with grease XG.271 (Ref.No. 34B/9100510) prior to assembly. Care should be exercised to avoid damage to the carbon seal during assembly.

### TESTING

#### No load test

18. Mount the generator on a test bench

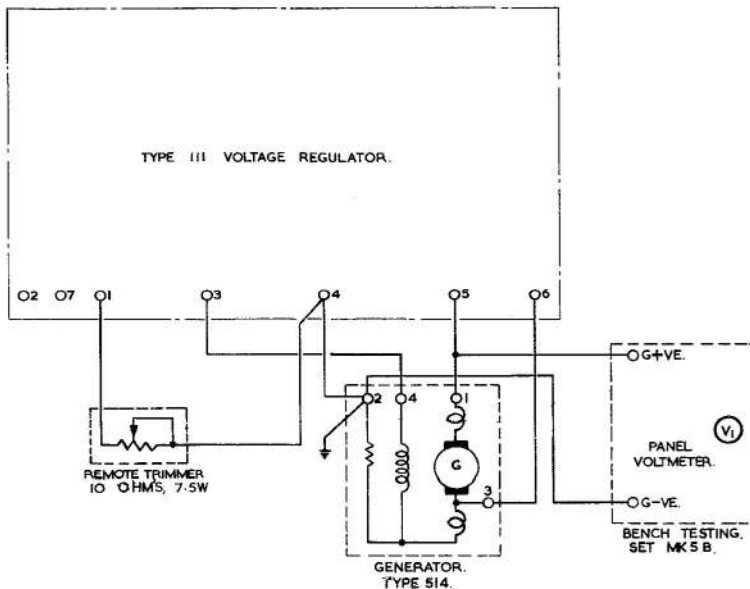

**Fig.5 Test circuit**

**RESTRICTED**

and connect as shown in fig.4 using a Type 111 regulator which has already been checked for serviceability. Run the generator in the correct direction of rotation. The generator should show no hesitation in build up to the correct voltage. The voltmeter reading should confirm the terminal markings. Should the generator fail to build up or the polarity be incorrect the poles must be remagnetised, using a 6V battery and a single pole quick break switch connected across the field windings. The positive battery lead should be connected to

terminal 4 and the negative to terminal 2. Make and break the circuit once and then run generator again to ensure the machine has been magnetised correctly.

#### **Insulation test**

19. Whilst the machine is still warm after running measure the insulation resistance between the generator terminals and the frame using a 250V insulation resistance tester. A reading of not less than 50,000 ohms should be obtained.

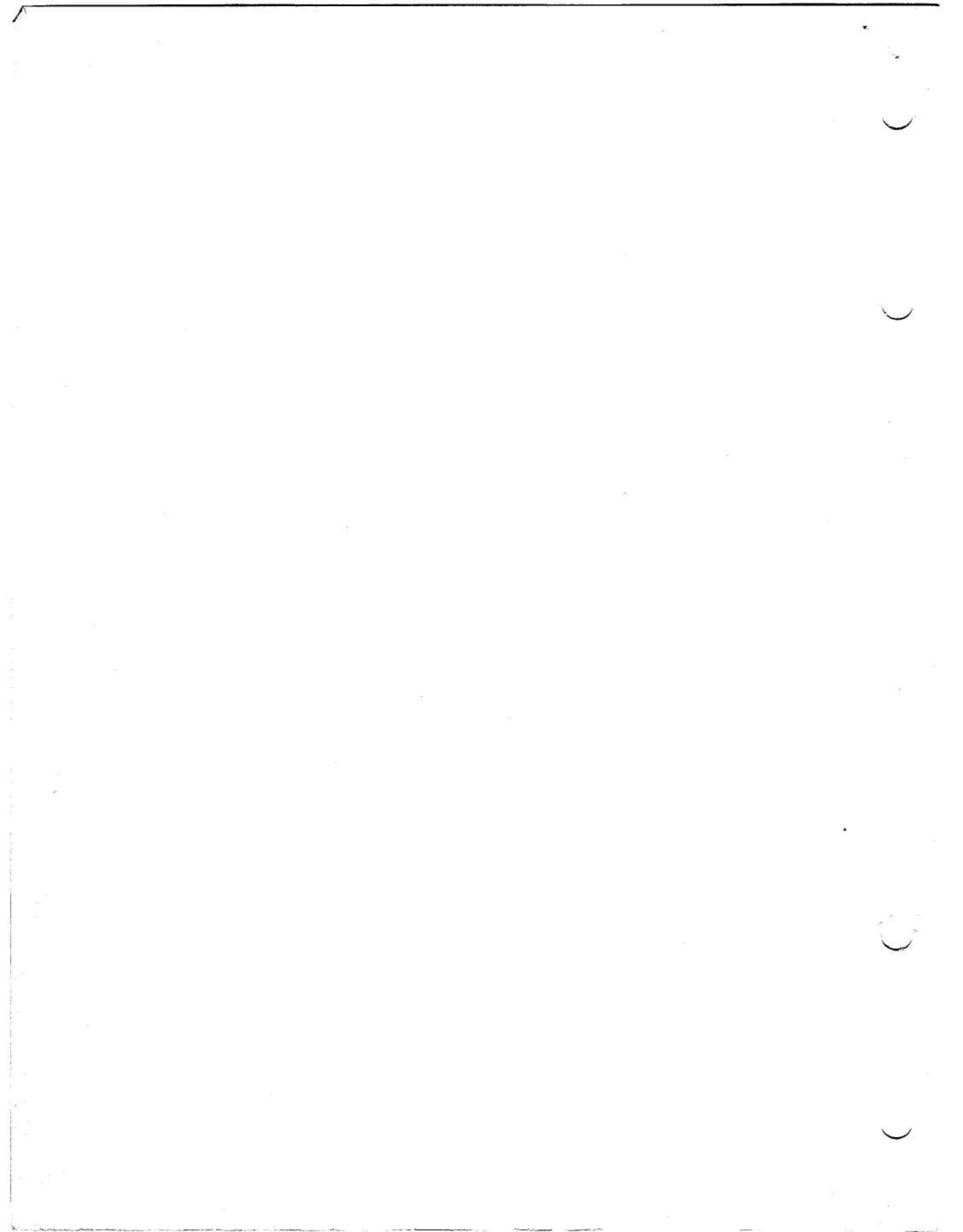

This file was downloaded  
from the RTFM Library.

Link: [www.scottbouch.com/rtfm](http://www.scottbouch.com/rtfm)

Please see site for usage terms,  
and more aircraft documents.

