

Chapter 22

GENERATOR, ROTAX, TYPE B 4101

LIST OF CONTENTS

	Para.		Para.
<i>Introduction</i>	1	<i>Electrical connections</i>	10
Description	4	Installation	11
<i>Brushes and brushgear</i>	7	Servicing	13
<i>Suppression</i>	8	<i>Lubrication</i>	17
<i>Cooling</i>	9	<i>Testing</i>	18

LIST OF ILLUSTRATIONS

	Fig.		Fig.
<i>Sectional view of B4101 generator</i>	1	<i>Installation diagram</i>	3
<i>Terminal arrangement and circuit diagram</i>	2		

LIST OF APPENDICES

		App.
<i>Standard serviceability test for generator, Rotax, Type B4101</i>	A	

LEADING PARTICULARS

Generator, Type B4101	Ref. No. 5UA/7825
<i>Output</i>	6kW, 30V d.c.
Rating—	
<i>Continuous</i>	200 amp. at 30V d.c.
<i>Overload</i>	250 amp. at 30V. d.c. for 5 minutes 300 amp. at 30V d.c. for 5 seconds
<i>Altitude</i>	16,000 ft. (max.)
<i>Speed range</i>	7,100 to 9,000 r.p.m.
<i>Rotation (viewed from drive end)</i>	Anti-clockwise
<i>Mounting</i>	Spigot (with manacle ring fixing)
<i>Brush grade</i>	EG.11 (HAM)
<i>Brush spring pressure</i>	26–32 oz.
<i>Brush length (measured on long side)—</i>	
<i>New</i>	0.937 in.
<i>Minimum permissible</i>	0.375 in.
Commutator diameter—	
<i>New</i>	2.750 in.
<i>Minimum permissible</i>	2.682 in.
<i>Maximum eccentricity of commutator</i>	0.0005 in.
<i>Maximum bar to bar variation</i>	0.0001 in.
<i>Lubricant</i>	Grease XG-271
<i>Temperature range</i>	–26 deg. C. to +55 deg. C.
Overall dimensions—	
<i>Length (including drive shaft)</i>	15.236 in.
<i>Length of spigot</i>	0.968 in.
<i>Width (including air spouts)...</i>	8.874 in.
<i>Height (including air spouts)</i>	11.350 in.
<i>Weight (estimated)</i>	38.25 lb.

RESTRICTED

Introduction

1. The B4101 generator is designed for use on the Wessex 2 aircraft and provides a d.c. power supply of 6kW at 30 volts (nominal), 200 amperes, at a speed of 7,100 to 9,000 r.p.m.
2. The machine is fully tropicalised and will operate in ambient temperatures from -26 deg. C to +55 degrees C and at altitudes up to 16,000 ft.
3. The generator operates in conjunction with Rotax voltage regulator, Type U6103, which maintains the output voltage at 28 volts $\pm \frac{1}{2}$ volt d.c., over the load and speed range of the generator.

DESCRIPTION

4. The machine is a conventional four-pole, shunt wound engine driven d.c. generator, fitted with interpoles, series connected with the armature on the negative brush side. The armature is supported on a roller bearing at the drive end, and on a ball bearing at the opposite end, as shown in the sectional view in fig. 1.
5. An oil seal is fitted at the drive end of the unit and its housing secures the roller race in position in the associated liner of the end frame.

6. An inductor coil housed in the main terminal box, which is mounted externally at the commutator end of the machine, is connected via a flexible lead through the base of the terminal box to a toroid coil secured within the commutator end frame, and the opposite end of the toroid coil connected to the field windings. These coils smooth the equalizing output signal from the generator to the associated voltage regulator.

Brushes and brushgear

7. The brushgear consists of a moulded ring incorporating the four double brush boxes, each box fitted with a carbon brush, held in position by flat coiled springs, the spring pressure being 26 to 32 oz. when the brush is in contact with the armature commutator segments. The brushgear is provided with a mounting plate for the moulded ring and spring adjusting sleeves for controlling the brush spring pressure.

Suppression

8. Radio interference is suppressed by a system of four capacitors, also housed in the main terminal box; two "through capacitors" are fitted over and in contact with the main terminal studs No. 1 and No. 2, the body of the capacitor being screwed into the counterpart of the terminal box base. The other two

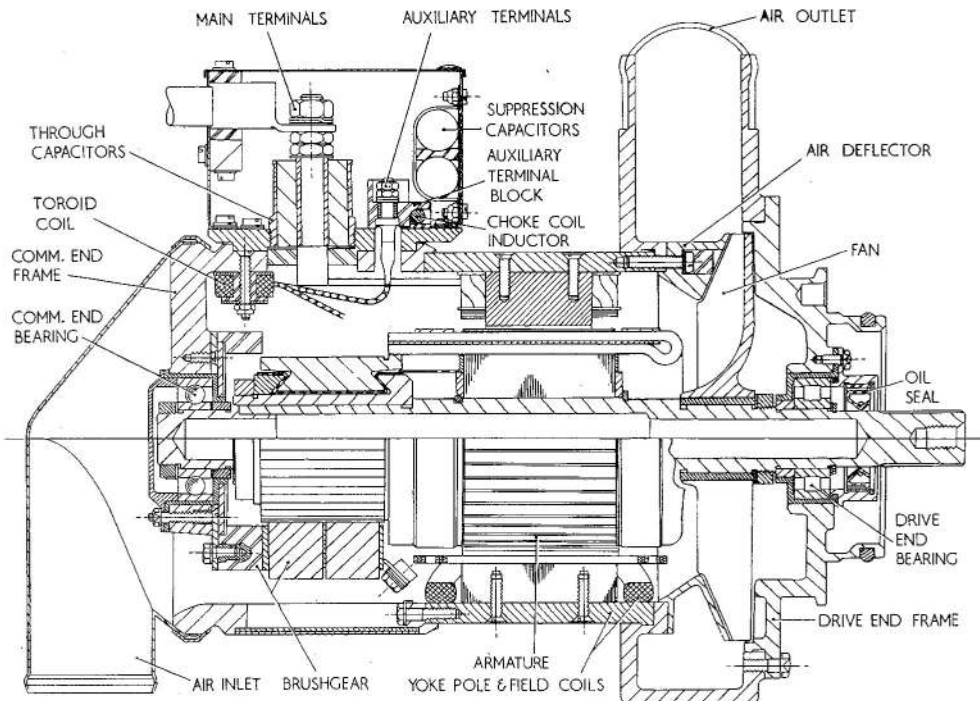

Fig. 1. Sectional view of B4101 generator

RESTRICTED

capacitors are connected to terminals No. 3 and No. 4 respectively and earthed via the main terminal box base to frame of the machine.

9. The generator is provided with an internal cooling fan fitted at the drive end of the armature shaft. An associated air deflector is fitted to the drive end housing at the air outlet end of the machine; air inlet and outlet housings are fitted externally at both ends of the unit. The estimated air flow is 120 cu. ft./min., at 7,000 r.p.m. at ground level.

Electrical connections

10. The external electrical connections are contained within the terminal box mounted on the body of the machine. Terminal studs and cable lugs are provided as follows:—

Terminals	Stud	Cable lug
(1) Armature (positive)	0.375 in. U.N.F.	Ref. No. 5X/9400103
(2) Armature (negative)		
(3) Equalizing line	10-32 U.N.F.	AMP.31889
(4) Shunt field	10-32 U.N.F.	AMP.31889

INSTALLATION

11. The unit may be mounted in any attitude using the flange of 5.700 in. diameter, with a spigot diameter of 4.124 in. designed for manacle ring fixing. The unit has a drive shaft 1.250 in. in length and 0.875 in. diameter, with 20 serrations to B.S. A19 specification (fig. 3).

12. The direction of rotation is anti-clockwise looking from the drive end. Both air spouts are 2.100 in. outside diameter with an inner taper lip diameter of 2.000 in. The air inlet spout may be secured at any suitable radial position; the air outlet is normally in the position shown in fig. 3.

SERVICING

13. The following instructions should be read in conjunction with the general chapter on the servicing of d.c. generators (to be found in A.P.4343, Vol. 1, Sect. 2, Chap. 1). The machine should be serviced as laid down in the relevant servicing schedule. For

inspecting the brushgear the following procedure should be adopted for the B4101 generator.

(1) Remove the commutator inspection cover band by unscrewing the four securing screws, and check the brush spring pressure; this should be 26 to 32 ounces when the spring radiused end is level with the top of the brush box, using tension gauge No. 1H/97.

(2) Remove the brushes from their boxes, and mark each brush to ensure correct replacement after checking the length; the minimum permissible length is 0.375 in. for each brush.

(3) If the brushes tend to bind in their boxes, wipe the box and the brush with a cloth moistened with lead-free gasoline to remove excess carbon deposit, taking care that no gasoline gets on the commutator.

14. If the brushes are worn to below the stated limits the generator must be removed from the aircraft for new brushes to be fitted

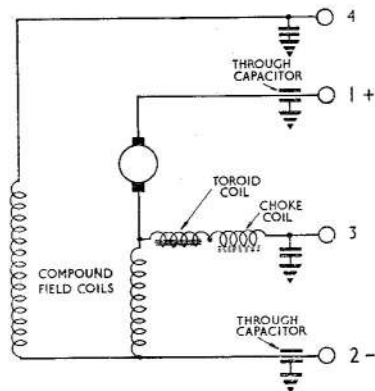
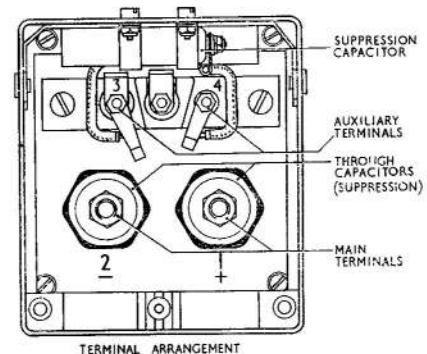

Fig. 2. Terminal arrangement and circuit diagram

RESTRICTED

and properly bedded to the commutator. care should be taken not to allow the brushes to reach the minimum limit (given in para. 16 (2)) in service. Normally there will be no need for brushes to be changed between servicing periods.

15. In the event of new brushes being fitted, the generator should be run on increasing load until the brushes are bedded in over 100 per cent of the contact area. Motoring of the generator is not advised, as it leads to brush glazing when this type of brush is fitted.

16. Ensure that all internal and external connections and lockings are secure, that no electrical tracking on mouldings is in evidence

or mouldings cracked or distorted; check the armature for signs of burning or scoring.

Lubrication

17. The bearings are pressure packed on manufacture with grease XG-271, and should not require further lubrication between major servicing periods.

Testing

18. If the serviceability of this machine is suspect, it may be tested in accordance with the test procedure laid down in Appendix A.

19. On completion of the inspection and servicing, refit the inspection cover band and lock the screws in position using new locking washers.

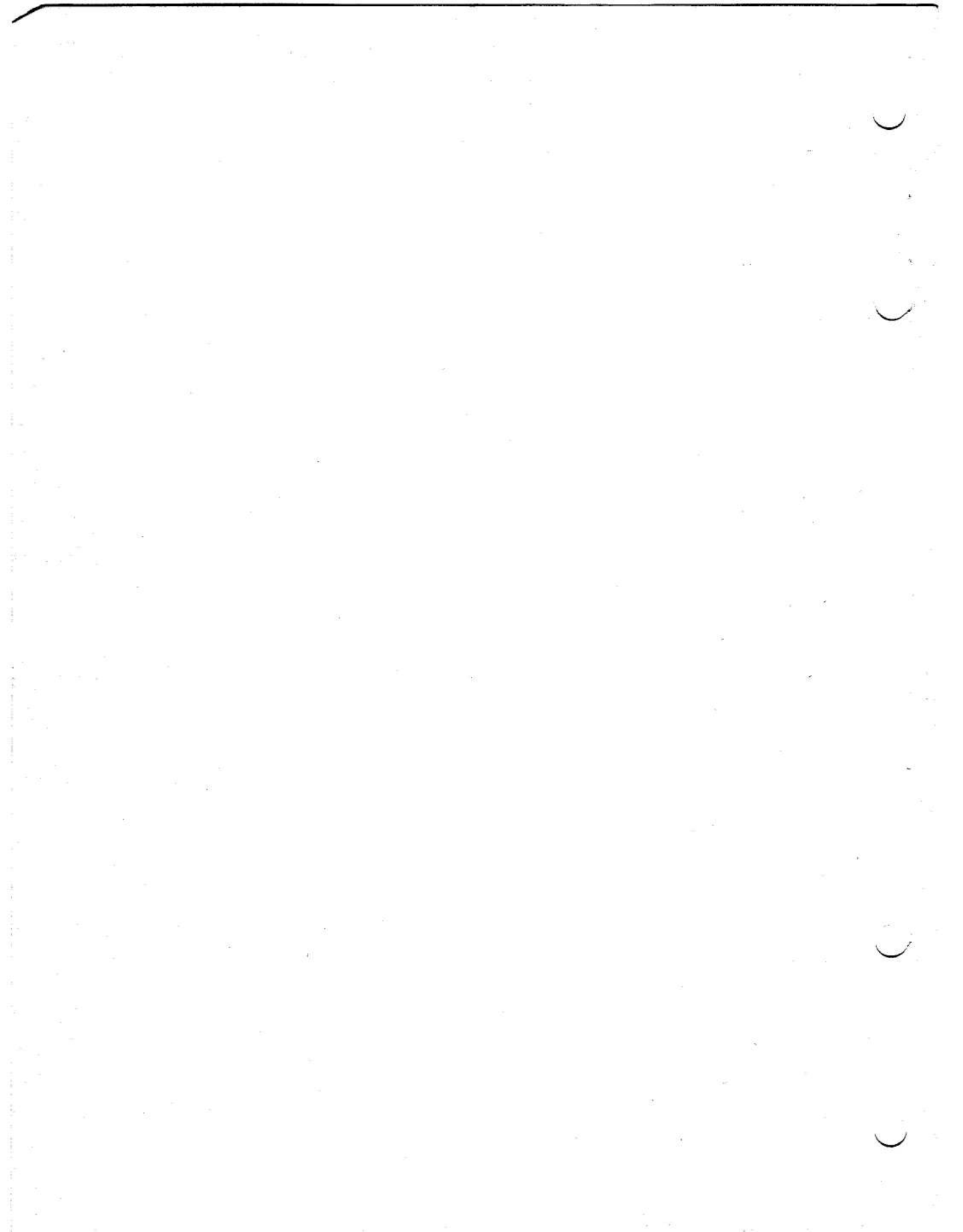

Appendix A

STANDARD SERVICEABILITY TEST FOR GENERATOR, ROTAX, TYPE B 4101

Introduction

1. The following tests may be applied to the machine before it is put into service, or at any time when its serviceability is suspect.

Test equipment

2. The following test equipment is required:—

- (1) Tester, generator—one in the Mk. 5 series.
- (2) Balance, spring, 0-4 lb. (Ref. No. 1H/97).
- (3) Insulation resistance tester, Type C (Ref. No. 5G/152).

Note . . .

If the oil seal is in position during testing, care should be taken to ensure that it is adequately lubricated with the appropriate grade of engine oil.

Testing

3. Before mounting the generator on the test set, check for freedom of rotating parts by turning the armature by hand. There should be no excessive end play in the bearings; a slight radial play which can just be felt by hand is permissible.

Brushgear

4. Check the brush length and brush spring pressure; the brush length should be not less than 0.375 in., and the spring pressure should lie between 26 and 32 oz.

Polarity

5. Run the generator in an anti-clockwise direction with a suitable voltmeter across the output terminals. The meter reading should confirm the terminal markings.

Performance

6. With the generator connected to the test set, run up on no load to approximately 7,100 r.p.m. There should be no hesitation in build-up, and the correct voltage should be attained.

7. Run at the same speed on half load (100 amp.) for 10 min. During this run, there should be no more than pin-point sparking at the brushes. At the end of the test the brushes should still slide freely in their boxes.

Insulation resistance

8. With the suppression capacitors disconnected and with the machine still warm, the insulation resistance, measured with a 250-volt insulation resistance tester between all live parts and the frame, should not be less than 0.05 megohm.

RESTRICTED

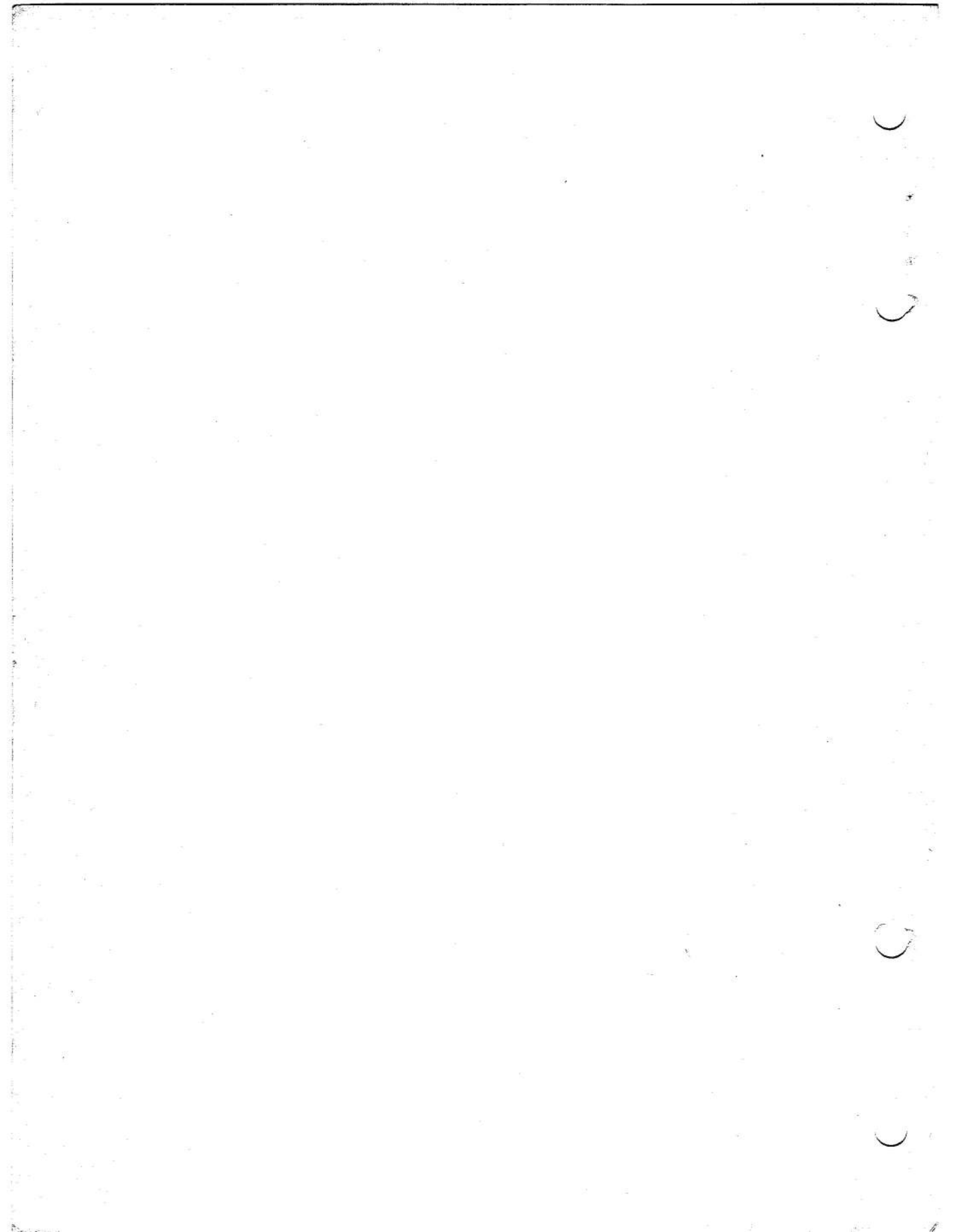

This file was downloaded
from the RTFM Library.
Link: www.scottbouch.com/rtfm

Please see site for usage terms,
and more aircraft documents.

