

Obsolete

Chapter 3

GENERATOR, TYPE KX

LIST OF CONTENTS

	Para.		Para.
Introduction	1	Brush gear	13
Description	2	Bearings and lubrication	14
Brush gear	3	Terminal box	15
Terminal box	5	Testing	16
Cooling	6	Polarity	18
Installation	8	Performance	19
Servicing	12	Insulation... ..	21

LIST OF ILLUSTRATIONS

	Fig.		Fig.
External view of generator	1	Diagram of internal connections (looking on commutator end)	4
Sectional view of generator	2	The generator dismantled	5
Terminal box	3		

LEADING PARTICULARS

Generator, Type KX

Anti-clockwise rotation	Stores Ref. 5UA/189
Clockwise rotation	Stores Ref. 5UA/190
Output	60 amp. at 28 volts
Speed range	3,300—6,000 r.p.m. (continuous operation) 7,500 r.p.m. (max. speed for five minutes)
Weight	36 lb.
Cooling	Blast cooling
Brushes	Grade EGO (H.A.M.) Stores Ref. 5UA/2384
Brush spring pressure	12—18 oz.
Lubricant	Grease XG-271 (Stores Ref. 34B/100510)
Suppressor	Type W2 (Stores Ref. 5CY/3001) or Type Y (Stores Ref. 5CY/2605)
Voltage regulator	Type F.24 (Stores Ref. 5UA/192)
Resistance of field windings	7 ohms at 20 deg. C. ± 10 per cent

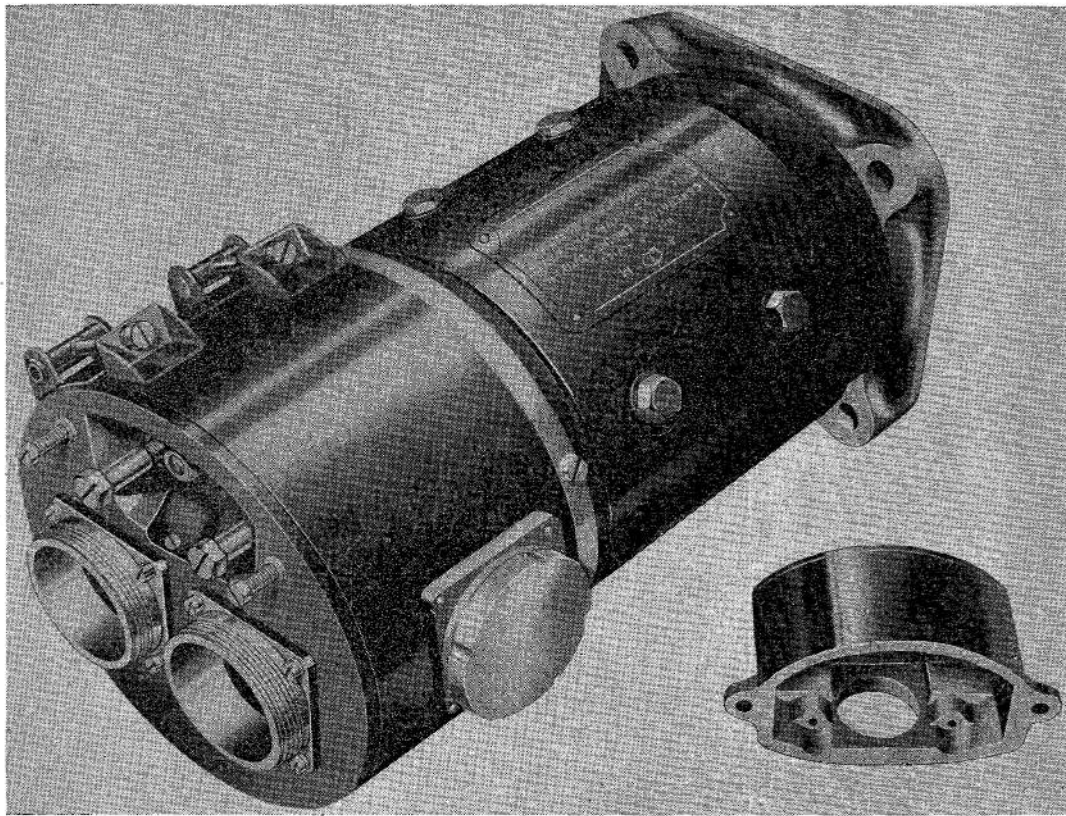

Fig. 1. External view of generator

Introduction

1. The generator, Type KX, is engine-driven and employed as a source of power for aircraft electrical installations. It has an output of 60 amp., 29 volts, which is maintained substantially constant by a voltage regulator, Type F.24.

DESCRIPTION

2. The generator (*fig. 1*), is of orthodox construction, having a four-pole shunt field system and an armature mounted in grease lubricated ball bearings, one of which is mounted in each end frame.

Brush gear

3. Four brushes are set diametrically about the commutator; connections are brought out from them to the connecting rings which are mounted on, and insulated from, the end frame, and thence to the terminals. The arrangement is illustrated in *fig. 4*.

4. To adjust the brush position, the two 6 B.A. screws and nuts which secure the brush rocker to the commutator end frame should be slackened. The nuts are accessible through the air pipe unions on the end frame. The correct position of the brush rocker is marked by corresponding white lines painted on the rocker and on the commutator end frame, or on a part rigidly attached to the end frame (usually the inner end of the field terminal).

Terminal box

5. This generator has been fitted with two types of terminal box. Earlier models were fitted with box (*Stores Ref. 5U/1171*) which is suitable for Trigenmet 2 cable only. Later models have box (*Stores Ref. 5U/373*), illustrated in *fig. 3*, and is suitable for either Trigenmet 2 or Trigenmet 3 cable. The different combinations of terminal box and cable end fittings are given in Table 1.

RESTRICTED

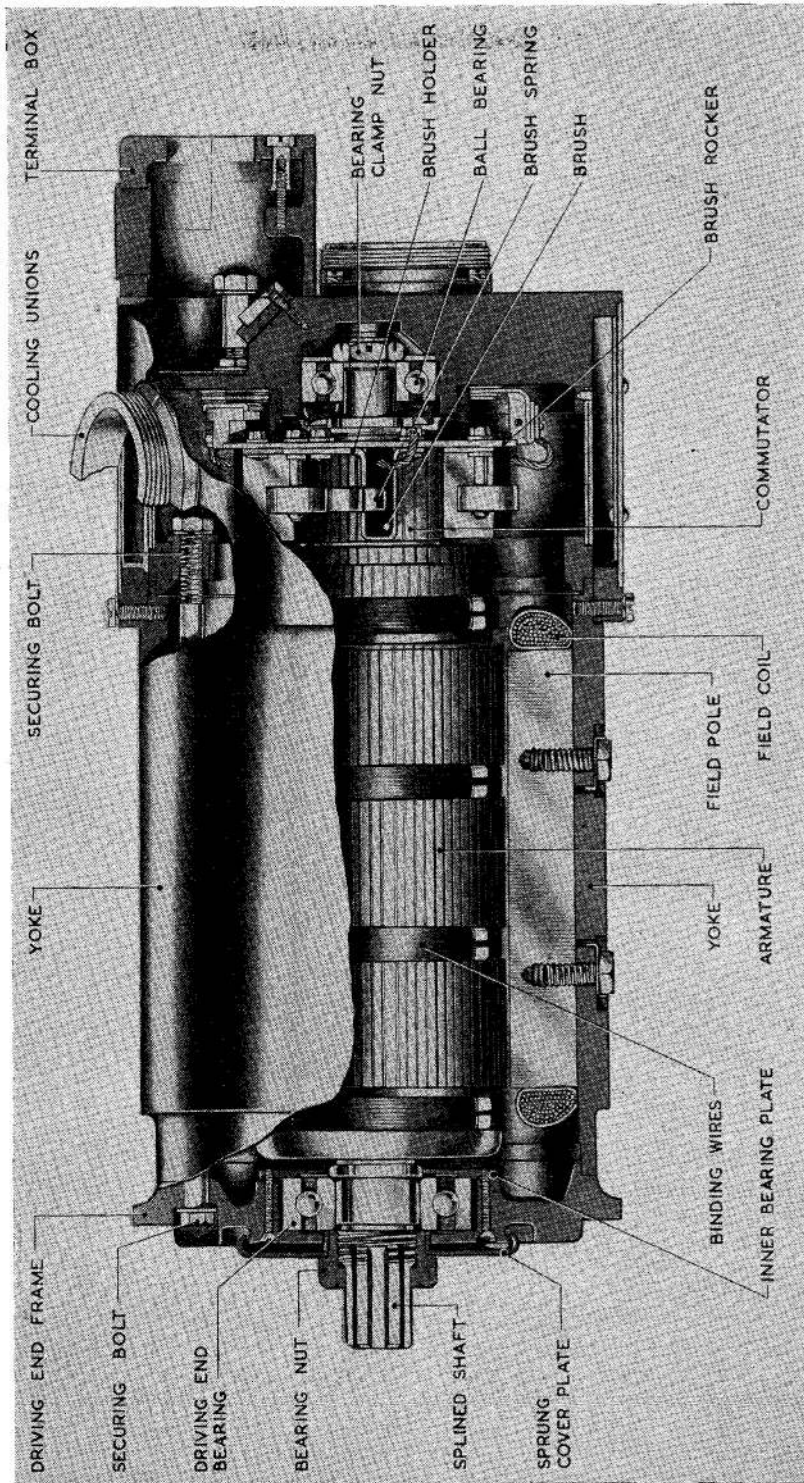

Fig. 2. Sectional view of generator

RESTRICTED

Table I
Terminal box and fittings

Cable fittings required	Box, Stores Ref. 5U/1171, with Trigenmet 2 cable	Box, Stores Ref. 5U/373, with Trigenmet 2 cable	Box, Stores Ref. 5U/373, with Trigenmet 3 cable
Positive terminal lug	A.G.S.1737—1 Stores Ref. 5C/2326	A.G.S.1737—1 Stores Ref. 5C/2326	A.G.S.1738—2 Stores Ref. 5U/2329
Negative terminal lug	A.G.S.1737—1 Stores Ref. 5C/2326	A.G.S.1737—1 Stores Ref. 5C/2326	A.G.S.1738—1 Stores Ref. 5C/2447
Field terminal lug	A.G.S.1737—2 Stores Ref. 5C/2446	A.G.S.1737—2 Stores Ref. 5C/2446	A.G.S.1737—2 Stores Ref. 5C/2446
Cable sleeve, inner	A.G.S.1660—E Stores Ref. 5K/67	A.G.S.1723 Stores Ref. 5K/192	A.G.S.1722—A Stores Ref. 5K/195
Cable sleeve, outer	A.G.S.1660—F Stores Ref. 5K/71	A.G.S.1724 Stores Ref. 5K/193	A.G.S.1722—B Stores Ref. 5K/196

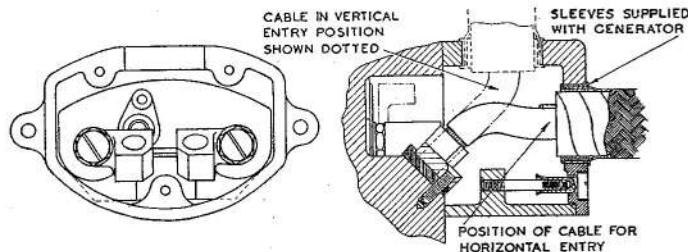

Fig. 3. Terminal box

Cooling

6. The generator is blast cooled, air from the slipstream being ducted into the machine through light alloy piping. Four unions, to which these pipes may be connected, are fitted; two are mounted on the outer face of the commutator end frame, the others being secured to the outer cover band.

7. Two cover bands are fitted to enclose the brush gear. The outer band is carried on the end frame and on a spigot support ring secured to the yoke. The inner band, which is clamped over the brush gear apertures in the end frame, has two diametrically opposed holes cut in it to allow cooling air to pass through. Both bands are located by dowel pins and it is important to check that these are in place and engaging with their corresponding slots, thus ensuring that the air pipe unions on the outer cover band are correctly placed in relation to the holes in the inner cover band.

INSTALLATION

8. As the mounting details of a generator vary with the type of engine to which it is fitted and also, on occasions, with the particular type of aircraft, the type and direction of rotation of a generator should always be checked as being appropriate to the particular installation. Details appear on the name plate attached to the yoke of the machine. Note that the direction of rotation is that in which the armature rotates when viewed from the driving end of the machine.

9. The splined end of the armature shaft should be protected by a ferrule when the generator is not in use. In some installations, a coupling member, which engages with a corresponding member on the aircraft engine, is fitted to the generator shaft. With this arrangement, the coupling member should be a close sliding fit on the shaft; it should also be secured by an axial screw which

RESTRICTED

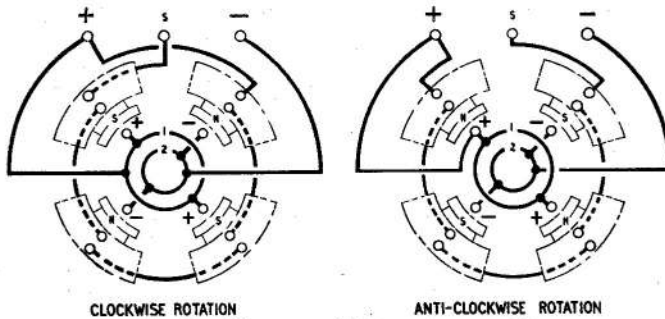

Fig. 4. Diagram of internal connections
(looking on commutator end)

must be locked after tightening. In all instances, the shaft or coupling member should be lightly coated with grease before being connected to the engine.

10. Offer up the driving end frame of the generator to the mounting face of the auxiliary gearbox on the aircraft engine. Secure the generator to the gearbox by passing bolts through the fixing holes in the driving end frame flange. Tighten the bolts evenly and firmly.

11. Connect the screened cable from the suppressor to the generator. These connections will be shown in detail in the appropriate aircraft handbook. Connect the air inlet and outlet pipes to the unions at the commutator end of the generator. After completing installation of the generator, the system should be checked for satisfactory operation.

SERVICING

12. General information relating to the care and servicing of airborne d.c. generators appears in A.P.4343, Vol. 1, Sect. 2, Chap. 1. The following instructions should be read in conjunction with that chapter.

Brush gear

13. Access to the brushes is gained by removal of the two cover bands fitted at the commutator end of the machine. The bands are described in para. 7. The brush grade is EGO (H.A.M.), Stores Ref. 5U/2384, and the brush spring pressure should lie between 12 and 18 oz.

Bearings and lubrication

14. The bearings are lubricated only when the generator is dismantled. Both are lubricated with grease XG-271 (Stores Ref. 34B/208).

Terminal box

15. The 4 B.A. screw securing the insulating plate inside the terminal box must be taken out, coated with varnish, and screwed in again whilst still wet. This precaution is necessary as cases have occurred of the screw vibrating loose and causing a short circuit.▶

Testing

16. Before installing a new or a serviced generator, the machine should be tested as laid down in the following paragraphs, using a suitable test set. If the generator fails to function correctly and the fault cannot be located and corrected, normal defect action should be taken.

17. The armature should revolve freely, without any fouling of the fixed parts or excessive end play in the bearings. A slight radial play which can just be felt by the hand is permissible.

Polarity

18. Run the generator in the correct direction of rotation, with a suitable moving coil voltmeter connected across the output terminals. The meter readings should confirm the terminal markings. It should be remembered that with a centre zero meter there is a possibility of confusion when reading the polarity.

Performance

19. With the generator connected in the appropriate test circuit, run up on no load to approximately 3,300 r.p.m. There should be no hesitation in build up, and the correct voltage should be attained.

20. Run at the same speed on half load for ten minutes. During this run, there should be no more than pin-point sparking at the brushes. At the end of the test the brushes should still slide freely in their boxes.

Insulation

21. Whilst the generator is still hot from the preceding test, the resistance of all live parts together to the frame, measured with a standard insulation resistance tester, should be not less than 0.1 megohms.

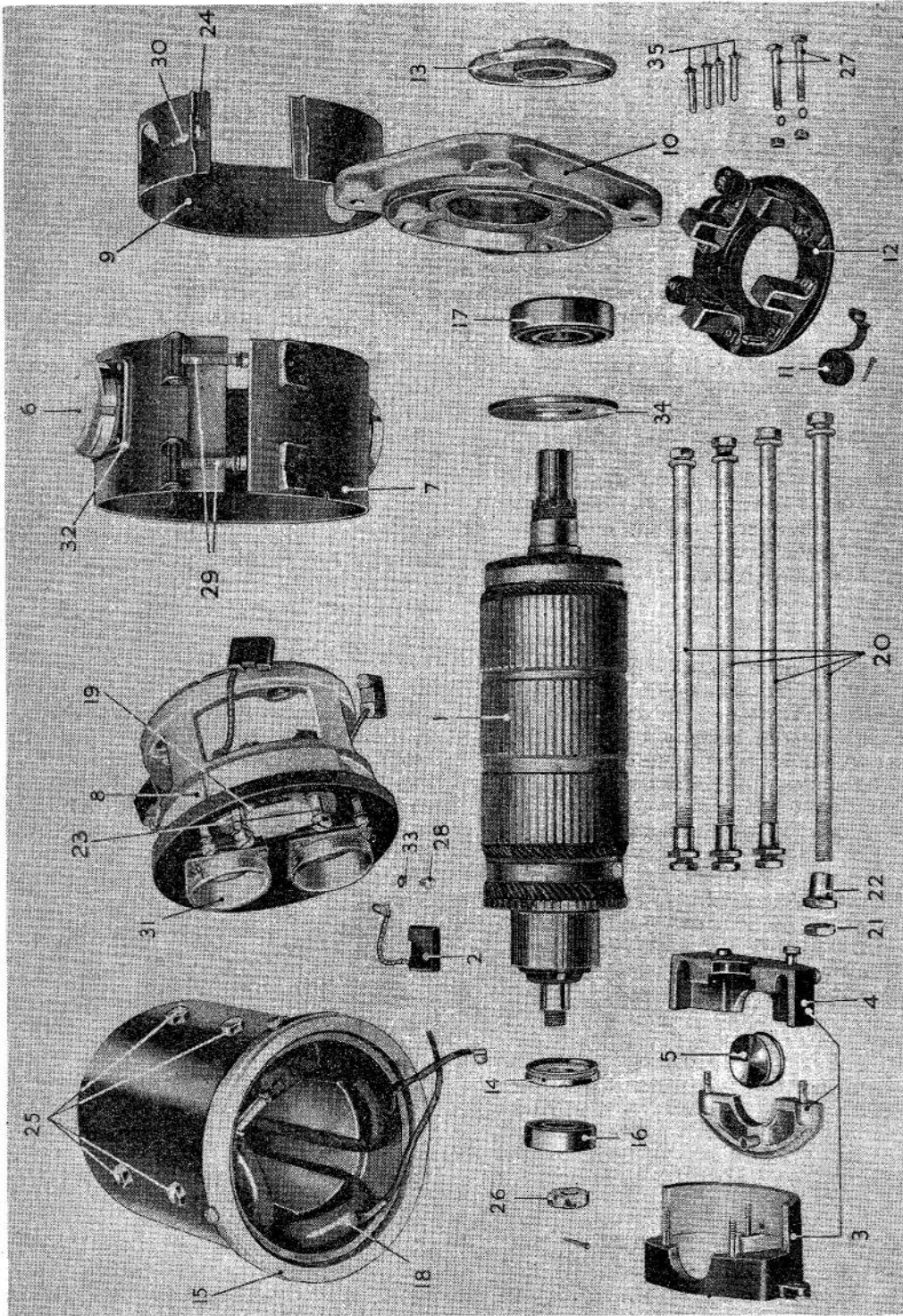
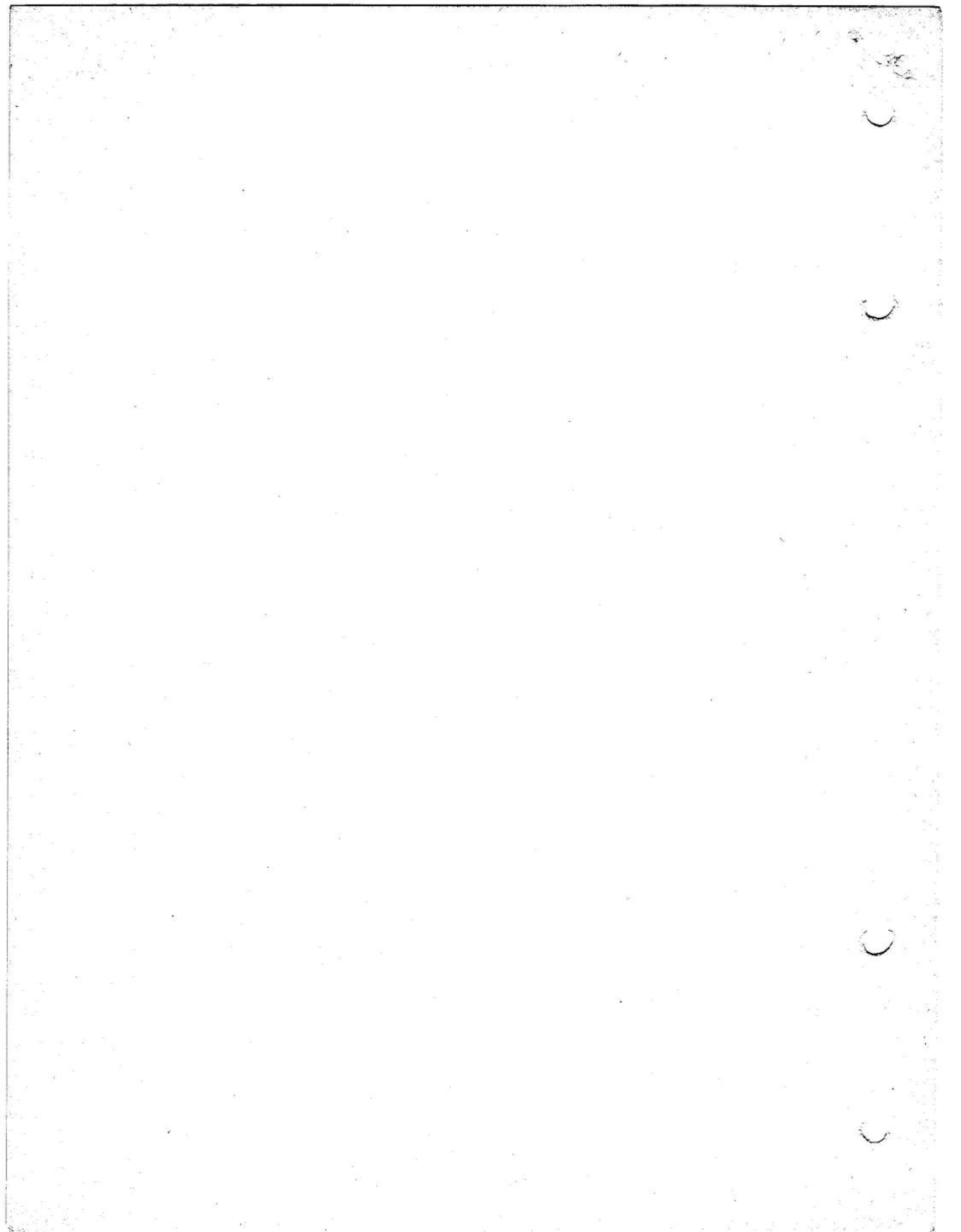

Fig. 5. The generator dismantled

KEY TO FIG. 5

- 1 ARMATURE
- 2 BRUSH
- 3 TERMINAL BOX
- 4 TERMINAL BOX LID
- 5 TERMINAL BOX PLUG
- 6 AIR PIPE UNION CAP
- 7 COMMUTATOR END COVER
- 8 COMMUTATOR END FRAME (less brush rocker assembly)
- 9 WINDOW STRAP
- 10 DRIVING END FRAME
- 11 BRUSH SPRING
- 12 BRUSH ROCKER ASSEMBLY
- 13 OIL THROWER (driving end)
- 14 OIL THROWER (commutator end)
- 15 RING SPIGOT
- 16 COMMUTATOR END BALL BEARING
- 17 DRIVING END BALL BEARING
- 18 FIELD COILS
- 19 INSULATING PLATE
- 20 END FRAME FIXING BOLTS
- 21 FIXING BOLT LOCK-NUT
- 22 NUT FOR FIXING BOLT
- 23 TERMINAL FIXING NUT
- 24 WINDOW STRAP NUT
- 25 POLE PIECE FIXING BOLT
- 26 ARMATURE SHAFT NUT
- 27 BRUSH ROCKER FIXING SCREWS
- 28 BRUSH GEAR CONNECTION SCREWS
- 29 COMMUTATOR END COVER SCREWS
- 30 WINDOW STRAP SCREWS
- 31 AIR PIPE UNION FOR COMMUTATOR END FRAME
- 32 AIR PIPE UNION FOR COMMUTATOR END COVER
- 33 BRUSH CONNECTION LOCK-WASHERS
- 34 INNER BEARING PLATE
- 35 INNER BEARING PLATE SCREWS

RESTRICTED



This file was downloaded
from the RTFM Library.

Link: www.scottbouch.com/rtfm

Please see site for usage terms,
and more aircraft documents.

