

Chapter 30

GENERATOR, E.E., TYPE AE2512

LIST OF CONTENTS

	Para.		Para.
<i>Introduction</i>	1	<i>Cleaning</i>	11
Description		<i>Brushgear</i>	13
<i>General</i>	2	<i>Brush bedding</i>	17
<i>Frame</i>	3	<i>Oil seal</i>	19
<i>Armature</i>	4	<i>Bearings and bearing lubrication</i>	22
<i>Endplates and bearings</i>	5	<i>Commutator</i>	27
<i>Brushgear</i>	6	<i>Terminals and terminal box</i>	30
<i>Terminal box</i>	7	Testing	
<i>Cooling</i>	8	<i>General</i>	32
Servicing		<i>Re-magnetizing</i>	37
<i>General</i>	9	<i>Insulation resistance test</i>	38

LIST OF ILLUSTRATIONS

	Fig.
<i>Generator Type AE2512</i>	1
<i>Sectioned view</i>	2
<i>Circuit diagram</i>	3
<i>Test circuit diagram</i>	4

LEADING PARTICULARS

Generator, Type AE2512	5UA/
<i>Rated output</i>	4kW
<i>Rated voltage</i>	30V d.c.
<i>Current</i>	133A
<i>Rotation (looking on drive end)</i>	Clockwise
<i>Speed range</i>	5710-9500 rev/min
<i>Rating</i>	Continuous
<i>Voltage regulator, Type 94</i>	Ref. No. 5UC/5937
<i>Regulated voltage</i>	28V (± 2.5 per cent)
<i>Brush grade</i>	EG 12
<i>Brush spring pressure</i>	17½-22½ oz.
<i>New brush length</i> } <i>Measured on</i>	5/8 in.
<i>Minimum permissible</i> } <i>shortest side</i>	
<i>brush length</i>	5/16 in.
<i>New commutator diameter</i>	3 in.
<i>Minimum permissible commutator diameter</i>	2.950 in.
<i>Commutator undercut</i>	1/32 in.
Dimensions—	
<i>Overall length</i>	10.75 in.
<i>Overall width (of flange)</i>	7.85 in.
<i>Overall height</i>	9.75 in.
<i>Weight</i>	27 lb.

RESTRICTED

Introduction

1. The Type AE2512 d.c. generator is a wide speed range, air blast cooled, flange mounted machine designed to operate with a Type 94 voltage regulator at altitudes between sea level and 10000 ft.

DESCRIPTION

General

2. The generator is a 6 pole-shunt wound machine fitted with interpoles and compensating windings. It has a retrogressive wave wound armature whose shaft is supported at the drive end and commutator end in ball and roller bearings respectively. The mounting flange is of standard design with sixteen equally spaced fixing holes.

Frame

3. The frame is rolled and welded from high permeability steel plate. It houses the six main poles and auxiliary poles, and the compensating windings.

Armature

4. The armature has a hollow, high tensile steel shaft which supports the core and commutator. The core is laminated and carries the armature coils in 43 slots. The

shaft is splined at the drive end for connecting to a prime mover.

Endplates and bearings

5. The two endplates are of cast magnesium alloy and are spigot located to the frame. The drive-end endplate, which incorporates the mounting flange, houses a ball bearing and an oil seal. The commutator-end endplate houses a roller bearing, and also supports the brushgear. Fitted to the outer face of the commutator-end endplate is a combined cover and air inlet pipe which is fixed to the endplate by five clamps. These clamps, if slackened, allow the inlet pipe to be moved radially on the endplate to any desired position.

Brushgear

6. The brushgear consists of a moulded rocker ring secured to which are six brush boxes. Each brush box has a single carbon brush retained by a coil spring, and an adjusting mechanism is fitted to maintain the spring pressure on the brush. Two equalising rings fit round the rocker.

Terminal box

7. The terminal box is secured to the frame. It contains a moulded terminal block

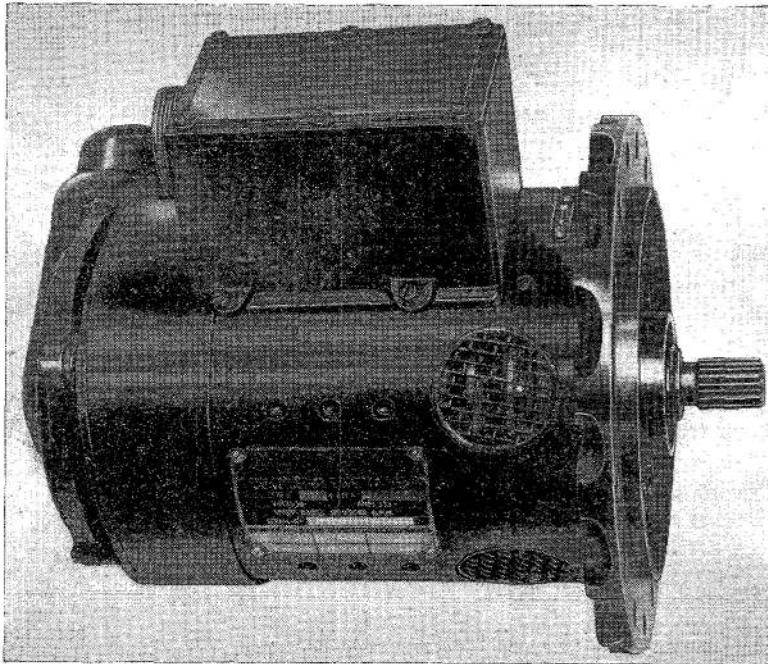

Fig. 1. Generator, Type AE2512

RESTRICTED

for the internal and external connections, and a bank of six suppression capacitors. A flanged connector is fitted to the box for external cabling, and a cover is fitted which completely encloses the terminals.

Cooling

8. Blast cooling air is fed into the generator at the commutator end through the inlet pipe. This cool air passes through holes in the commutator-end endplate and over the brushgear to the commutator and field coils. Cool air also passes through the hollow armature shaft. Warm air collecting at the drive end of the generator is expelled through five meshed vent holes in the frame.

SERVICING

General

9. Information on servicing common to all d.c. generators will be found in A.P.4343, Vol. 1, Sect. 2, Chap. 1. The following paragraphs should be read in conjunction with that Chapter and the relevant Servicing Schedule.

10. To examine the machine disconnect the air pipe and remove the band cover at the commutator end of the frame. Remove also the terminal box cover.

Cleaning

11. Thoroughly clean the exterior of the machine giving particular attention to the drive-end endplate and the frame vent covers.

12. Clean also the band cover and the inside of the cover and air pipe, remove if necessary. Clean the inside of the frame at the commutator end and ensure that all traces of carbon dust are removed.

Brushgear

13. Thoroughly clean the brushgear and ensure that all traces of carbon dust are removed. Check the security of all components and of the electrical connections. Examine for damage to the rocker ring, brush boxes, brush springs.

14. Take out the brushes and examine them. Ensure that they are not broken, chipped or cracked and that they have not worn near to or beyond the recommended

minimum length—see Leading Particulars. Brushes damaged in any way should be renewed, and so also should those whose length indicates that before the next scheduled inspection they will wear beyond the minimum recommended.

15. Brushes should be replaced in the same holders exactly as before removal. New brushes should be tried in the holders to ensure freedom of movement.

16. Check the brush spring pressure and adjust as necessary to give pressure quoted in Leading Particulars. Use a spring balance and take readings when brush spring is raised $\frac{1}{16}$ in. above top of brush box.

Brush bedding

17. New brushes should be bedded over their full width and radial thickness. Brush bedding should be performed by running the machine as a motor as follows:—Connect a 10V d.c. supply to terminals 1 and 2 and connect a 2 ohm resistor to terminals 1 and 4. The machine will take about 10A under these conditions and no cooling will be required; ensure that the correct direction of rotation is obtained.

Note . . .

This machine must not be run on a bench or test rig without first removing the oil seal at the drive end. Failure to do this will cause irreparable damage to the seal and possibly to the shaft. The seal should be removed as described in para. 19.

Oil seal

18. This should be examined periodically and if found to be even slightly worn or damaged must be renewed.

19. To remove the oil seal, take out the internal circlip, remove the spring ring from the seal and withdraw the seal. To facilitate replacement lightly smear the seal with XG-271 grease, and refit the spring ring and circlip.

Bearings and bearing lubrication

20. The bearings are high speed, three circle fit, ball and roller types. They are correctly lubricated during manufacture and require no further attention until the generator is scheduled for bay servicing.

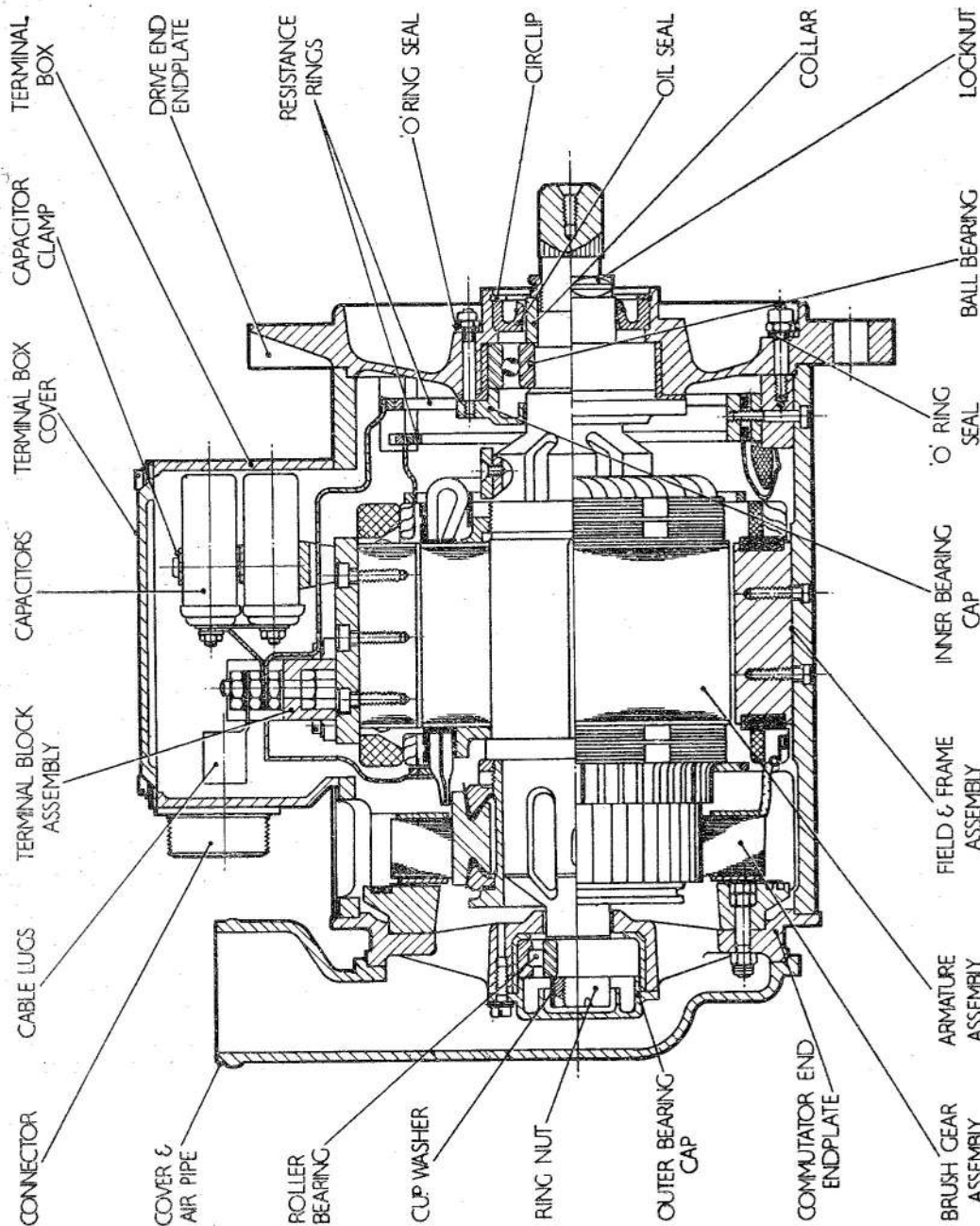

Fig. 2. Sectioned view

21. During bay servicing the bearings should be thoroughly cleaned, examined and relubricated. To do this it is necessary to remove the two endplates. First lift the brushes clear of the commutator surface, then, to examine the drive end bearing remove the six 2BA locknuts and seals securing endplate to frame and the four 4BA lock-

nuts and seals securing inner bearing cap to endplate. To withdraw the endplate it may be necessary to give one or two sharp taps on the flange to break the sealed joints. To examine the tail end bearing remove the five screws and clamps and take off the cover and air pipe. Remove the four screws and take off the outer bearing cap. Discon-

RESTRICTED

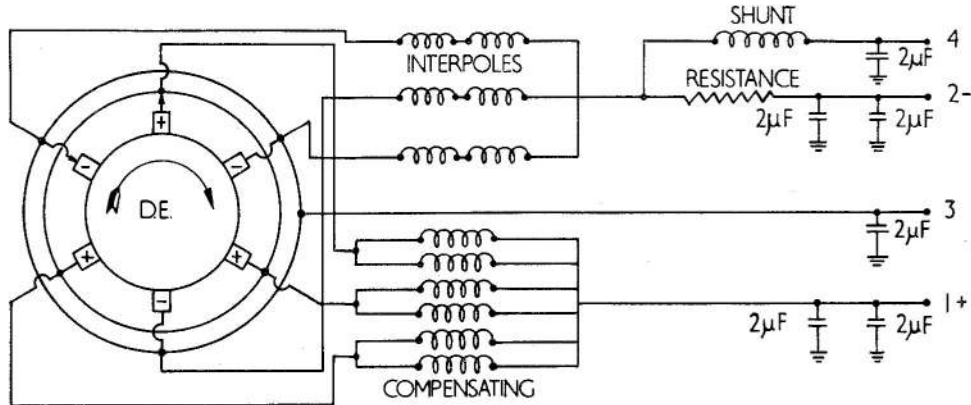

Fig. 3. Circuit diagram

nect the leads from the brush boxes, remove the six fixing screws and withdraw the end-plate complete with brushgear. Note that the inner race of the roller bearing will remain on the armature shaft.

22. Thoroughly clean both bearings. Do not remove the drive end bearing or tail end inner race from shaft unless either bearing is unserviceable.

23. The bearings fitted to earlier models of this generator are lubricated by oil soaked felt pads housed in the bearing caps. These pads should be removed and discarded. On assembly soak the new pads thoroughly in oil OM-270 before placing them in the bearing caps.

24. Bearings fitted to later models are grease lubricated. After dismantling, the old grease should be cleaned from the bearing caps, housings, and on assembly grease XG-271 should be applied by one third filling each bearing and two thirds filling each bearing cap.

Commutator

25. The commutator should have a smooth polished surface with a uniform, low resistance, oxide film. If necessary the surface may be cleaned with a piece of lint free rag dipped in unleaded gasoline.

26. If the surface is badly worn, grooved or pitted, it should be skimmed between lathe centres. When doing so, check that the bearing diameters are concentric to

within 0.0005 in. T.I.R. and the peripheral speed of the commutator is not less than 500 rev/min. A diamond tipped tool should be used and the surface finish should not exceed 8 micro-inches. Commutator diameter to be concentric with bearing diameter to within 0.0005 in. Mica separators should be undercut $\frac{1}{32}$ in. deep. Check that finished diameter is not less than that given in Leading Particulars.

27. Check that the terminals, terminal block and capacitors are clean and that all connections are electrically sound and firmly secured. Check for cracks in the terminal block.

28. Check the security of the terminal box and flanged connector, and see that the threads of the terminal box cover fixing screw holes are not stripped.

TESTING

General

29. Before running the machine ensure that the oil seal has been removed. Turn the armature by hand to check for smooth rotation and to ensure that it does not foul any leads or other fixed parts of the machine. There should be no excess end-float, although slight radial play which can just be felt by hand is permissible.

30. A Type 94 voltage regulator previously tested for correct operation should be used and the generator should, if possible, be driven by a MK 5D generator test bench

RESTRICTED

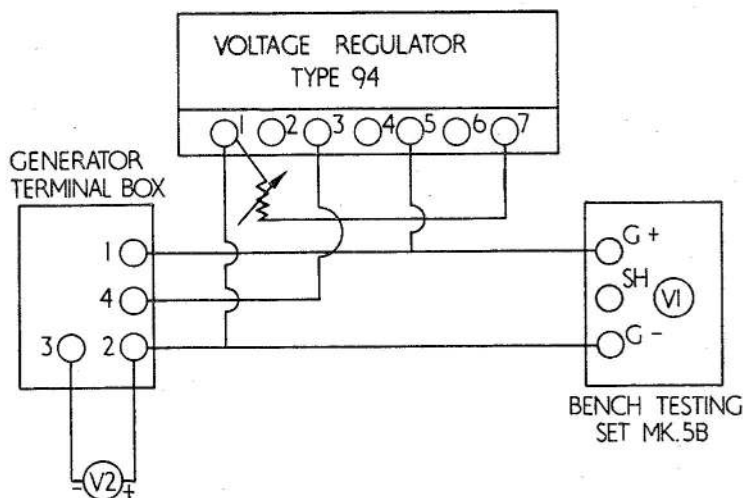

Fig. 4. Test circuit diagram

(Ref. No. 5G/2924). This test bench is described in A.P.4343S, Vol. 1, Book 1, Sect. 13, Chap. 1.

31. The generator should be connected up as shown in the test circuit diagram, fig. 4. Note the external trimmer resistor connected between terminals 1 and 7 on the voltage regulator, and millivoltmeter V2 connected to terminals 2 and 3 on the generator with polarity as shown. Voltmeter V1 should be on the 0-40V range. The fixed load resistor on the test set should be switched out and the variable load rheostat adjusted to the minimum load position.

32. Run the generator in the correct direction of rotation (i.e. clockwise looking on drive end) at a speed of 5710 rev/min and observe readings on V1 and V2. If positive readings are indicated as the voltage builds up the polarity of the generator is correct. The terminal voltage of the generator, indicated by V1, should build up without hesitation to between 27.5 and 28.5V.

33. If positive voltmeter readings are not indicated check all connections and ensure the direction of rotation is correct. If the polarity should still be incorrect or should the terminal voltage fail to build up, the

generator must be disconnected from the test circuit for re-magnetization of the field poles.

Re-magnetizing

34. To re-magnetize the field poles connect a 6 volt battery in series with a single-pole, quick-break switch. Connect the positive battery lead to terminal 4 and the negative lead to terminal 2. Using the switch, make and break the circuit once only. Disconnect battery and switch and carry out tests described in para. 32-35.

Insulation resistance test

35. Whilst the generator is still hot after testing, measure the insulation resistance, using a 250V d.c. tester, between generator terminals and frame. The value obtained should not be less than 50000 ohms.

36. Readings below this value may indicate heavy deposits of carbon dust or other conductive material on the terminal block, brushgear, windings, frame etc. In which case the generator must be dismantled and thoroughly cleaned. If the machine has already been cleaned and a low reading of insulation resistance is obtained, disconnect the interference suppression capacitor and check them for breakdown.

RESTRICTED

This file was downloaded
from the RTFM Library.

Link: www.scottbouch.com/rtfm

Please see site for usage terms,
and more aircraft documents.



LIGHTNING MK. 1
COVER PITOT HEAD
EB2-88-511