

Obsolete

### Chapter 7

## GENERATOR, TYPE P2

### LIST OF CONTENTS

	Para.		Para.
Introduction ... ..	1	Operation ... ..	15
Description ... ..	2	59 Servicing ... ..	16
Brush gear ... ..	3	Bearings ... ..	18
Connections ... ..	6	Adapter ... ..	24
Cooling ... ..	7	Lubrication ... ..	25
Armature and commutator... ..	8	Brushes and brush gear ... ..	26
Bearings and lubrication ... ..	9	Testing ... ..	27
Yoke ... ..	11	Polarity ... ..	29
Driving end frame ... ..	12	Performance ... ..	30
Installation ... ..	13	Insulation ... ..	32

### LIST OF ILLUSTRATIONS

	Fig.		Fig.
Generator, Type P2 ... ..	1	Driving and commutator end frames ... ..	4
Internal connections ... ..	2	Armature with bearings ... ..	5
Terminal arrangement ... ..	3	Adapter ... ..	6

### LEADING PARTICULARS

#### Generator, Type P2

Clockwise rotation ... ..	Stores Ref. 5UA/4531
Anti-clockwise rotation ... ..	Stores Ref. 5UA/4530
Output ... ..	200 amp. at 30 volts
Speed range ... ..	3,250 r.p.m. to 4,800 r.p.m. cont. 6,000 r.p.m. (max.) for 5 min.
Brushes—	
Grade ... ..	Type EG12/2, H.A.M. (Stores Ref. 5UA/4196)
Minimum length ... ..	0.42 in.
Brush spring pressure ... ..	17 to 19 oz.
Lubricant ... ..	Oil OM-170 (Stores Ref. 34B/100553)
Weight ... ..	57 lb.
Voltage regulators—	
Type 23 (generator) ... ..	Stores Ref. 5UC/2844
Type 32 (master) ... ..	Stores Ref. 5UC/2899
Resistance at 20 deg. C—	
Field windings ... ..	1.5 ohms ± 10 per cent

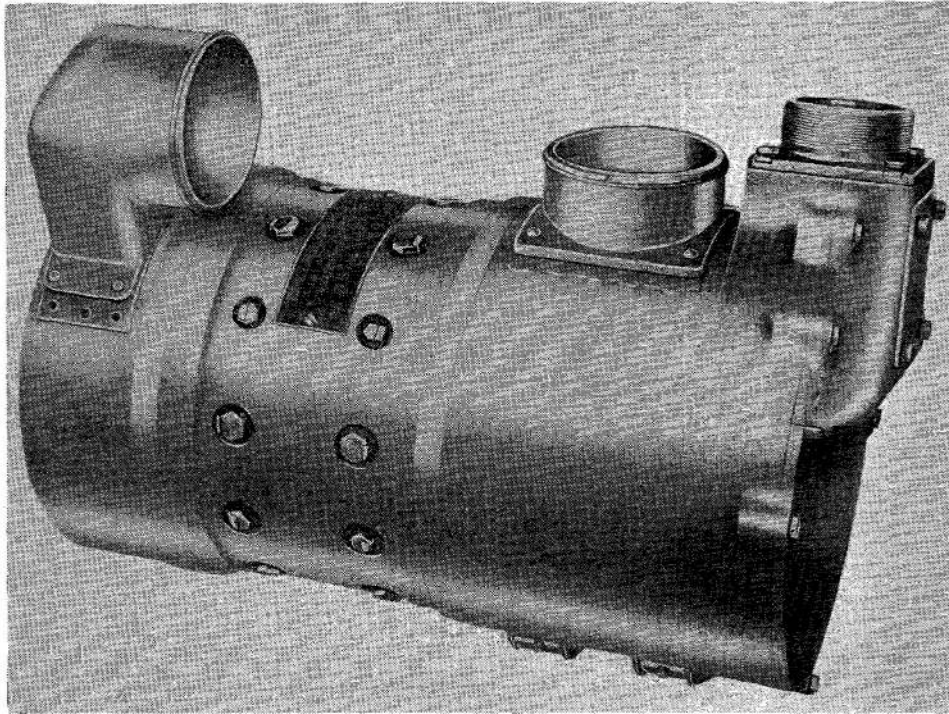

**Fig. 1. Generator, Type P2**

#### **Introduction**

1. The engine driven generator, Type P2 (*fig. 1*) is designed to give an output of 200 amp., 30 volts d.c. With the original, but now obsolete, generator, Type P, it was possible to change the direction of rotation by altering the field link, but with the P2 different machines are used for clockwise and for anti-clockwise rotation.

#### **DESCRIPTION**

2. The machine is 6-pole, self-excited, shunt-wound and is fitted with six interpoles. The interpole windings are connected in series with, and between the negative brushes and the negative main output terminal (*fig. 2*). A shunt is connected across the interpole windings.

#### **Brush gear**

3. There are six brush-holders, each accommodating two brushes mounted end to end. Two fixing studs passing through insulating bushes in the end frame secure each box, the boxes thus being attached to, but insulated from the frame.

4. The positive and negative brush inter-connecting strips are fitted on the studs, and each assembly is secured by a double locking plate and two nuts. The bolts holding the end frame to the yoke pass through slotted holes which allow a circumferential movement of the brush gear assembly.

5. Access to the brush gear connections is obtained by removing the commutator end frame cover plates. These are in two sections and are secured by screws and locking washers, the main output terminals being accessible through the top portion.

#### **Connections**

6. The supply leads from the generator should be connected to the two main output terminals and to one of the field terminals, the field terminal used depending on the direction of the rotation of the machine (*fig. 2 and 3*). Another terminal is connected to the negative brush connecting strip and to one end of the interpole winding. The other end of the interpole winding is taken to the negative main output terminal.

**RESTRICTED**

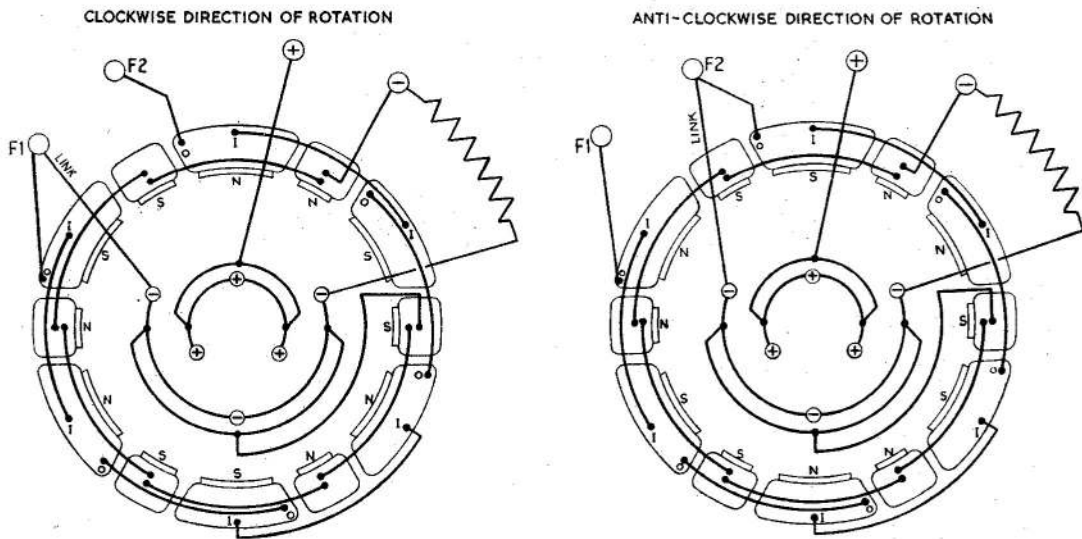

VIEW ON COMMUTATOR END

Fig. 2. Internal connections

The shunt, or interpole diverter is connected to the negative brush inter-connecting strip and to the negative main output terminal, whilst the ends of the field winding are brought out to the field terminals.

**Cooling**

7. Air from the slipstream is used for cooling the generator. The inlet and outlet pipes are fixed to unions mounted on the commutator and driving end cover bands. The bands are slotted, the slots locating with a spigot on the end frames, thus permitting the unions to be fitted in any of the four positions to suit different installations.

**Armature and commutator**

8. The part of the armature shaft carrying the armature laminations is hollow and of large dimensions. Six holes drilled in each end of the hollow centre section allow cooling air to flow inside the armature and commutator. Three sets of binding wires are used to secure the armature conductors in position.

**Bearings and lubrication**

9. The armature (*fig. 5*) rotates in two ball bearings, that at the commutator end being a push fit in its housing, thus allowing for limited lateral movement. This relieves axial load due to differential expansion

caused by heating which occurs when the generator is run on full load.

10. The lubricant is retained in felt reservoirs in the outer bearing caps, and a felt wiper washer is located both sides of the two bearings.

**Yoke**

11. Twelve pole pieces are bolted in the bore of the yoke, six for the main field, and six for the interpole windings. The ends of the windings are brought out and connected to the brush gear and terminals (*para. 6*).

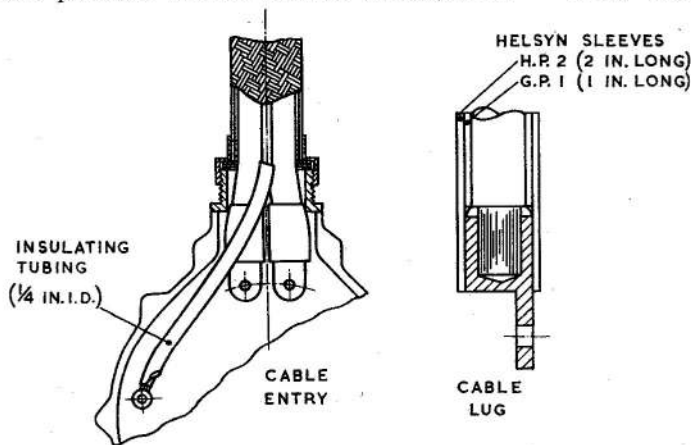
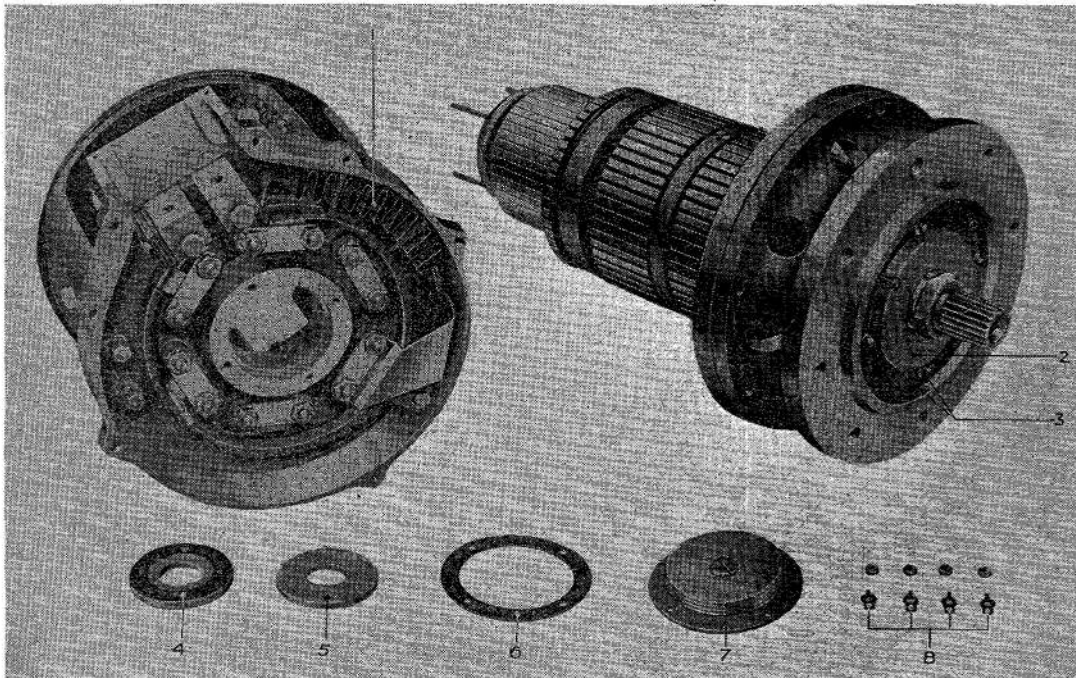

Fig. 3. Terminal arrangement

**RESTRICTED**



- |  |  |
|--|--|
| 1 SHUNT                                    | 5 COMMUTATOR END PLAIN FELT WASHER           |
| 2 DRIVING END OUTER BEARING CAP            | 6 CORK GASKET                                |
| 3 DRIVING END OUTER BEARING CAP NUTS       | 7 COMMUTATOR END OUTER BEARING CAP AND FELTS |
| 4 COMMUTATOR END OUTER FELT DISC AND WIPER | 8 COMMUTATOR END NUTS AND LOCKING TABS       |

Fig. 4. Driving and commutator end frames

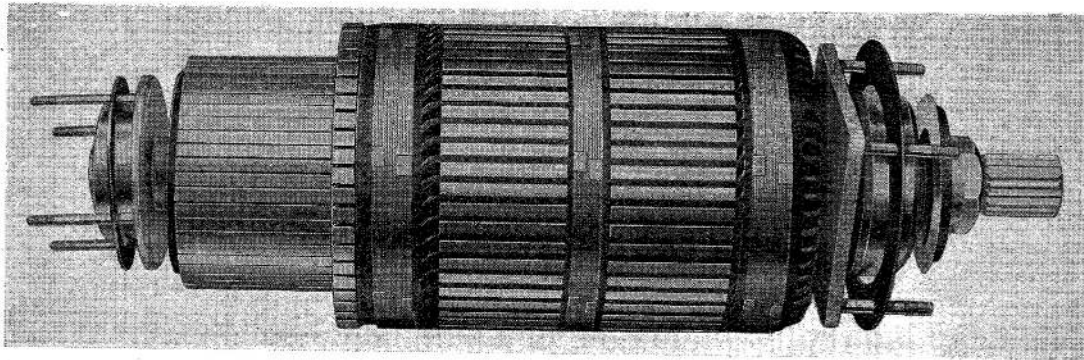

Fig. 5. Armature with bearings

RESTRICTED

**Driving end frame**

12. Two flanges, integral with the driving end frame, are located one at the outer end and one at the yoke end (*fig. 4*). That at the outer end is drilled to accept bolts for fixing the generator to the engine gearbox. Holes are drilled between the two flanges to provide outlet for the cooling air passing through the yoke, the space between the flanges being closed by a cover band that carries the outlet air pipe union.

**INSTALLATION**

13. Before installation always ensure that the direction of rotation of the generator is suited to the engine to which it is being fitted. Remove the protecting ferrule and inspect the drive coupling for any signs of damage. Always fit a ferrule after a generator has been removed from an engine.

14. Information on the care of, and anti-corrosive treatment for air pipes will be found in A.P.4343, Vol. 1, Sect. 2, Chap. 1.

**OPERATION**

15. The machine is driven through gearing by the aircraft engine, its output being controlled by a voltage regulator, Type 23. When generators are connected in parallel their combined outputs are governed additionally by a regulator, Type 32. A full description of such a system is given in A.P.4343B, Vol. 1, Sect. 1, Chap. 3.

**SERVICING**

16. Information on servicing common to all d.c. generators will be found in A.P.4343, Vol. 1, Sect. 2, Chap. 1, and the following instructions should be read in conjunction with that chapter.

17. Inspection should be made as laid down in the relevant Servicing Schedule. The generator should not be removed from the engine unless detailed examination or lubrication is necessary. The commutator covers should be removed and the internal wires examined for security and serviceability. All nuts, unions, fixing screws, and locking devices should be checked and tightened if and where necessary. The terminal connections should be made as shown in *fig. 3*.

**Bearings**

18. Dismantling should normally be done at a Maintenance Unit, but when lubricating and inspecting the bearings the following procedure may be adopted:—

- (1) Remove the generator from the aircraft.
- (2) Unlock and remove the screw securing the driving end cover band.
- (3) Similarly remove the two screws securing the commutator cover band.
- (4) Remove the four bolts and locking washers securing the screwed cable union.
- (5) Remove the seven bolts and washers holding the two sections of the end cover.

19. At the commutator end:—

- (1) Unlock and unscrew the four nuts securing the outer bearing cap.
- (2) Remove the cap, reservoir felt, gasket, plain felt washer and outer felt retaining disc.

20. To remove the driving end frame together with the armature:—

- (1) Unlock the tab washers and remove the bolts holding the end frame to the yoke.
- (2) Lift the brushes from the brush boxes.
- (3) Tap the armature with a hide-faced hammer to free the end frame from the yoke.
- (4) Lift out the armature and end frame together.

21. Without removing the bearings from the shaft, clean them out and examine them. If they are considered satisfactory for further use, they should be re-lubricated.

22. Faulty bearings should be removed from the shaft, using the two special bearing extractors (Stores Ref. 5UA/4501 for the driving end, and Stores Ref. 5UA/4502 for the commutator end). Bearings removed from the shaft should not be used again, as extraction is liable to damage the races.

23. ◀When removing the driving end bearing, care must be taken not to damage the splines during removal of the bearing clamping nut. The nut may conveniently be removed as follows:—

- (1) Using a  $\frac{1}{8}$  in. drill, which has had the flutes ground off  $\frac{1}{4}$  in. back from the point, drill out the peening.
- (2) Fit an adapter (*para. 24*) over the splined shaft, with teeth entering the end of the clamping nut.
- (3) Using the adapter to hold the shaft, unscrew the clamping nut. As the nut is turned, the teeth on the adapter will help to remove the peening.
- (4) When the clamping nut is completely unscrewed, remove it together with the adapter.

#### Adapter

**24.** The adapter mentioned in *para. 23* may be made up locally from an unserviceable gearbox coupling as illustrated in *fig. 6*. ▶

#### Lubrication

**25.** Saturate the felt pads with oil OM-170 (Stores Ref. 34B/100553), removing all surplus oil before assembly, care being taken to ensure that the felt pads at the driving end are slightly above the top of the well.

#### Brushes and brush gear

**26.** Brush length when new is 0.735 in., and the minimum permissible brush length is 0.42 in.; new brushes should be fitted if the rate of wear indicates that this length may be reached before the next servicing examination. Brushes must be an easy sliding fit in their holders, and the spring pressure should be maintained at 17 to 19 oz. Ensure that the brushes are bedded over the full thickness of the brush and over at least 80 per cent of the axial width.

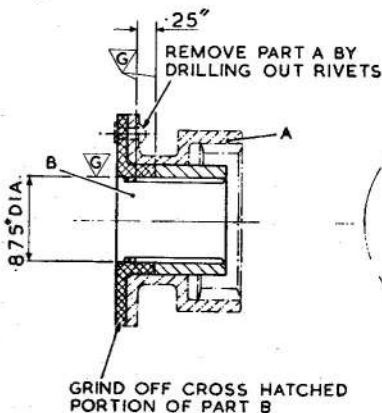

MODIFICATION TO GEARBOX COUPLING

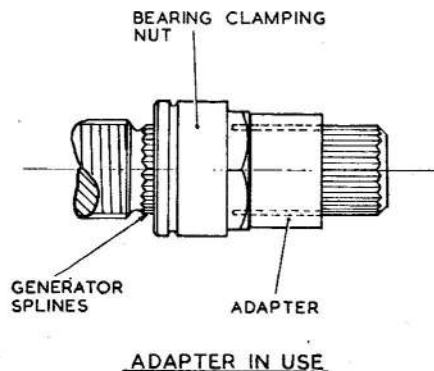
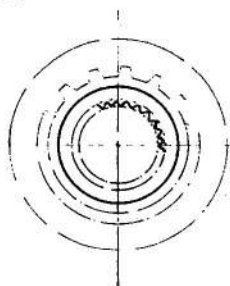

ADAPTER IN USE

Fig. 6. Adapter

#### TESTING

**27.** Before installing a new or a serviced generator, the machine should be tested as laid down in the following paragraphs, using a suitable test set. If the generator fails to function correctly and the fault cannot be located and corrected, normal defect action should be taken.

**28.** The armature should revolve freely, without any fouling of the fixed parts nor excessive end play in the bearings. A slight radial play which can just be felt by the hand is permissible.

#### Polarity

**29.** Run the generator in the correct direction of rotation, with a suitable moving coil voltmeter connected across the output terminals. The meter readings should confirm the terminal marking. It should be remembered that with a centre zero meter there is a possibility of confusion when reading the polarity.

#### Performance

**30.** With the generator connected in the appropriate test circuit, run up on no load to approximately 3,250 r.p.m. There should be no hesitation in build up, and the correct voltage should be attained.

**31.** Run at the same speed on half load for ten minutes. During this run, there should be no more than pin-point sparking at the brushes. At the end of the test the brushes should still slide freely in their boxes.

#### Insulation

**32.** Whilst the generator is still hot from the preceding test the resistance of all live parts together to frame, measured with a standard insulation resistance tester, should be not less than 0.1 megohm.

This file was downloaded  
from the RTFM Library.

Link: [www.scottbouch.com/rtfm](http://www.scottbouch.com/rtfm)

Please see site for usage terms,  
and more aircraft documents.

