

Now 113B-0221-1

### Chapter 1

## GENERATORS, ROTAX B2600 SERIES

### LIST OF CONTENTS

	<i>Para.</i>		<i>Para.</i>
<i>Introduction</i> ....	1	<i>Operation</i> ....	11
<b>Description</b> ....	2	<i>Generators in parallel</i> ....	13
<i>Brushgear</i> ....	5	<b>Installation</b> ....	14
<i>Suppression</i> ....	6	<b>Servicing</b> ....	15
<i>Cooling</i> ....	8	<i>Brushgear</i> ....	16
<i>Electrical connections</i> ....	10	<i>Lubrication</i> ....	18
		<i>Testing</i> ....	19

### LIST OF ILLUSTRATIONS

	<i>Fig.</i>
<i>Sectional view of typical generator</i> ....	1
<i>Diagram of internal connections</i> ....	2

### LIST OF APPENDICES

	<i>App.</i>
<i>Standard serviceability test for generators, Rotax B2600 series</i> ....	A
<i>Generator, Type 551 (Rotax B2601/1)</i> ....	1
<i>Generator, Type 551A (Rotax B2602/1)</i> ....	2
<i>Starter generator, Type 552 (Rotax B2603)</i> ....	3

#### Introduction

1. Generators in the B2600 series are 112V d.c., 22.5 kW, six-pole shunt-wound machines with compensating, interpole and decomposing windings. Details of differences between the various types are given in the Appendices at the end of this chapter.

#### DESCRIPTION

2. A typical generator in the series is illustrated in fig. 1. The machine is of conventional design, having the armature supported in a ball bearing at the driving end and a roller

bearing at the commutator end. An oil seal at the drive end prevents the ingress of oil.

3. Fixed externally to the commutator end frame and connected in parallel with the interpole bias winding is a 1-ohm variable diverter resistor, which is adjusted on test to produce the required degree of commutation.

4. Excitation is provided by a negatively compounded shunt winding, designed to operate in conjunction with a voltage regulator, Type 91 (Ref. No. 5UC/5522). The voltage is maintained between the limits of 109.2 and

RESTRICTED

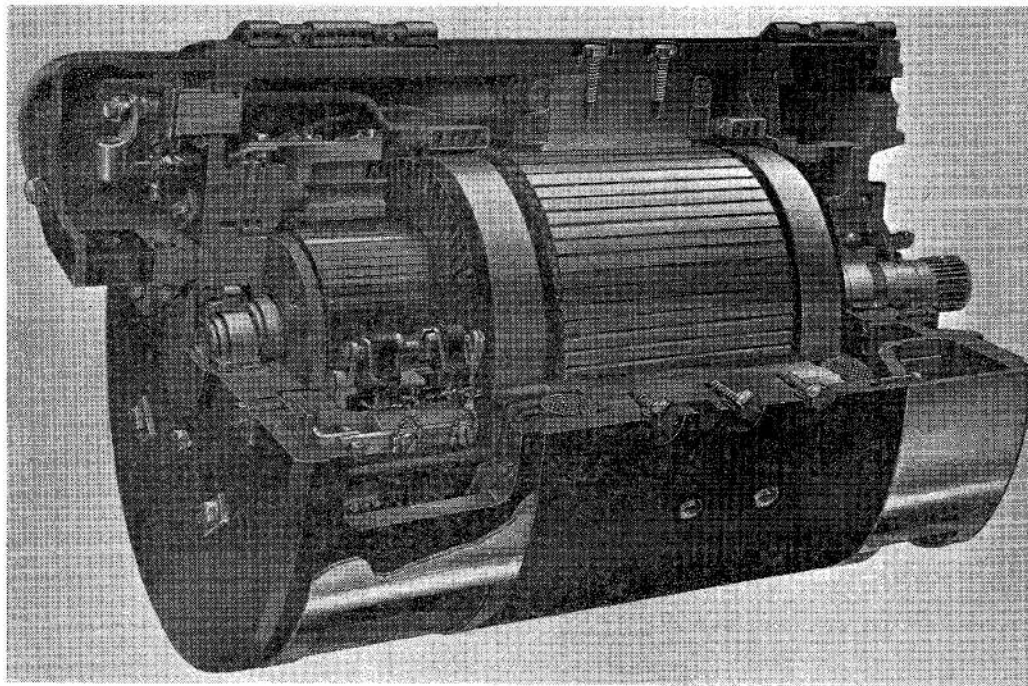

**Fig. 1. Sectional view of typical generator**

114.8 volts at any load up to rated load, at any speed between the minimum of 2,860 r.p.m. and the maximum of 10,000 r.p.m.

#### **Brushgear**

5. The brushgear consists of a ring having six arms, each carrying two brushes. The brush ring mounting flange contains elongated slots which enable the brushgear to be adjusted to obtain relatively sparkless commutation.

#### **Suppression**

6. The windings in series with the armature are split, one half being connected to each output terminal. Suppression of radio interference is effected by the provision of a 0.5  $\mu$ F capacitor between each output terminal and the frame. One 0.5  $\mu$ F capacitor is also connected between the shunt field winding and the frame.

7. The three capacitors are externally fixed and individually recessed into the commutator end frame. A detachable cover provides protection for both the capacitors and terminals. A 10-amp. fuse between terminal 1 and its associated capacitor gives protection in the event of this capacitor short-circuiting.

#### **Cooling**

8. Air blast cooling at 6 in. head of water is employed. This will be satisfactory with rated output at any speed within the specified range and at altitudes up to 50,000 ft.

9. Cooling air requirements for various inlet temperatures are as follows:—

<i>Inlet temperature (deg. C)</i>	<i>Weight of air (lb./min.)</i>
+70	25.8
+50	20.0
+30	16.4
+10	13.9
-10	12.0
-30	10.7

#### **Electrical connections**

10. Terminals are arranged to suit individual requirements. The main terminals use 0.375 in. dia. B.S.F. cable lugs, and 2 B.A. cable lugs provide the connection for the auxiliary terminals.

#### **Operation**

11. The generator will give a d.c. output of 200 amp. at 112 volts, without interruption,

**RESTRICTED**

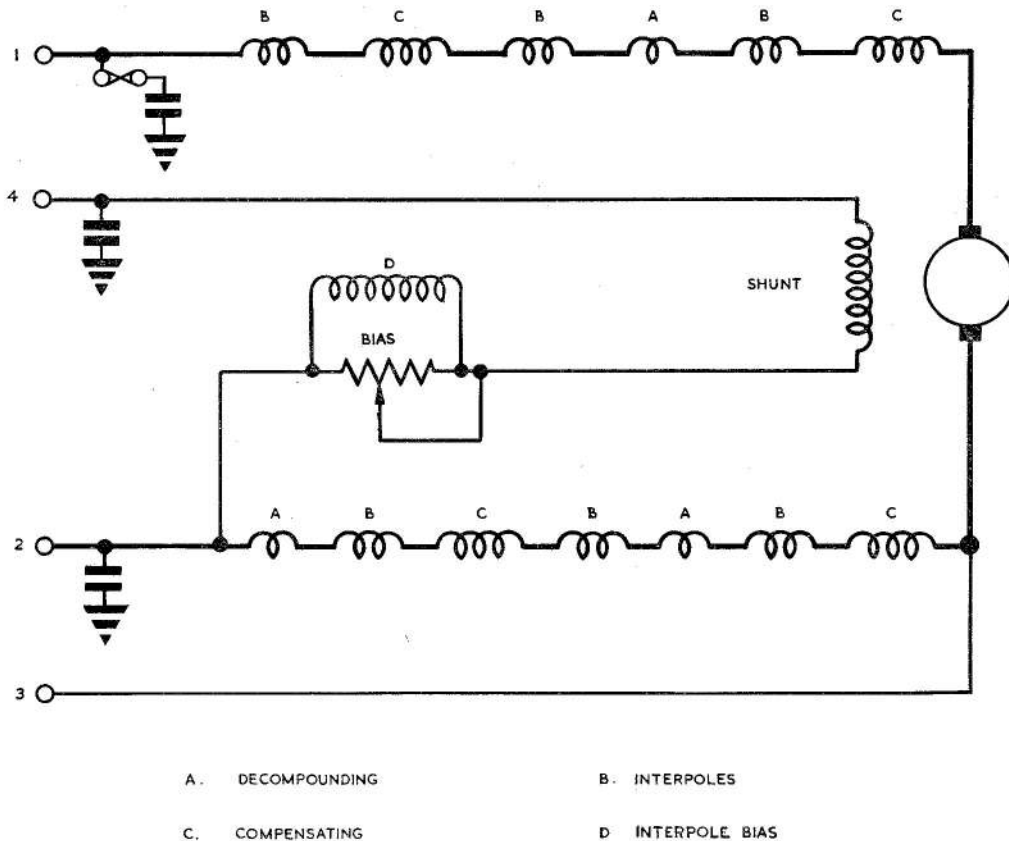

**Fig. 2. Diagram of internal connections**

sudden voltage variation or disturbance to the system when the speed is varied from minimum to maximum or vice versa at any altitude up to 50,000 ft.

12. Operation of the generator is that of a shunt-wound, self-excited machine. With variation of the load and speed, the terminal voltage of the generator would vary considerably, and therefore to maintain a constant output, a Type 91 voltage regulator is fitted in the field circuit.

#### *Generators in parallel*

13. Up to six generators may be connected in parallel with a 48-cell lead-acid battery. The generators will operate satisfactorily within the specified range, and there will be no tendency to hunt when the system is disturbed by sudden variation of speed and load. During parallel

operation, the voltage drop across the equalizing series coil will be between 2.1 and 2.8 volts.

#### **INSTALLATION**

14. Designed to be driven by the aircraft engine via a gearbox mounted on the generator flange, the generator is cradle mounted and may be mounted with the centre line in any axis. For details of a particular installation, reference should be made to the relevant Aircraft Handbook.

#### **SERVICING**

15. Full repair information will be found in Vol. 6 of this publication. General information on the servicing of generators is given in A.P.4343, Vol. 1, Sect. 2, Chap. 1, which should be read in conjunction with the following paragraphs and the relevant Servicing Schedule.

**RESTRICTED**

It will found that the rig described in A.P. 4343S, Vol. 1, Book 2, Sect. 13, Chap. 2 will facilitate the handling of these generators.

#### **Brushgear**

16. Access to the brushgear is gained by removal of the cover band. Brushes should be renewed at periods prescribed in the relevant Servicing Schedule, and whenever examination reveals that they will not remain serviceable for the period that must elapse before the next servicing. If new brushes have been fitted, they should be bedded to the surface of the commutator as laid down in A.P.4343, Vol. 1, Sect. 1, Chap. 2. Check that brushes slide freely in their boxes.

17. The brush spring pressure, measured at the point where the heel of the spring leaves the top of the brush box, should be between 25 and 29 oz. (709 and 822 gm.).

#### **Lubrication**

18. The bearings are pressure-filled on manufacture with grease XG-277, and the bearing cap cavity filled 2/3 full.

#### **Testing**

19. If the serviceability of the machine is suspect, it may be tested as laid down in Appendix A.

**RESTRICTED**

## Appendix A

## STANDARD SERVICEABILITY TEST FOR GENERATORS,

## ROTAX, B2600 SERIES

**Introduction**

1. The following tests may be applied to the machine before it is put into service, or at any time when its serviceability is suspect.

**Test equipment**

2. The following test equipment is required:—

(1) Tester, generator—one in the Mk. 5 series.

(2) Panel, testing (Ref. No. 5G/2925) (if available)

or  
Ammeter, 0—50A d.c.  
Voltmeter, 0—150V d.c.  
40A load resistance

(3) Voltage regulator, Type 91 (Ref. No. 5UC/5522).

(4) Trimmer resistor, Type 7, 40-ohm,  $7\frac{1}{2}$ W (Ref. No. 5UC/5523).

(5) Balance spring, 0—4 lb. (Ref. No. 1H/97).

(6) Insulation resistance tester, Type C (Ref. No. 5G/152).

(7) Insulation resistance tester, Type A (Ref. No. 5G/1621).

**Note . . .**

*If the generator is run with the oil seal fitted, care should be taken to ensure that it is adequately lubricated with the correct grade of engine oil. The generator should also be supplied with adequate cooling air.*

**Testing**

3. Before mounting the generator on the test set, check for freedom of rotating parts by turning the armature by hand. There should be no excessive end play in the bearings; a slight radial play which can just be felt by hand is permissible.

**Brushgear**

4. Check the brush length and brush spring pressure; the brush length should be not less than 0.527 in., and the spring pressure should lie between 25 and 29 oz.

**Polarity**

5. Run the generator in an anti-clockwise direction with a suitable voltmeter across the

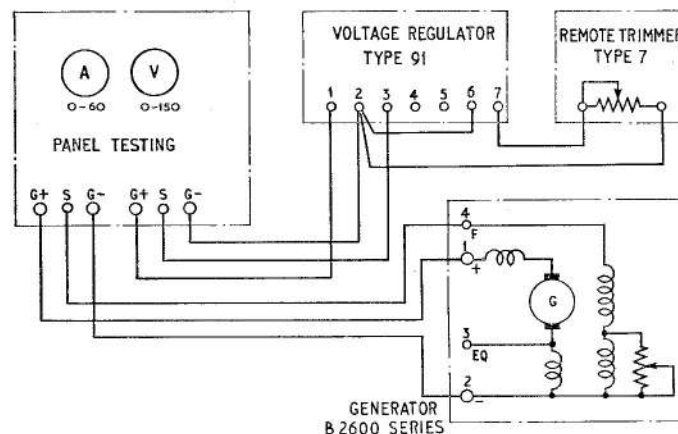

Fig. 1. Test circuit diagram

RESTRICTED

output terminals. The meter reading should confirm the terminal markings.

#### *Performance*

6. With the generator mounted on the test set and connected in the test circuit shown in fig. 1 (using a 40A load and suitable ammeter and voltmeter in place of the testing panel, if necessary), run up on no load to approximately 3,000 r.p.m. There should be no hesitation in build-up, and the correct voltage should be attained.

7. Increase the speed to 6,000 r.p.m., switch on the load and ensure that the load current indicated by the ammeter is 40 amp. Run the generator on load for 30 min., and ensure that there is no more than pin-point sparking at the brushes. At the end of the test the brushes should still slide freely in their boxes.

#### **Note . . .**

*It is undesirable that the shunt field circuit should be switched at high generator speeds, and care should be taken not to inadvertently open and close the shunt field circuit during testing. The shunt field winding is highly inductive and "flashing over" can result.*

#### *Insulation resistance test*

8. Disconnect the 0.5 uF interference suppression capacitors. Using an insulation resistance tester, Type A, the insulation resistance, measured between the main terminals and the frame with the machine still warm, should not be less than 100,000 ohms.

9. Using an insulation resistance tester, Type C, the insulation resistance between the capacitor leads and the frame should be measured and should not be less than 1 megohm.

10. The interference suppression capacitors should then be reconnected.

**RESTRICTED**

## Appendix 1

## GENERATOR, TYPE 551 (ROTAX B2601/1)

## LEADING PARTICULARS

<b>Generator, Type 551</b> .....	Ref. No. 5UA/7440
<i>Output</i> .....	112V, 200A, 22.5 kW
<i>Speed range</i> .....	2,860—10,000 r.p.m.
<i>Rotation (drive end)</i> .....	Anti-clockwise
<i>Lubricant</i> .....	Grease XG-277
<i>Brush grade</i> .....	P.E.G.11
<i>Brush spring pressure</i> .....	25—29 oz.
<i>Brush length (new)</i> .....	1.196 in.
<i>Brush length (minimum permissible)</i> .....	0.527 in.
<i>Commutator diameter (new)</i> .....	3.875 in.
<i>Commutator diameter (minimum permissible)</i> .....	3.800 in.
<i>Overall dimensions—</i>	
<i>Length from flange front</i> .....	18.062 in.
<i>Length from drive shaft to flange</i> .....	2.500 in.
<i>Maximum body diameter</i> .....	10.000 in.
<i>Weight</i> .....	138 lb.

1. The generator, Type 551 (Rotax B2601/1) is similar to that described and illustrated in the main chapter, being a cradle mounted machine.

2. The Type B2601/1 differs from the earlier B2601 (Ref. No. 5UA/5505) in that major components have been re-designed to incorporate an improved type of insulation throughout the complete machine. The reason for these changes is to prevent short-circuits to earth, and between armature and stator field windings.

3. The B2601 generator is now superseded by the B2601/1, introduced by the embodiment of Mod. Elec. A/325, the salient points of which are as follows:—

## (1) Armature—

(a) The commutator end windings and conductors have been processed by the "Trickle Resin System" to prevent ingress of carbon dust into the area behind the commutator risers, and around the commutator banding ring.

(b) Preformed box insulation has been incorporated on all conductors in the

armature slots, and a commutator hub insulation cap introduced between the commutator and the bearing.

## (2) Brushgear—

(a) Plaskon Alkyd insulation has been incorporated under the brush boxes, and Inconel brush springs have been introduced to a new brushgear assembly.

## (3) Yoke and field coils assembly—

(a) Preformed box insulation has been incorporated in the interpole and pole-shoe assemblies, and additional insulation has been added between the shunt, bias, and decompounding windings.

(b) The shunt and bias coil connections have been re-routed to prevent high potential conductors shorting to low potential conductors; this has reduced carbon dust pockets to a minimum with improved cooling.

(c) The yoke and field coils assembly has been treated with anti-tracking paint to prevent surface tracking.

(d) The series winding conductors have been changed from three per pole to one per pole to strengthen the field coil winding brazed connections.

RESTRICTED

○

○

○

○

## Appendix 2

## GENERATOR, TYPE 551A (ROTAX B2602/1)

## LEADING PARTICULARS

Generator, Type 551A	....	....	....	Ref. No. 5UA/7441
Output	....	....	....	112V, 200A, 22.5 kW
Speed range....	....	....	....	2,860—10,000 r.p.m.
Rotation (drive end)	....	....	....	Anti-clockwise
Lubricant	....	....	....	Grease XG-277
Brush grade....	....	....	....	P.E.G.11
Brush spring pressure	....	....	....	25—29 oz.
Brush length (new)	....	....	....	1.196 in.
Brush length (minimum permissible)	....	....	....	0.527 in.
Commutator diameter (new)	....	....	....	3.875 in.
Commutator diameter (minimum permissible)	....	....	....	3.800 in.
Overall dimensions—				
Length from flange front	....	....	....	16.142 in.
Length from drive shaft to flange	....	....	....	2.500 in.
Maximum body diameter	....	....	....	10.000 in.
Weight	....	....	....	138 lb.

1. The generator, Type 551A (Rotax B2602/1) (fig. 1 and 2) is generally similar to that described and illustrated in the main chapter, but differs in that it is flange mounted and spigot located. The terminal block assembly is mounted on the outside diameter of the commutator end frame, and the suppression capacitors and inter-pole bias resistor on the inside of the unit. The terminal arrangement is shown in fig. 3.

2. The Type B2602/1 differs from the earlier B2602 (Ref. No. 5UA/6676) in that major components have been re-designed to incorporate an improved type of insulation throughout the complete machine. The reason for these changes is to prevent short circuits to earth, and between armature and stator field windings.

3. The B2602 generator is now superseded by the B2602/1 introduced by the embodiment of Mod. Elec. A/325, the salient points of which are as follows:—

(1) Armature—

(a) The commutator end windings and

conductors have been processed by the "Trickle Resin System" to prevent ingress of carbon dust into the area behind the commutator risers, and around the commutator banding ring.

(b) Preformed box insulation has been incorporated on all conductors in the armature slots, and a commutator hub insulation cap introduced between the commutator and the bearing.

(2) Brushgear—

(a) Plaskon Alkyd insulation has been incorporated under the brush boxes, and Inconel brush springs have been introduced to a new brushgear assembly.

(3) Yoke and field coils assembly—

(a) Pre-formed box insulation has been incorporated in the interpole and pole-shoe assemblies, and additional insulation has been added between the shunt, bias, and decompounding windings.

(b) The shunt and bias coil connections have been re-routed to prevent high potential conductors shorting to

RESTRICTED

low potential conductors; this has reduced carbon dust pockets to a minimum with improved cooling.

(c) The yoke and field coils assembly have been treated with anti-tracking paint to prevent surface tracking.

(d) The series winding conductors have been changed from three per pole

to one per pole to strengthen the field coil winding brazed connections.

#### Installation

4. This machine is flanged mounted, and should be mounted with the terminal block below in the horizontal centre line.

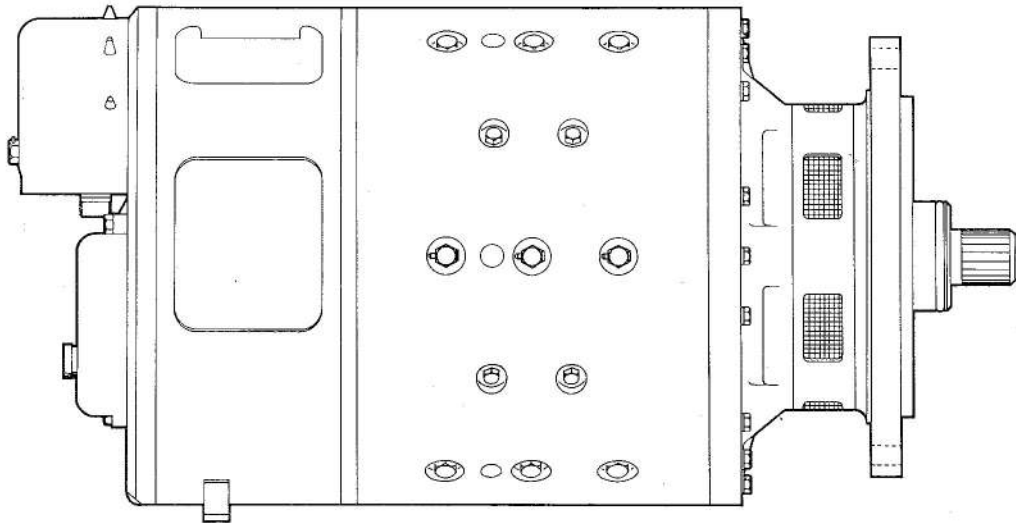

Fig. 1. Side elevation of 551A generator

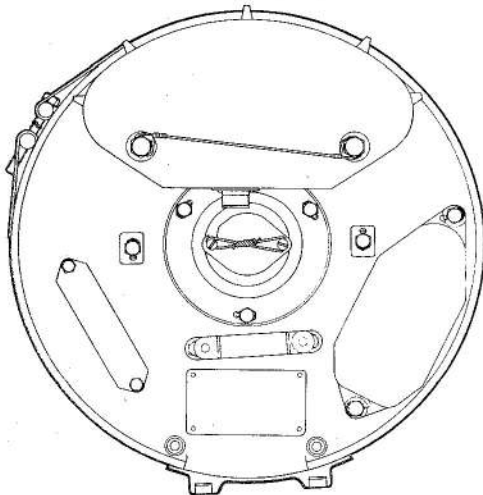

Fig. 2. End elevation showing fuse holder

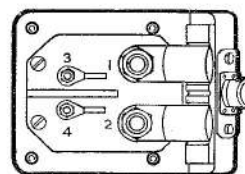

Fig. 3. Terminal arrangement

**RESTRICTED**

## Appendix 3

## STARTER GENERATOR, TYPE 552 (ROTAX B2603)

## LEADING PARTICULARS

Starter generator, Type 552	.....	.....	.....	Ref. No. 5UA/6454
Output	.....	.....	.....	112V, 200A, 22.5 kW
Speed range	.....	.....	.....	2,860-10,000 r.p.m.
Rotation (drive-end)	.....	.....	.....	Anti-clockwise
Lubricant	.....	.....	.....	Grease XG-277
Brush grade	.....	.....	.....	P.E.G. 11
Brush spring pressure	.....	.....	.....	25-29 oz.
Brush length (new)	.....	.....	.....	1.196 in.
Brush length (minimum permissible)	.....	.....	.....	0.527 in.
Commutator diameter (new)	.....	.....	.....	3.875 in.
Commutator diameter (minimum permissible)	.....	.....	.....	3.800 in.
Overall dimensions—				
Length from flange front	.....	.....	.....	18.062 in.
Maximum body diameter	.....	.....	.....	10.000 in.
Weight	.....	.....	.....	138 lb.

1. The starter generator, Type 552 (fig. 1) is a modified version of the Type 551 generator the differences are that cable cleats are fitted to the commutator end frame (fig. 2), and there

has been an alteration in the driving end dimensions. It is not interchangeable with the other generators in this series.

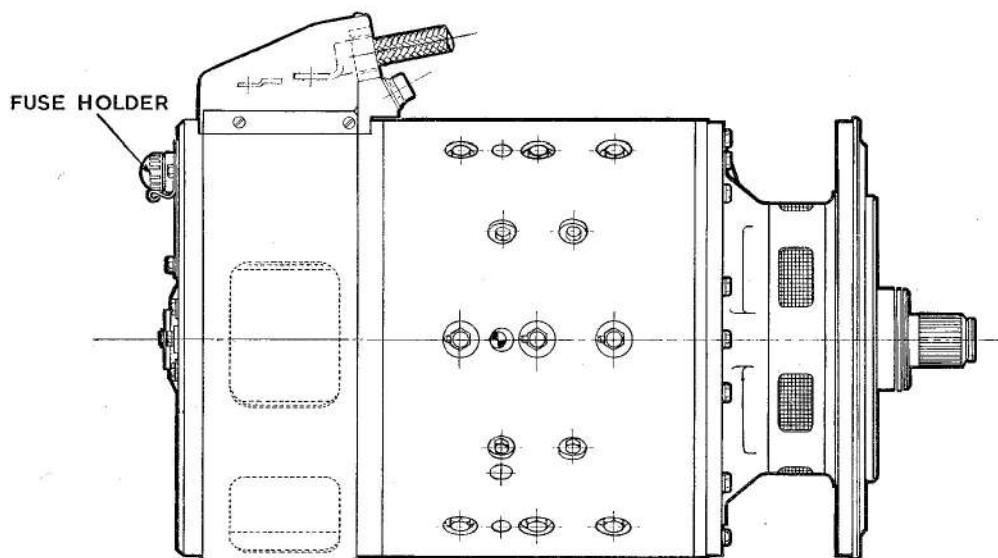

Fig. 1. Side elevation of starter generator, Type 552

RESTRICTED

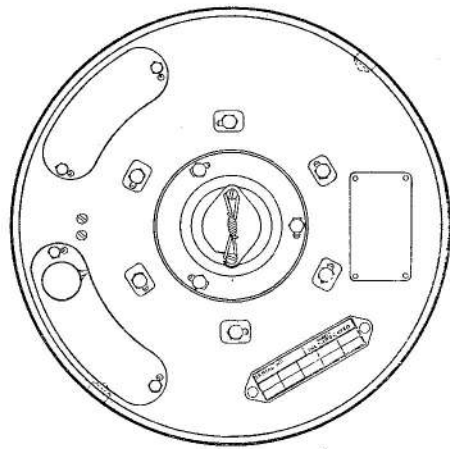

Fig. 2. End elevation, showing cable cleats

This file was downloaded  
from the RTFM Library.

Link: [www.scottbouch.com/rtfm](http://www.scottbouch.com/rtfm)

Please see site for usage terms,  
and more aircraft documents.

