

*Obsolete*

## Chapter 2

### GENERATOR, TYPE UO

#### LIST OF CONTENTS

	Para.		Para.
Introduction	1	Installation	11
Description		Servicing	
General	2	General	14
Bearings and lubrication	3	Lubrication	15
Cooling	4	Testing	16
A.C. section	5	A.C. section	18
D.C. section	8	D.C. section	19

#### LIST OF ILLUSTRATIONS

	Fig.		Fig.
General view from driving end	1	Lubrication system—commutator end	6
General view from commutator end	2	Diagram of external d.c. circuit connections for clockwise rotation of generator	7
Sectional view of generator	3	Diagram of external d.c. circuit connections for anti-clockwise rotation of generator	8
Diagram of internal wiring	4		
Lubrication system—driving end	5		

#### LEADING PARTICULARS

<b>Generator, Type UO</b>	
Stores Ref. ...	5U/2362
Output (a.c.) ...	80 volts, 15 amp., 1,200—2,400 cycles per sec.
Output (d.c.) ...	30 volts, 100 amp.
Speed range (continuous operation) ...	3,000—6,000 r.p.m.
Max. speed (for 5 min. only) ...	7,500 r.p.m.
Weight ...	52 lb.
Brushes ...	Grade EGO (H.A.M.) Stores Ref. 5U/4169
Brush spring pressure ...	18—22 oz.
Lubricant ...	Oil OM—170 (Stores Ref. 34A/60)
Resistance of windings ( $\pm 10$ per cent at 20 deg. C.)	
Armature ...	0.04 ohm
Shunt field ...	2.9 ohms
Exciter coil ...	7.2 ohms
Stator winding ...	0.17 ohm
Compensating winding ...	0.03 ohm
Voltage regulator (for d.c. output) ...	Type J2 (Stores Ref. 5U/2573)
Suppressor (for d.c. output) ...	Type W (Stores Ref. 5C/1614)
	or Type W2 (Stores Ref. 5C/3001)
Regulation (for a.c. output) ...	Control panel, Type 5 (Stores Ref. 5U/363)
	or Control panel, Type 5A (Stores Ref. 5U/3783)
Switchboard for testing	
a.c. output ...	Type K (Stores Ref. 5G/214)
	used with loading panel (Stores Ref. 5G/215)
d.c. output ...	Type E (Stores Ref. 5G/196)
	used with loading panel (Stores Ref. 5G/197)

**RESTRICTED**

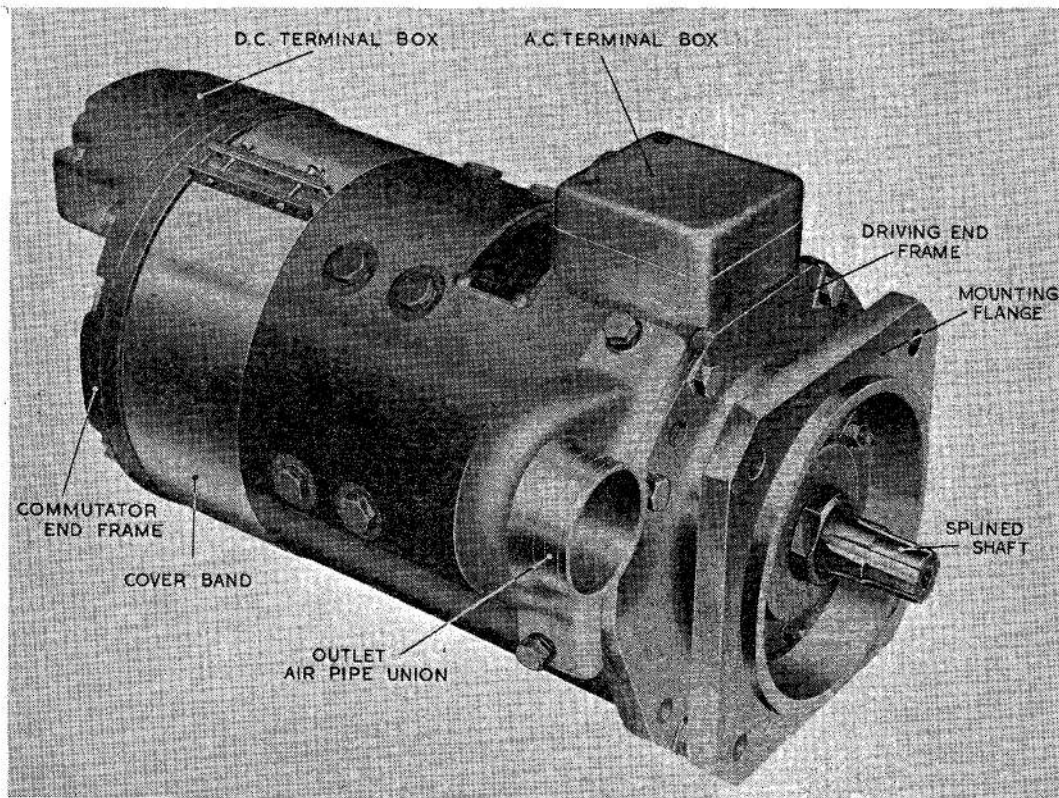

Fig. 1. General view from driving end

#### Introduction

1. Generator, Type UO, is a dual purpose machine, giving a.c. and d.c. outputs. It is engine driven and may be operated in either direction of rotation without adjustment of the brush position. The output voltages are controlled by suitable voltage regulators acting on the shunt field circuit of the d.c. section and on the exciting winding of the a.c. section.

#### DESCRIPTION

##### General

2. Generator, Type UO, generates both a.c. and d.c. The a.c. stator windings and exciter coil and the d.c. field and compensating windings are enclosed in a common yoke. The a.c. rotor and the d.c. armature are mounted on a common shaft, but the two sections are electrically separate.

##### Bearings and lubrication

3. The shaft is carried on two oil lubricated bearings, one located in the driving end frame, and the other free to slide in an annular recess in the commutator end frame. Lubri-

cation is effected in the following way. An oil soaked reservoir, in the form of felt washers, is housed in each outer and inner bearing cap. A felt washer, making light rubbing contact on the shaft, and also in contact with the main reservoir, is attached to a thin metal disc and assembled on the outer and inner side of each bearing. The metal disc, being adjacent to the bearing, prevents the felt being drawn into the bearing and causing failure. Oil is transferred from the main reservoir by the felt wiping washer to the shaft and passes into the bearing by centrifugal force as the shaft rotates.

##### Cooling

4. Cooling is normally effected by air from the slipstream, but where the generator is mounted in a ground test set, an air blower is provided. The inlet air pipe is situated on the commutator end frame. Air is circulated over the brush gear assembly and commutator, through the yoke, and emitted through the air pipe union on the yoke at the driving end. Alternative positions are provided for the air pipe unions. It should

**RESTRICTED**

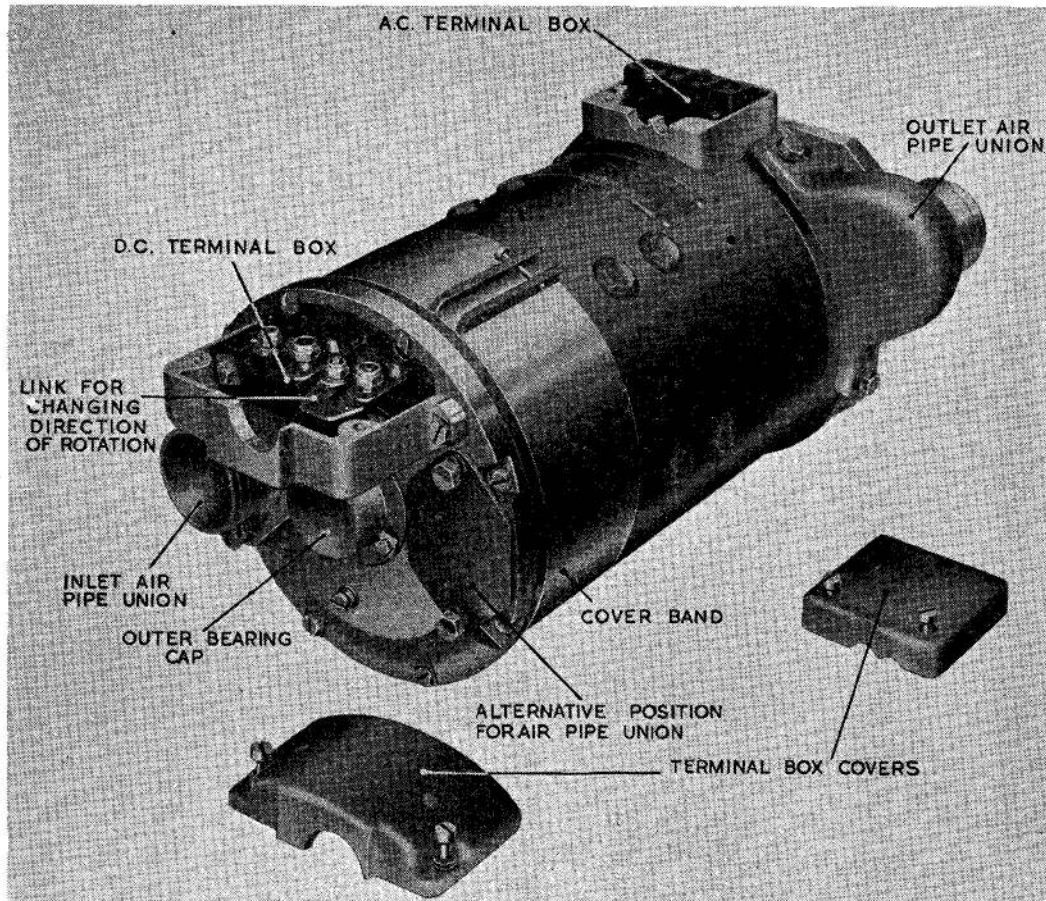

Fig. 2. General view from commutator end

be noted that the air pipe union at the driving end cannot be reversed as the fixing holes are not symmetrically placed in the mounting face.

#### A.C. section

5. The principle of operation of the a.c. section of the generator is discussed in A.P.4343, Vol. 1, Sect. 2. The excitation voltage is 24-29 and the frequency of the a.c. output, which is proportional to the speed of rotation, is 1,200 cycles per second at 3,000 r.p.m. The arrangement of the a.c. winding and the excitation winding is shown in fig. 4. The a.c. output is unaffected by change in direction of rotation of the generator.

6. The a.c. terminal box is mounted on the yoke of the generator near the driving end frame. The box contains four terminals

which are arranged as follows. The leads from the a.c. winding are taken to the two outer terminals which are marked yellow and blue. The leads from the exciting winding are to the two middle terminals which are taken marked white and black.

7. A capacitance of  $18\mu\text{F}$  must be connected in series with the a.c. winding. This is provided by a condenser unit incorporated in the control panel, the links on it enabling the correct capacitance to be inserted.

#### D.C. section

8. This section is a self-excited six-pole generator which has both shunt and compensating field windings. The shunt coils are carried on the pole pieces, and the compensating winding is carried in the slots in the faces of the pole pieces and connected

**RESTRICTED**

RESTRICTED

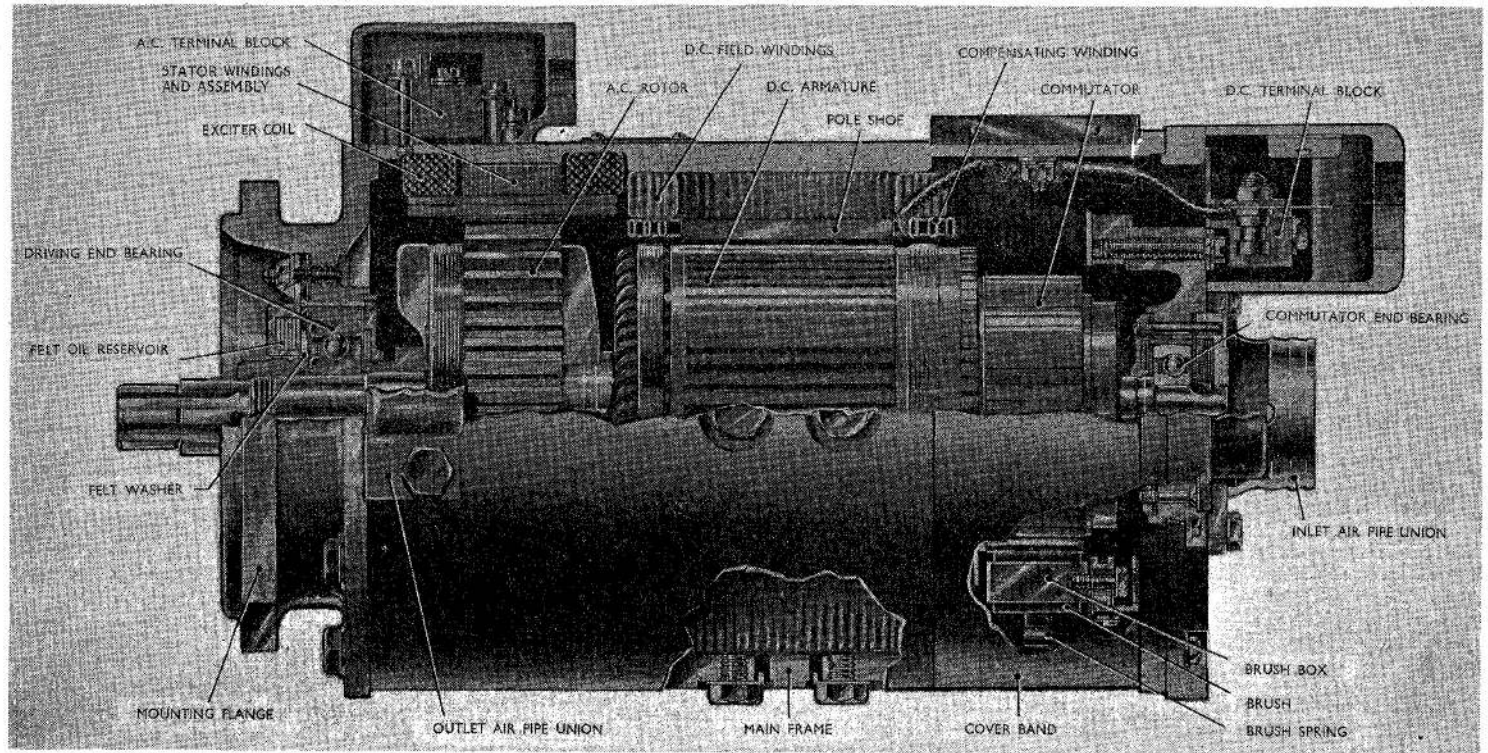

Fig. 3. Sectional view of generator

in series with the armature. The compensating winding prevents distortion of the magnetic field under the pole faces due to the current flowing in the armature conductors. It thus assists in producing satisfactory commutation without moving the brushes from the magnetic neutral position.

9. The d.c. terminal block is mounted on the commutator end frame, and has four terminals. A special arrangement of terminals is provided, to enable the direction of rotation of the generator to be reversed. Looking at the d.c. terminal block from the commutator end of the machine, one end of the shunt field winding is attached to the small terminal on the left-hand side; the external field connection is always made to this terminal. The other end of the shunt field winding is attached to the small terminal between the two main terminals. A flat metal link is provided to connect this field terminal to one or other of the main terminals according to the direction of rotation required. The change in rotation is obtained by turning the link over so that the arrow stamped on its upper face indicates the direction of rotation required. It will be seen from fig. 7, which shows the d.c. connection to the voltage regulator for either direction of rotation, that the polarity of the main terminals is reversed when the

direction of rotation is reversed. The main terminal to which the field link is connected is always negative, the free main terminal being positive.

10. The six brushes are mounted 60 deg. apart on the brush rocker which is spigoted on to the commutator end frame and secured to it by two screws. Brush pressure is maintained by flat coil springs. The commutator end frame is secured by screws to the yoke and the brush gear openings are enclosed by a cover band.

**INSTALLATION**

11. The splined end of the shaft protruding beyond the driving end frame should be protected by a ferrule when the generator is not in use. In some installations a coupling member, which is intended to engage with a corresponding member on the engine, is fitted to the generator shaft. With this arrangement, care should be taken to see that the coupling member is a close sliding fit on the shaft, and that it is properly secured by an axial or clamping bolt which should be suitably locked after tightening. In other installations, the generator shaft engages directly with a suitably splined driving member on the engine. In both instances the shaft should first be coated lightly with clean engine oil.

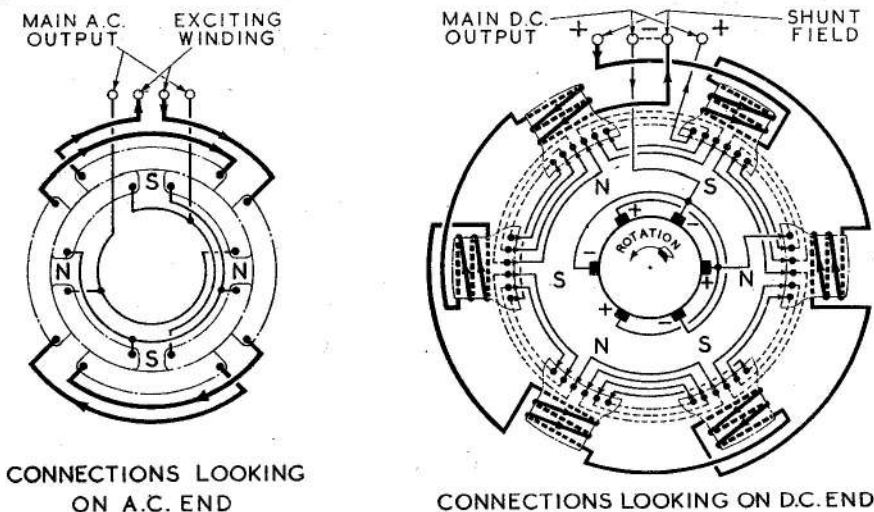

Fig. 4. Diagram of internal wiring

**RESTRICTED**

12. When connecting the cable to the generator, the indicating tag on the field link should be bent down to enable the connection to the terminal to be made without difficulty. This should be done only after checking the direction of rotation of the generator. If the tag is not bent down, there is a likelihood of shorting between the link and the positive terminal.

13. The d.c. output of the generator is controlled by a voltage regulator, Type J2, and the a.c. output by a control panel, Type 5 or 5A. The output voltages are thus maintained at a steady figure, irrespective of fluctuating engine speeds or the load connected to the generator. The link on the condenser in the control panel should be connected to give a capacity of  $18\mu\text{F}$  (refer to A.P.1095C, Vol. 1, Sect. 11, Chap. 1).

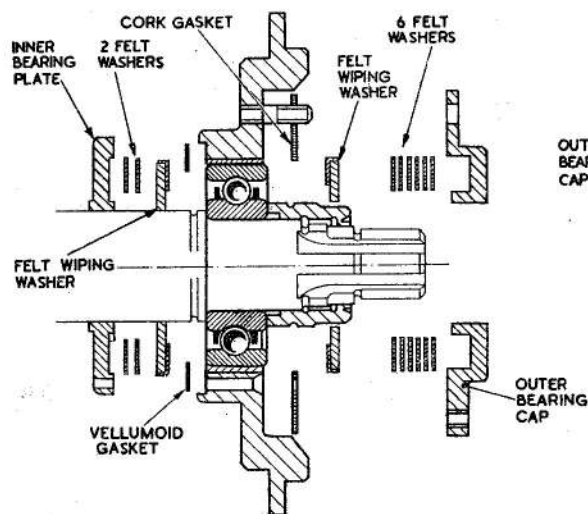

Fig. 5. Lubrication system—driving end

#### SERVICING

##### General

14. The following instructions on servicing are to be read in conjunction with the general information given in A.P.4343, Vol. 1, Sect. 2. The external connections should also be examined for condition and security, and all nuts and fixing screws checked and tightened where necessary. If the generator has to be inspected in the open, care should be taken to prevent the ingress of moisture.

##### Lubrication

15. To lubricate the bearings, the appropriate outer bearing cap must be removed and the felt reservoir soaked in oil OM—170

(Stores Ref. 34A/60). After soaking, the felts should be replaced in their outer bearing caps and a little of the superfluous oil pressed out, depressing the felts lightly with the fingers, afterwards wiping the metal with a piece of clean absorbent cloth. The outer felt retaining discs and wipers should be similarly lubricated. The bearings and the ball race cages must be examined whilst the outer bearings caps and the felt retaining discs and wipers are off.

##### Testing

16. The generator should be connected to a bench test set, Stores Ref. 5C/112, 5C/336, or any similar type, with the appropriate regulators installed. It is essential that the regulators should be correctly set up in accordance with current instructions.

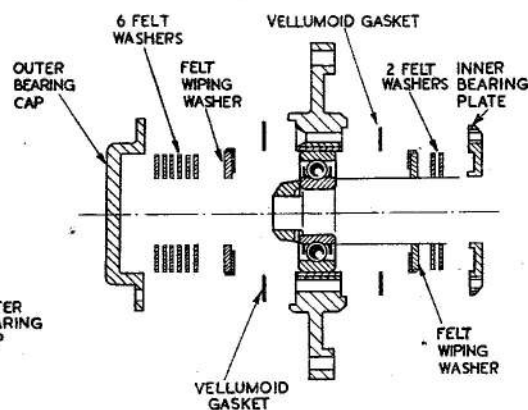

Fig. 6. Lubrication system—commutator end

17. The rotor and armature should rotate freely without excessive friction or shake in the bearings, or contact between the moving and stationary parts. A very small radial play which can just be felt by hand is permissible provided the movement lies within the bearing and not between the bearing and either the shaft or housing.

##### A.C. section

18. Owing to the simplicity of the electrical circuits in this section it is only necessary for satisfactory operation to ensure that there are no open circuits in either the a.c. or exciting windings (a rare occurrence) and that the insulation resistance is satisfactory.

**RESTRICTED**

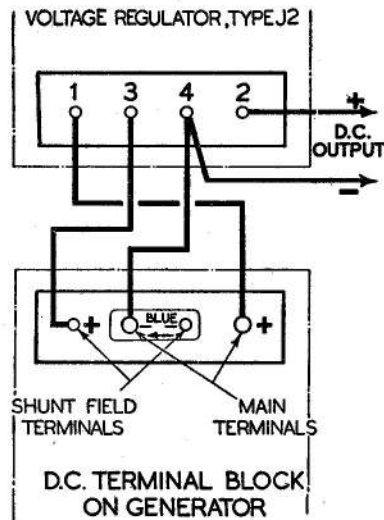

Fig. 7. Diagram of external d.c. circuit connections for clockwise rotation of generator

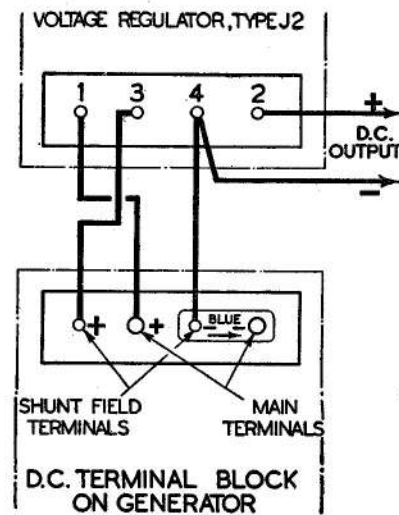

Fig. 8. Diagram of external d.c. circuit connections for anti-clockwise rotation of generator

Connect the generator to the appropriate control panel, the latter being connected to a suitable source of d.c. supply and to a suitable load. Use the switchbox and loading panel quoted in Leading Particulars. Run the generator at approximately 3,000 r.p.m. on half load for 10 minutes. At the end of this period the insulation resistance of all live parts together to the frame should not be less than 0.1 megohm when measured with a 250-volt insulation resistance tester.

**D.C. section**

19. (1) Connect the generator to its appropriate regulators and run at approximately 3,000 r.p.m. on no load. Check that the correct voltage is obtained, that there is no hesitation in build-up, and that the polarity is correct in accordance with the terminal markings at the d.c. end of the machine. A moving coil voltmeter should be used.
- (2) Run at the same speed on half load for 10 minutes. During this run there should be not more than very slight sparking. At the end of this period the fit of the brushes in their boxes should be checked. They should remain free

to slide without any trace of binding.

- (3) With the machine hot, i.e., after test (2), the insulation resistance should be measured with a 250-volt insulation resistance tester. The reading should be not less than 0.1 megohm between the following points:—
  - a.c. winding to d.c. windings (including alternator field) and frame.
  - d.c. windings (including alternator field) to a.c. winding and frame.

**Note . . .**

*The generator should not be run on load for longer than 10 minutes unless some arrangement is made to provide air cooling. Otherwise there will be serious risk of overheating and consequent damage to the generator.*

20. Screws and nuts, tightened prior to these tests, should now be locked where necessary. The tests specified above, together with careful examination during servicing, are sufficient to ensure that the generator gives satisfactory operation.

**RESTRICTED**

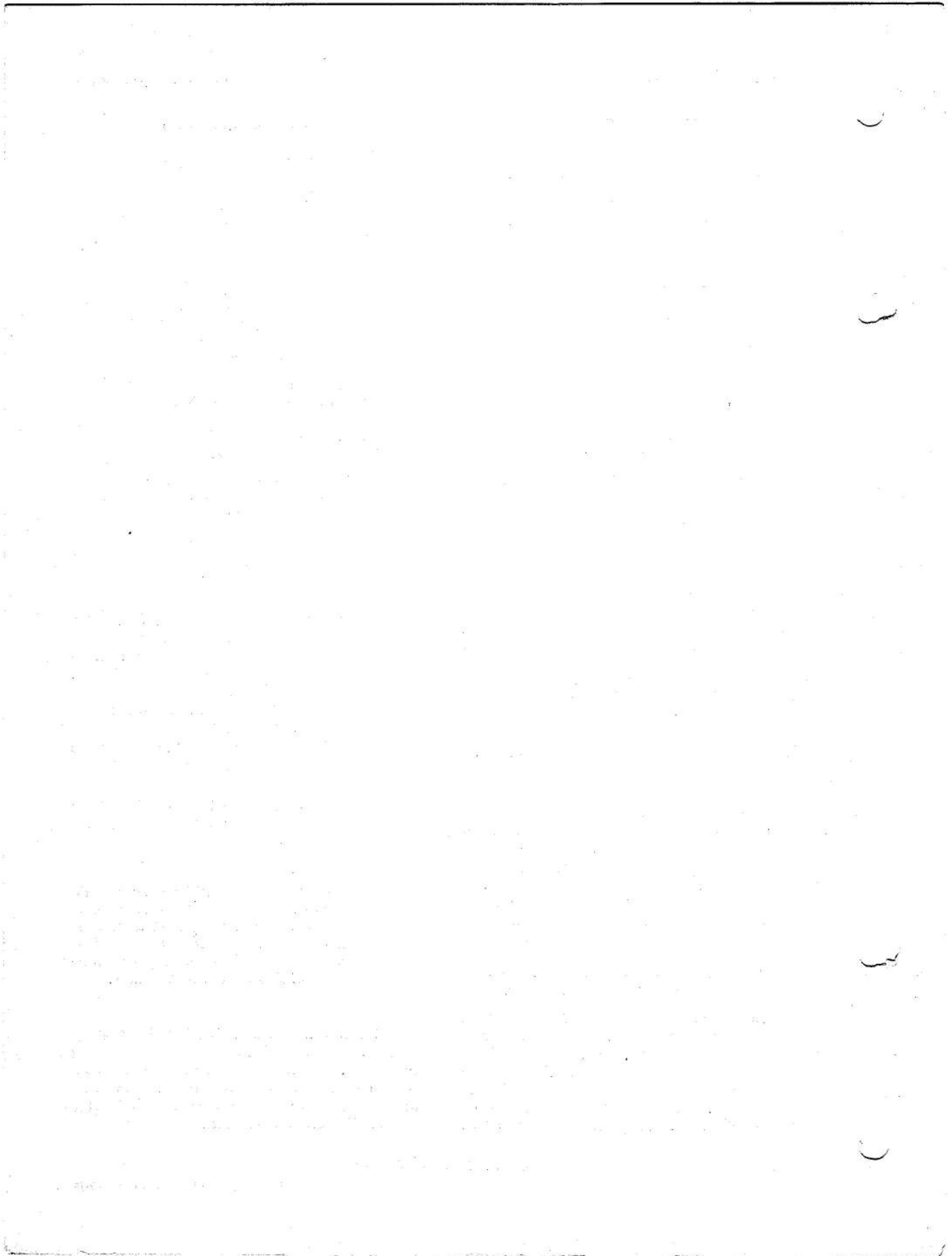

This file was downloaded  
from the RTFM Library.  
Link: [www.scottbouch.com/rtfm](http://www.scottbouch.com/rtfm)

Please see site for usage terms,  
and more aircraft documents.

