

Chapter 12

VOLTAGE REGULATOR, TYPE 108

LIST OF CONTENTS

	Para.		Para.
Introduction	1	Servicing	5
Description	2		

LIST OF ILLUSTRATIONS

	Fig.		Fig.
Voltage regulator, Type 108	1	Circuit diagram	2

LEADING PARTICULARS

Voltage regulator, Type 108	Ref. No. 5UC/6274
Controlled voltage	115 volts \pm 2 per cent a.c.
Maximum pile loading	45 watts
Actual pile loading	25 watts
Pile resistance range	2.2 to 34.5 ohms
Carbon pile	Ref. No. 5UC/
Operating coil current	0.115 to 0.125 amp.
Operating coil resistance	390 ohms cold
Trimmer resistor	180 ohms, 3 watts
Ballast resistor	996 ohms, 40 watts
Stabilizing transformer series resistor	20 ohms, 20 watts
Stabilizing transformer—	
Ratio	1:1
Primary winding	25 ohms
Secondary winding	35 ohms
Dimensions	7.25 in. \times 6 in. \times 5.625 in.

Introduction

1. The voltage regulator, Type 108, is used to control the output of the rotary inverter, Type 111 at 115 volts, 3-phase, 400 c/s a.c.

DESCRIPTION

2. This regulator (*fig. 1*) is of the single carbon pile type, and in general construction and principle of operation is similar to the standard design described in A.P.4343, Vol. 1, Sect. 6, Chap. 1. It incorporates the later flap type armature spring, with a bi-metal

strip embodied for temperature compensation. The pile stack is 2 in. long, and consists of forty-four 1-mm. washers, with a 3-mm. washer at each end.

3. The regulator unit is mounted on a base, beneath which are the associated ballast and trimmer resistors and stabilizing transformer. The trimmer resistor is adjusted by means of a slotted screw on the front of the base plate.

4. A stabilizing transformer is fitted to maintain the stability of the regulator

(A.L.4, Mar. 58)

during sudden speed or load changes, and is connected as shown in the circuit diagram in fig. 2, with its primary winding connected across the inverter field and its secondary in series with the operating coil. Under stable conditions, no voltage is induced in the secondary winding, but when the inverter speed changes, a voltage will be induced in the secondary winding such as to oppose the compensating effect of the operating coil and so damp any tendency towards oscillation.

SERVICING

5. General servicing instructions for this type of regulator are given in A.P.4343, Vol. 1, Sect. 6, Chap. 1. That chapter describes the fitting of a new pile stack, and the preliminary mechanical adjustment for a regulator which is completely out of order. When any adjustment is made, the regulator must afterwards be subjected to full test. Details of the testing procedure will be issued later.

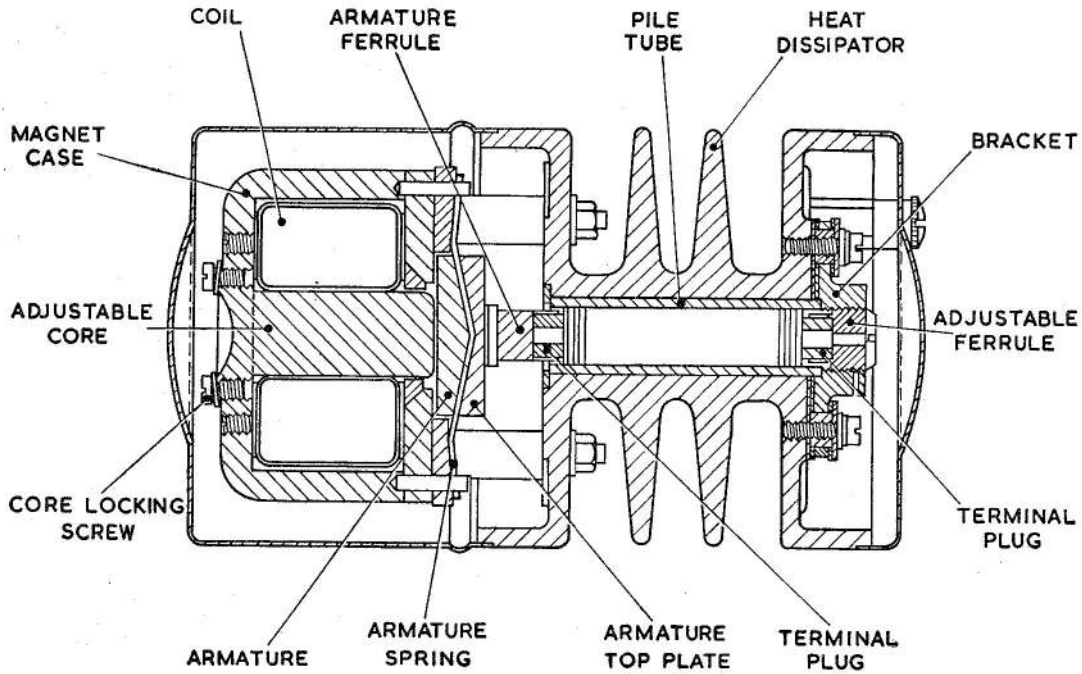

Fig. 1. Voltage regulator, Type 108

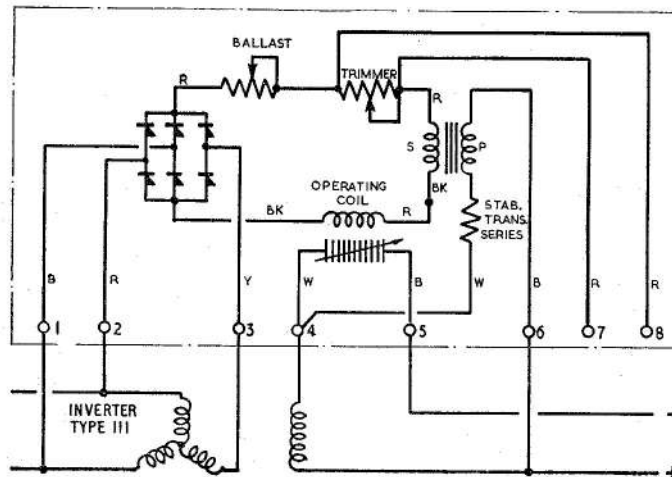

Fig. 2. Circuit diagram

RESTRICTED



This file was downloaded from the RTFM Library.

Link: www.scottbouch.com/rtfm

Please see site for usage terms, and more aircraft documents.

