

Now 113D-07143-1

Chapter 15

VOLTAGE REGULATOR, TYPE EU2

LIST OF CONTENTS

	Para.		Para.
Introduction	1	Regulation test	7
Description	2	Alternative procedure	10
Servicing	4	Stability test	11
Testing	5	Checking a new regulator	14

LIST OF ILLUSTRATIONS

	Fig.		Fig.
Circuit diagram	1	Test circuit diagram	2

LEADING PARTICULARS

Voltage regulator, Type EU2	Stores Ref. 5UC/3886
Coil current 0.31 to 0.34 amp.
Carbon pile	Stores Ref. 5UC/1021
Pile resistance range 5 to 90 ohms
Ballast resistor (300 ohms)	Stores Ref. 5UC/306

Introduction

1. The voltage regulator, Type EU2, is normally fitted to the control panels, Types 5A and 9A. In the Type 5A, it controls the output of the generators, Type U, V, U2, or UO, and in the Type 9A, the output of the inverter, Type RC2. In each instance, the output voltage is maintained constant at 80 volts a.c. (R.M.S.).

DESCRIPTION

2. The regulator, Type EU2, is specially designed for accurate R.M.S. voltage regulation, and for this purpose incorporates a metrosil resistance. The metrosil is a variable resistance with non-linear characteristics giving an instantaneous response to voltage variations in the a.c. output of the generator and provides regulation within very close limits.

3. The carbon pile has a total length of 1.5 in., and is made up of a minimum of 76 washers, each 0.5 mm.

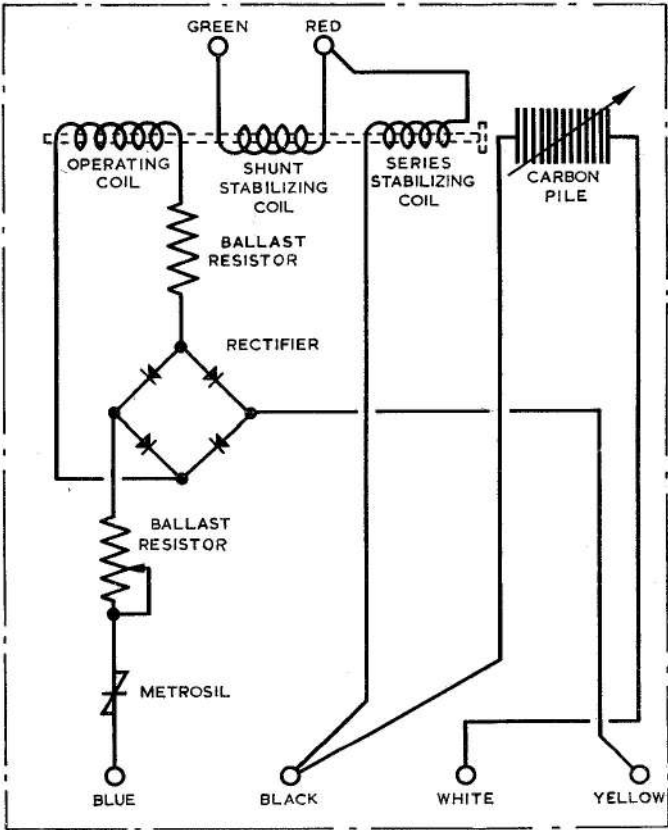

Fig. 1. Circuit diagram

(A.L.I, Aug. 57)

RESTRICTED

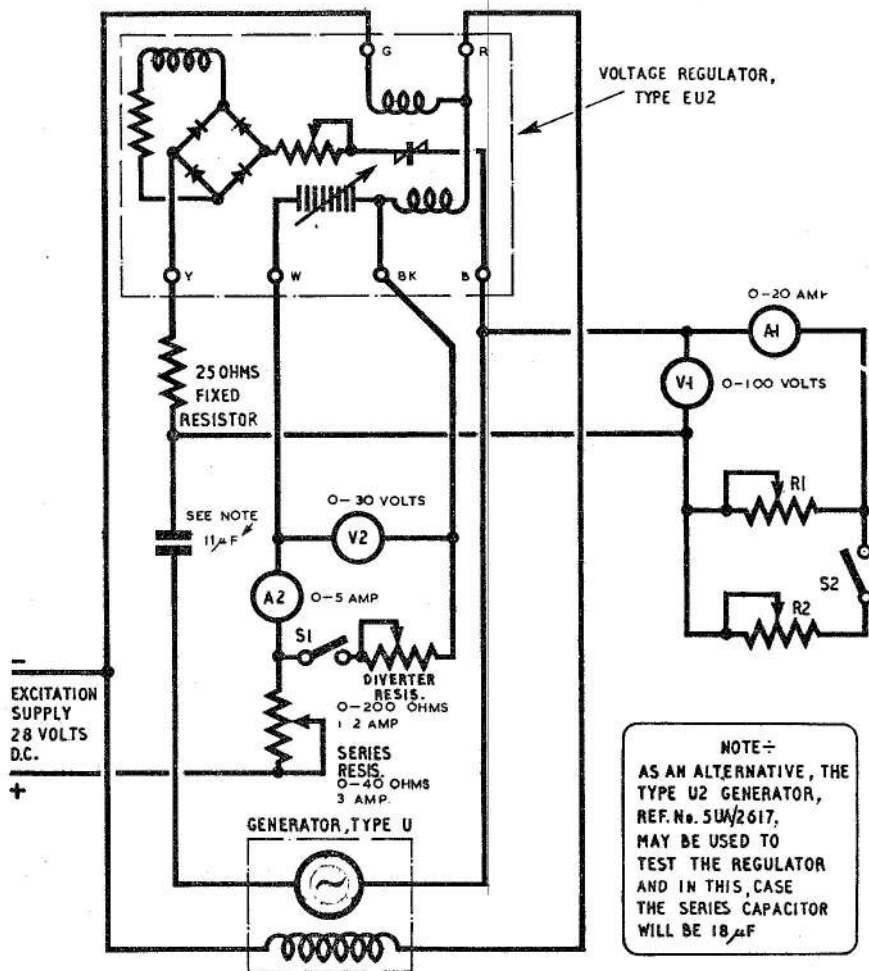

Fig. 2. Test circuit diagram

thick. A circuit diagram is given in fig. 1, and general information on this type of regulator will be found in A.P.4343, Vol. 1, Sect. 6, Chap. 2.

SERVICING

4. General servicing instructions for this type of regulator are given in A.P.4343, Vol. 1, Sect. 6, Chap. 1 and 2. Chap. 1, describes the method of adjusting a regulator which is out of order; if any adjustment is made, the regulator must be fully tested as described in the following paragraphs.

Testing

5. Connect the regulator in the test circuit as shown in fig. 2, the generator used being a Type U (Stores Ref. 5UA/349) or Type U2

(Stores Ref. 5UA/2617) excited from a 28-volt supply. Unless otherwise stated, the speed of the generator is to be maintained at 4,000 r.p.m. for all tests.

6. The currents specified in the regulation and stability tests must be measured at 80 volts a.c. (R.M.S.), and are obtained by setting resistors R1 and R2. The voltmeter V1 must be of the thermal type, and of a range such that the readings required lie between half-scale and full-scale deflection.

Regulation test

7. Adjust the series and diverter resistors so that the pile resistance does not exceed 2 ohms when the generator is running on a load of 15 amp.

RESTRICTED

8. The generator is then to be stopped and re-started, and the pile resistance increased from 2 ohms to 90 ohms and then decreased to 5 ohms, by further adjustment of the series and diverter resistors.

Note . . .

The variation in pile resistance must be made smoothly, and to facilitate this, the diverter resistor must always be switched in and out when at maximum resistance. The series resistor should always be set at 0 ohms except when actually being used to obtain minimum pile resistance.

9. The pile resistance is then to be increased from 5 ohms to 90 ohms and then decreased to 5 ohms, and during this cycle, readings of controlled voltage are to be taken on voltmeter V1. Under these conditions, the regulator should be so adjusted that the readings do not vary by more than 3 volts, and lie between the limits of 78 volts and 83 volts a.c. (R.M.S.). With the regulator adjusted to meet the above requirements, the operating coil current should lie between the limits of 0.31 amp. and 0.34 amp. when the reading indicated on voltmeter V1 is 80 volts.

Alternative procedure

10. If a variable speed drive, giving a generator speed range of 3,000 r.p.m. to 7,000 r.p.m., is available, then the diverter and series resistors are not necessary. The variation of pile resistance called for in the regulation test can then be obtained by running the generator on no load and varying its speed from 3,000 r.p.m. to 6,000 r.p.m. approximately.

Stability test

11. To check the stability of the regulator, the series resistor is to be short-circuited, and the diverter resistor open-circuited. The generator is then to be run on a load of 4 amp. and an additional load of 11 amp. switched on and off at least three times at generator speeds of 5,000 r.p.m. and 6,000 r.p.m. Under these conditions, the regulator must be critically damped.

12. Immediately following the above test, slacken the pile compression screw $\frac{3}{16}$ th turn, and repeat the test given in para. 11 without further adjustment to the load resistors R1 and R2. Under this condition, the regulator must respond and settle without sustained hunting.

Note . . .

The $\frac{3}{16}$ th turn quoted in para. 12 is a minimum.

13. Provided the regulator satisfied the test given in para. 12, the original setting of the compression screw is to be restored and the regulation test given in para. 7 to 9 repeated.

Checking a new regulator

14. The full tests are not necessary for a new regulator. It can be tested as follows, by connecting it in the test circuit as shown in fig. 2, but without the series and diverter resistors and without meters A2 and V2.

15. Run the generator at 4,000 r.p.m. and at 6,000 r.p.m., first on a 5 amp. load and then on a 15 amp. load. Throughout these tests the line volts V1 must not vary by more than 3 volts, and the regulator must remain stable when the 10 amp. load is switched on and off.

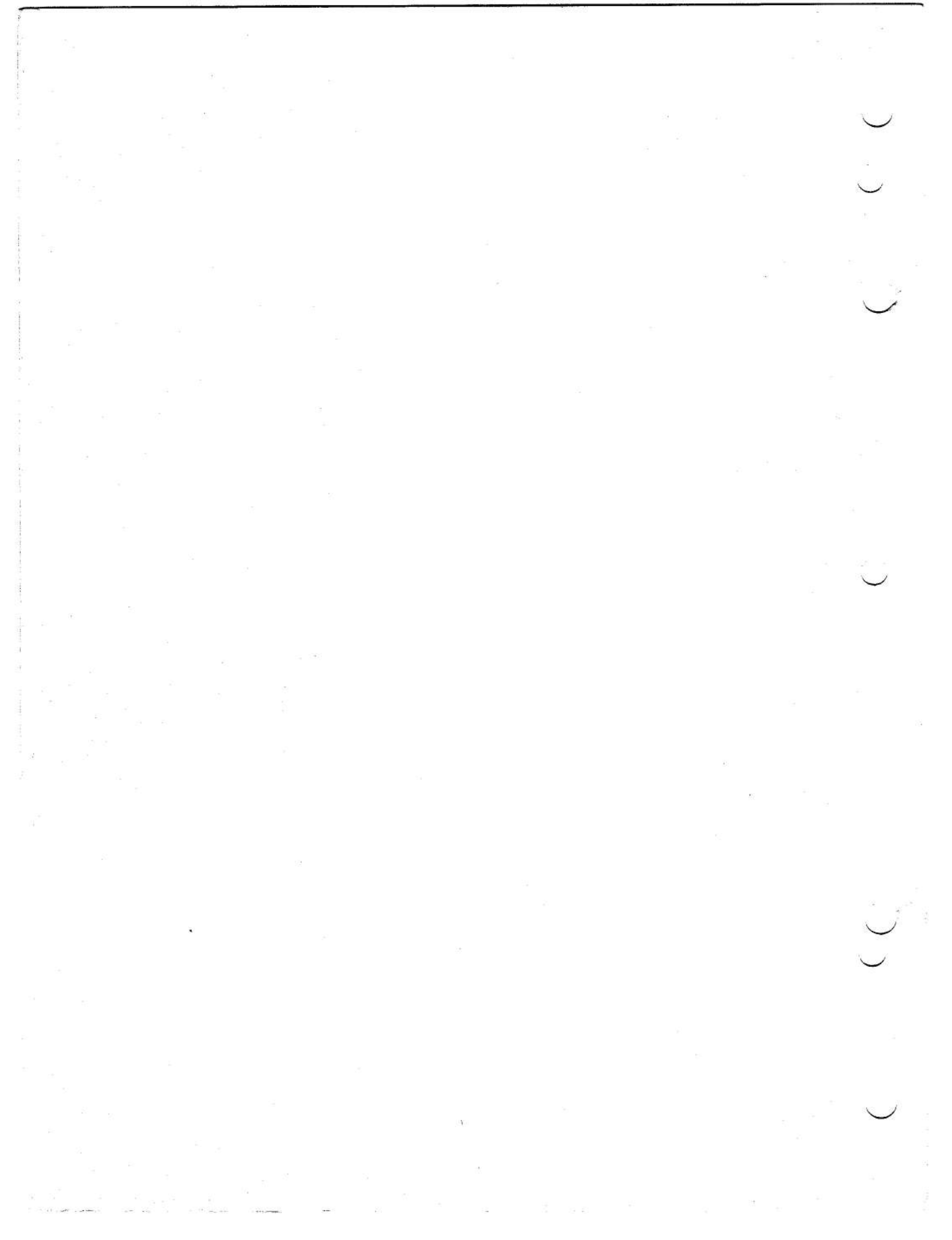

This file was downloaded
from the RTFM Library.

Link: www.scottbouch.com/rtfm

Please see site for usage terms,
and more aircraft documents.

