

Chapter 23

VOLTAGE REGULATOR, TYPE 50

LIST OF CONTENTS

	Para.		Para.
Introduction	1	Test installation	6
Description	2	Regulation test	7
Installation	4	Stability test	9
Servicing	5		

LIST OF ILLUSTRATIONS

	Fig.		Fig.
Voltage regulator, Type 50 (compression screw cover removed)	1	Circuit diagram	2
		Test circuit diagram	3

LEADING PARTICULARS

Voltage regulator, Type 50	Stores Ref. 5UC/5212
Control level	115 volts a.c. ± 2 per cent
Pile resistance range	1 to 15 ohms
Maximum pile loading	160 watts
Coil resistance	160 ohms (cold)
Coil current	0.21 to 0.23 amp.
Pre-set ballast resistors (2 \times 220 ohms)	Stores Ref. 5UC/5537
Trimmer resistor (50 ohms)	Stores Ref. 5UC/5096
Stabilizing transformer	Ratio 1000-600
Winding resistance	Secondary 45.5 ohms—Primary 11.5 ohms
Primary series resistor (30 ohms)	Stores Ref. 10W/Z243045

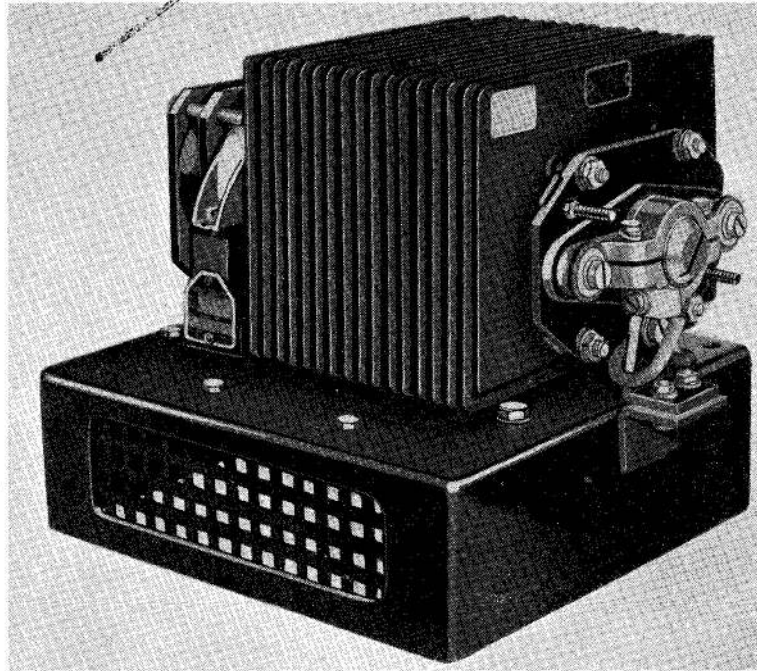

Fig. 1. Voltage regulator, Type 50 (compression screw cover removed)

Introduction

1. The voltage regulator, Type 50 (fig. 1) is normally used to maintain a steady output of 115 volts a.c. from the generator, Type Y1. General information on this type of regulator will be found in A.P.4343, Vol. 1, Sect. 6, Chap. 2.

DESCRIPTION

2. This regulator is fitted with a stabilizing transformer, which under conditions of rapid changes of load and speed provides a damping effect to the pile operating coil to prevent hunting. The primary winding of the transformer is connected across the exciting field of the generator. The secondary winding is connected in series with the carbon pile operating coil.

3. A composite carbon pile is fitted and consists of a minimum of 50 washers 0.5 mm. thick and 26 washers 3 mm. thick. The pile elements are capable of dissipating 160 watts continuously. A circuit diagram is given in fig. 2.

INSTALLATION

4. The regulator should be mounted in an upright position with the pile tube horizontal. The connections are indicated in the circuit diagram in fig. 2, but details of an individual installation should be verified from the electrical section of the appropriate Aircraft Handbook. Care must be taken to ensure that nothing is done to prevent free circulation of air around the regulator.

SERVICING

5. General servicing instructions for this type of regulator are given in A.P.4343, Vol. 1, Sect. 6, Chap. 1 and 2. Chap. 1 describes the

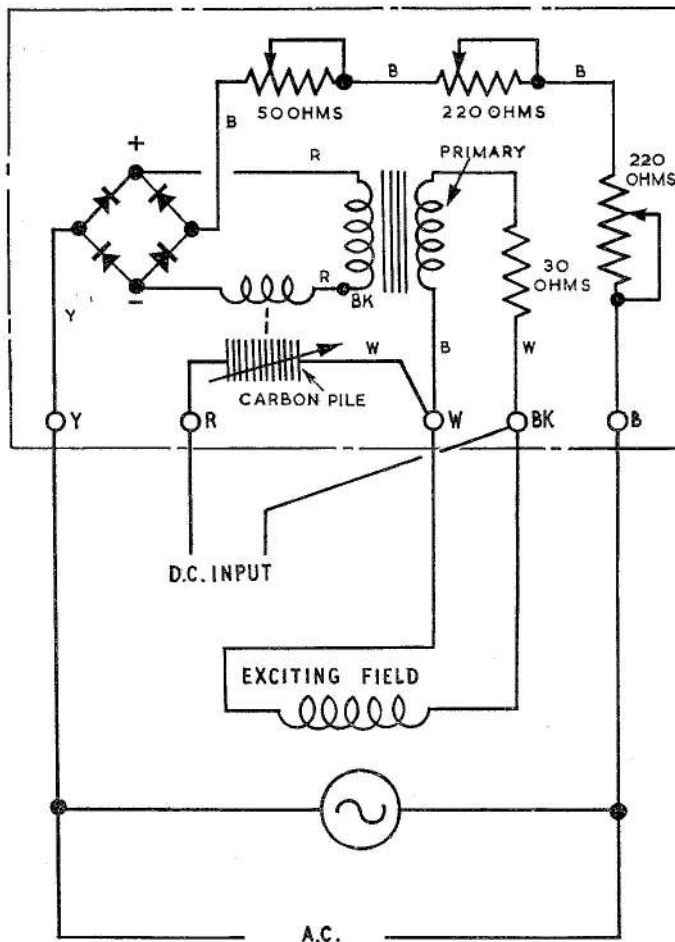

Fig. 2. Circuit diagram

RESTRICTED

VOLTAGE REGULATOR, TYPE 50

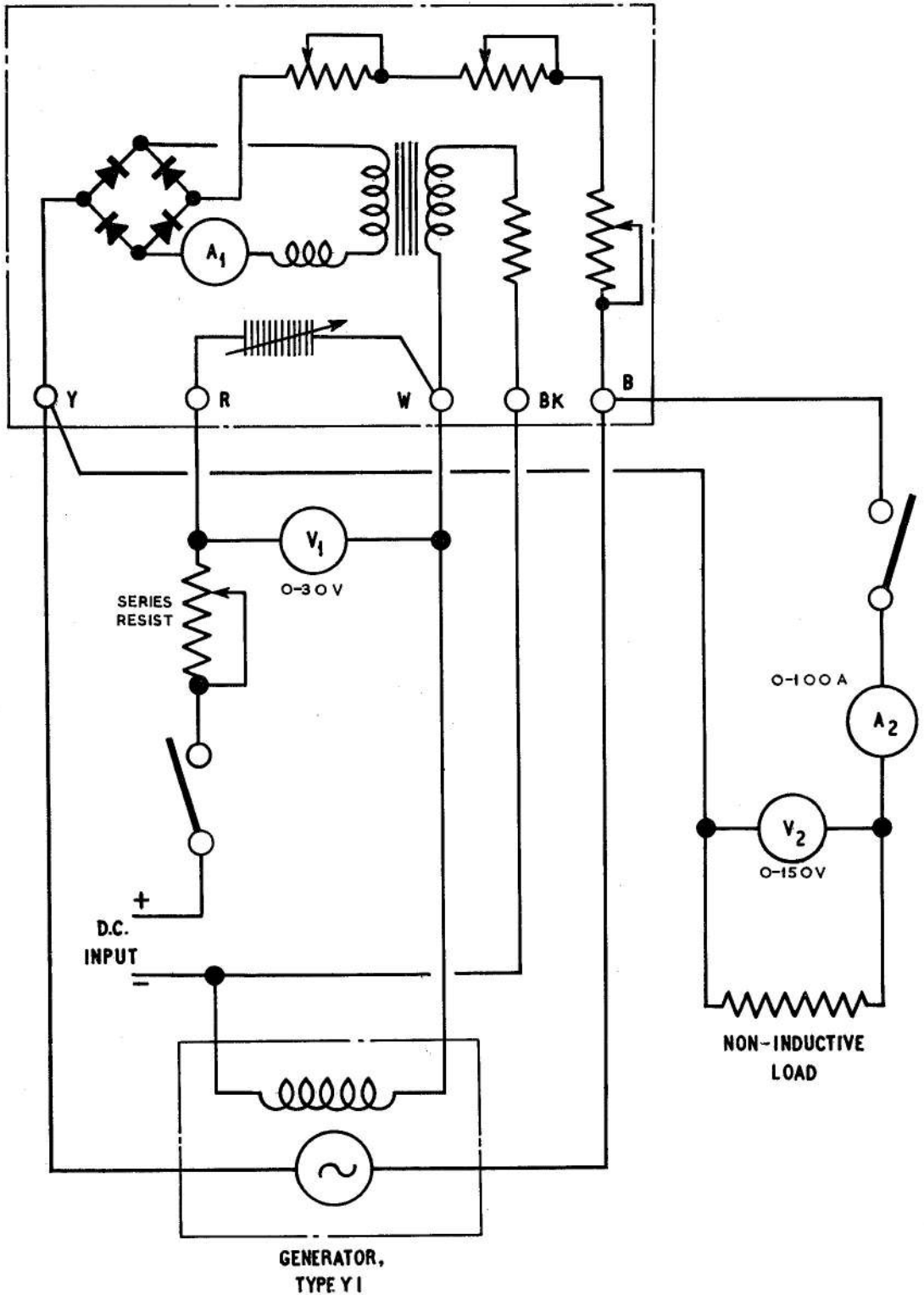

Fig. 3. Test circuit diagram

method of adjusting a regulator which is out of order; if any adjustment is made, the regulator must be fully tested as described in the following paragraphs.

Test installation

6. Connect the regulator in the test circuit as shown in fig. 3, the generator used being a Type Y.1, (Stores Ref. 5U/5211) excited from a 28-volt supply. For all tests the speed of the generator must be maintained at 4,000 r.p.m. unless otherwise stated.

Regulation test

7. Run the generator on no load and adjust the speed from 3,000 r.p.m. to 4,800 r.p.m., and then decrease to 3,000 r.p.m. During this cycle, check that the output voltage is maintained at 115 volts \pm 3 per cent measured on voltmeter V_2 . The coil current, measured on ammeter A_1 should be between 0.21 amp. to 0.23 amp.

8. The above test should be repeated with the generator on full load, and over the speed range of 3,000 r.p.m. to 4,800 r.p.m. the output voltage of 115 volts \pm 3 per cent must again be maintained.

Stability test

9. To check the regulator for stability, switch the generator field on and off at least three times, at a generator speed of 5,000 r.p.m. on no load and with the series resistance shorted out. Under these conditions the regulator must respond without any tendency to hunt.

10. Immediately following the above test, slacken the pile compression screw $\frac{1}{4}$ turn, lock in this position and repeat the test given in para. 9. Under this condition the regulator must respond and settle without sustained hunting.

11. Provided the regulator satisfies the test given in para. 10, restore the original setting of the pile compression screw and repeat the regulation test given in para. 7 and 8.

RESTRICTED

This file was downloaded
from the RTFM Library.
Link: www.scottbouch.com/rtfm

Please see site for usage terms,
and more aircraft documents.

