

**Chapter 41**

**VOLTAGE REGULATOR TYPE 114**

(Completely revised)

**LIST OF CONTENTS**

	Para.
Introduction ... ..	1
Description ... ..	2
Servicing ... ..	7

**LIST OF ILLUSTRATIONS**

	Fig.
Voltage regulator Type 114 ... ..	1
Circuit diagram ... ..	2

**LIST OF APPENDICES**

	App.
Standard serviceability test for voltage regulator Type 114 ... ..	A

**LEADING PARTICULARS**

Voltage regulator, Type 114 ... ..	Ref. No. 5UC/6360
Controlled voltage ... ..	28V ± 1V
Maximum pile loading ... ..	180W
Pile resistance range ... ..	1.5 to 30 ohms
Operating coil current ... ..	1.05 to 1.1A
Operating coil resistance ... ..	3.2 ohms
Equalising coil resistance ... ..	0.4 ohms
Adjustable ballast/resistor ... ..	12 ohms (Ref. No. 5UC/1028)
Voltage boost resistor ... ..	12 ohms (Ref. No. 5UC/1028)
Trimmer diverter resistor ... ..	10 ohms, 20W (Ref. No. 5UC/6196)
Remote trimmer ... ..	10 ohms, 7½W (Ref. No. 5UC/5780)
Stabilising transformer series resistor ... ..	15 ohms, 30W (Ref. No. 5UC/6199)
Stabilising transformer ... ..	Ref. No. 5UC/6197
Primary winding ... ..	2.04 ohms
Secondary winding ... ..	0.56 ohms
Current transformer ... ..	Ref. No. 5UC/6198
Primary winding ... ..	0.63 ohms
Secondary winding ... ..	0.84 ohms
Dimensions ... ..	9.41 × 6.06 × 5.5 in.
Weight ... ..	11 lb. (approx.)

**RESTRICTED**

Now AD 113D  
 0773-13A  
 Note

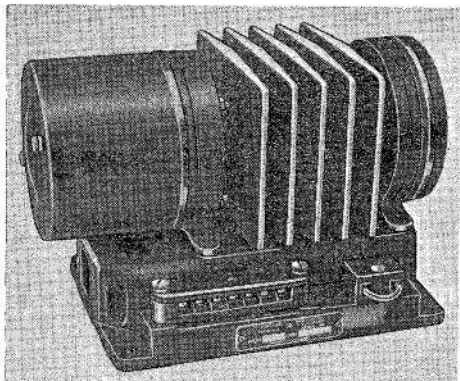

Fig. 1. Voltage regulator Type 114

### Introduction

1. The voltage regulator Type 114 is used to control the output of the 9kW generators, Type 512 series and Type 519 series at  $28V \pm 1V$ .

### DESCRIPTION

2. The regulator (fig. 1) is of the single carbon pile type, and in general construction and principle of operation is similar to the standard design as described in A.P.113D-0003-16 (formerly A.P.4343, Vol. 1, Sect. 6,

Chap. 1). It incorporates the flat type armature spring, with a bi-metallic strip embodied for temperature compensation. The pile is 4 in. in length and consists of not less than fifty 1 mm. washers interleaved with twenty-six 2 mm. washers.

3. The regulator unit is mounted on a base, beneath which are housed the associated resistors and stabilising transformers. The trimmer diverter resistor is connected through terminals 1 and 4 across the remote trimmer and associated wiring. This ensures that in the event of an open circuit of the remote trimmer or wiring, the voltage is maintained at a safe level.

4. Two adjustable ballast resistors are fitted, one with one adjuster, and the other with two. Part of the latter, which is connected between terminals 1 and 7, is used as a voltage boost resistor. This ensures that an adequate differential voltage is obtained to bring a second generator on to the bus-bar; when the generator has been brought on-line, that part of the resistor is automatically short circuited, and so rendered ineffective.

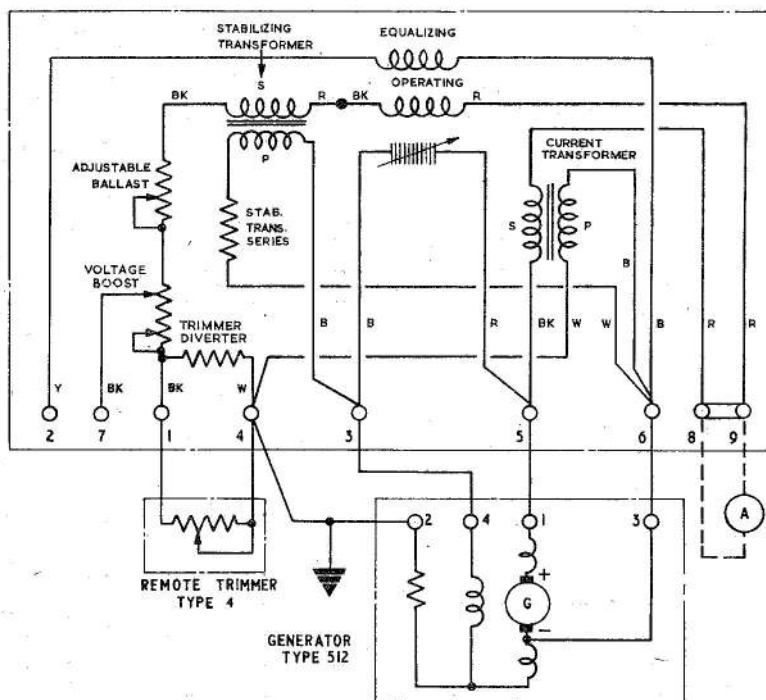

Fig. 2. Circuit diagram

**RESTRICTED**

5. An equalising coil is incorporated to ensure that the load is shared approximately equally between generators operating in parallel. The coil supply is derived from the voltage drop across the generator series field winding.

6. Two transformers, a stabilizing and a current transformer, are fitted to maintain the stability of the regulator during sudden changes of speed or load. The stabilizing transformer has its primary winding connected across the generator shunt field, and its secondary in series with the operating coil. Under stable conditions, no voltage is induced in the secondary winding, but when the generator speed increases, a voltage will be induced in the secondary winding such as to oppose the compensating effect of the operating coil, and so damp any tendency towards oscillation. A similar action results from the operation of the current transformer, due to variations in generator output.

### SERVICING

7. General servicing instructions for this type of regulator given in A.P.113D-0003—16 (formerly A.P.4343, Vol. 1, Sect. 6, Chap. 1) describe the fitting of a new pile stack, the preliminary mechanical adjustment and final setting up procedure for a regulator which is completely out of order. The latter part of this publication gives information on Repair and Reconditioning on this type of regulator. When any adjustment is made the regulator must afterwards be subjected to a full test.

#### Note . . .

(1) *The correct setting for the pile compression screw on this regulator, after the regulator has been correctly dipped is 0.005 in. in from the dip position.*

(2) *On this regulator the pile adjusting bracket is calibrated in thousandths of an inch, indicating the amount of rotation required to effect the stated amount of pile movement.*

0

00

0

0

000

**Appendix A**

**STANDARD SERVICEABILITY TEST**

**for**

**VOLTAGE REGULATOR, TYPE 114**

**LIST OF CONTENTS**

	<i>Para.</i>		<i>Para.</i>
<i>Introduction</i> ... ..	1	<i>Regulation test</i> ... ..	6
<i>Test equipment</i> ... ..	2	<i>Voltage boost test</i> ... ..	7
<b>Test procedure</b>		<i>Equalizing test</i> ... ..	8
		<i>Stability test</i> ... ..	9
<i>General</i> ... ..	3	<i>Insulation resistance test</i> ... ..	11

**ILLUSTRATION**

	<i>Fig.</i>
<i>Test circuit diagram</i> ... ..	1

**Introduction**

1. The following tests should be applied to the regulator whenever it is necessary to determine its serviceability.

**Test equipment**

2. The following items of test equipment will be required when testing the regulator:

- |  |  |
|--|--|
| <p>(1) Generator Type 512 series or Type 519 series.</p> <p>(2) Remote trimmer Type 4.</p> <p>(3) Ammeter 0-3A (A1), Ref. No. 5Q/3093.</p> <p>(4) Ammeter 0-20A (A2), Ref. No. 5Q/25093.</p> | <p>(5) Multimeter Type 12889 (V1), Ref. No. 5QP/17447.</p> <p>(6) Voltmeter 0-40V (V2), Ref. No. 5Q/234.</p> <p>(7) Variable resistor 0-10 ohms 5 amp (R1).</p> <p>(8) Switch S.P.6 amp (S1) Type N.S.F., Ref. No. 5CW/5813.</p> <p>(9) Switch S.P.3 amp (S3) Type N.S.F., Ref. No. 5CW/4787.</p> <p>(10) Insulation resistance tester Type C.</p> |
|--|--|

**RESTRICTED**

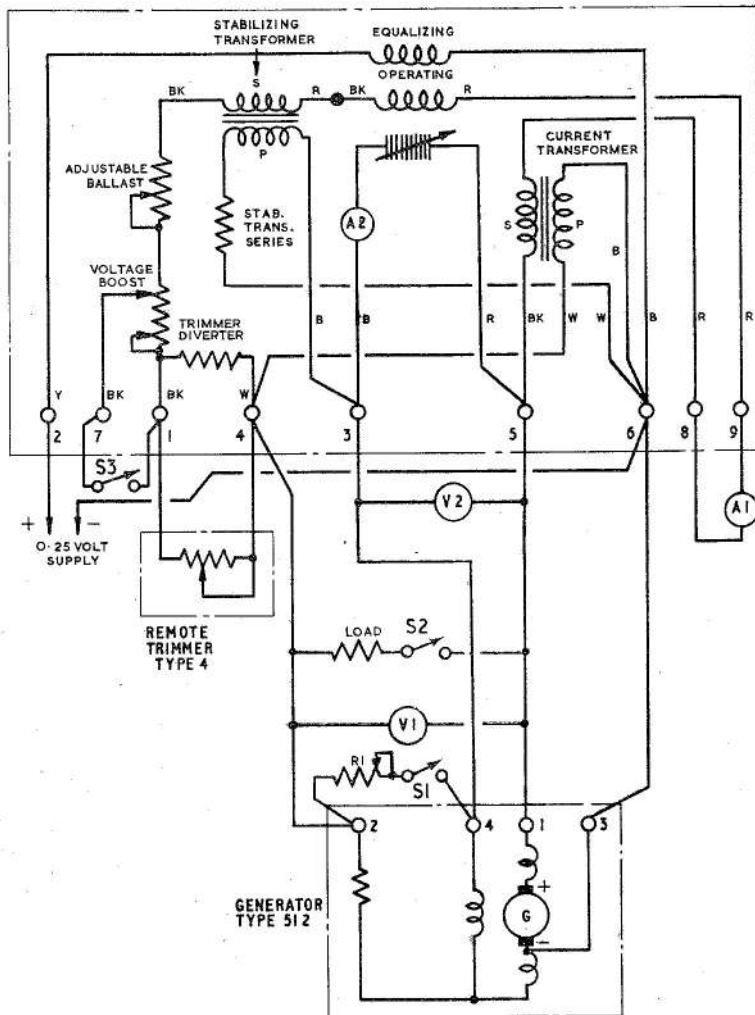

Fig. 1. Test circuit diagram

## TEST PROCEDURE

### General

3. Connect the regulator Type 114 to the test circuit as shown in fig. 1. This circuit shows the regulator connected to a generator of the Type 512 series, a generator of the Type 519 series would also be suitable; the use of either type ensures that the stability characteristics of the regulator are checked. Switch S1 and S2 should be open; switch S3 should be closed for all tests except the voltage boost test (para. 7).

4. With the regulator cold, run the generator at 5000 rev/min. Set the remote

trimmer in the electrical mid-position. The output voltage at V1 should be 28V and the main coil current A1 within the limits of 1.05A and 1.1A. If this voltage and current are not obtained refer to A.P.113D-0003-16, para. 40 to 45 (formerly A.P.4343, Vol. 1, Sect. 6, Chap. 1, para. 40 to 45).

### Note . . .

(1) The correct setting for the pile compression screw on this regulator, after the regulator has been correctly dipped is 0.005 in. in from the dip position.

(2) On this regulator the pile adjusting

**RESTRICTED**

*bracket is calibrated in thousandths of an inch, indicating the amount of rotation required to effect the stated amount of pile movement.*

#### Regulation test

6. (1) Run the generator smoothly over a speed range of 3000 to 10000 to 3000 rev/min. Repeat this cycle and check that the controlled voltage is maintained within the limits of 27V and 29V.
- (2) Run the generator at 3000 rev/min. Switch in field diverter resistance R1 at its max. value by closing switch S1, adjust R1 to obtain a minimum pile resistance of 2 ohms measured by ratio  $V2/A2$  (this simulates the condition of the machine on full load). The controlled voltage at V1 should be maintained within the limits of 27V and 29V. Increase R1 to maximum value, open switch S1.

#### Voltage boost test

7. Observe that the controlled voltage level is 28V. Open switch S3, the controlled voltage V1 should rise to between 29V and 29.5V.

#### Equalizing test

8. Connect a separate supply of 0.25V across the equalizing coil circuit, the positive lead being connected to terminal 2, negative to terminal 6. When the voltage is applied, the line voltage should be reduced from 28V to between 25.25V and 25.75V.

#### Stability test

9. Run the generator at 10000 rev/min, and switch a load of 150A on and off at least three times. Under these conditions the regulator should be critically damped.
10. Following the test in para. 9, turn the pile compression screw counter-clockwise 0.005 in., and repeat the stability test. At this setting of the pile compression screw the regulator should respond without tendency to sustained hunting. Provided the regulator satisfies this test, the pile compression screw should be returned to its original setting and the regulation test, para. 6, repeated.

#### Insulation resistance test

11. Using the insulation resistance tester Type C, measure the insulation between all connecting leads and frame, the reading should be not less than 5 megohms.

**RESTRICTED**

500

0

0

00

0

This file was downloaded  
from the RTFM Library.  
Link: [www.scottbouch.com/rtfm](http://www.scottbouch.com/rtfm)

Please see site for usage terms,  
and more aircraft documents.

