

Chapter 46

VOLTAGE REGULATOR, TYPE 121

LIST OF CONTENTS

	Para.		Para.
Introduction ... ..	1	Using a machine of similar	
Description ... ..	2	characteristics ... ..	15
Installation ... ..	6		
Servicing ... ..	7		
Testing			
General ... ..	8		
Regulation test ... ..	11		
Stability test... ..	12		
Using the correct machine ... ..	13		

LIST OF ILLUSTRATIONS

	Fig.
Voltage regulator Type 121 ... ..	1
Underside of regulator ... ..	2
Circuit diagram ... ..	3
Test circuit diagram ... ..	4

LEADING PARTICULARS

Voltage regulator Type 121	Ref.No.5UC/6886
Controlled voltage	28V ± 2½%
Maximum pile loading	100 W.
Pile resistance range	1.5 to 25 ohms
Operating coil current	1 to 1.1 amp.
Operating coil resistance	6.1 ohms (cold)
Ballast resistor (adjustable)	2 × 12 ohms
Ballast resistor (trimmer diverter)	7 ohms 20 W.
Remote trimmer	10 ohms 7½ W.
Stabilising transformer	
Ratio	1/2
Primary winding	0.42 ohm
Secondary winding	0.2 ohm
Series resistor	0.2 ohm 20 W.
Dimensions	7.75 × 6.44 × 6.13 in.

RESTRICTED

Now AP 113 D - 07106 - 1  
 Not used.

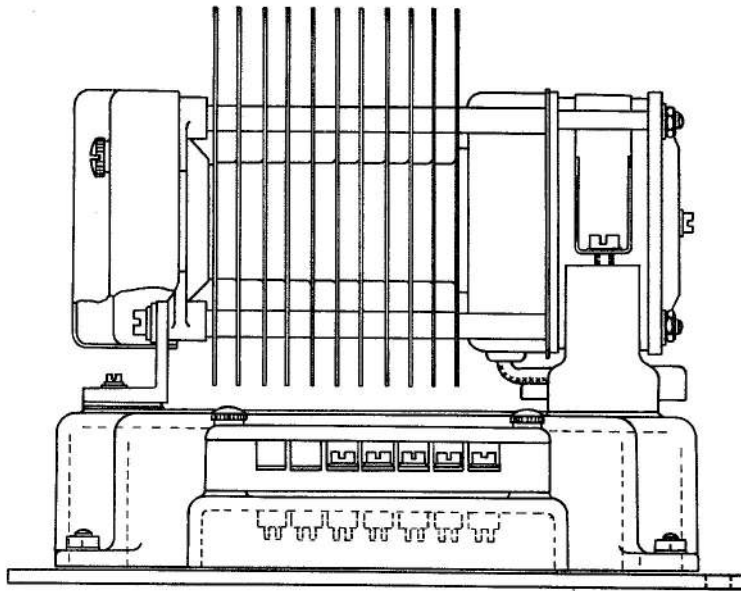

**Fig.1 Voltage regulator Type 121**

#### **Introduction**

1. The voltage regulator Type 121 is used to control the output of the generator Type 521 (E.E. Type AE 2511) at  $28V \pm 2\frac{1}{2}\%$ .

#### **DESCRIPTION**

2. The regulator (fig.1) is of the single carbon pile type, and in general construction and principle of operation is similar to the standard design as described in A.P.4343, Vol.1, Sect.6, Chap.1. The pile is 73mm. in length and is made up of sixty seven 1 mm. washers, with a 3 mm. washer at each end.

3. The carbon washers are located in a ceramic tube enclosed in a finned cooler which dissipates the heat from the carbon pile. This unit, with the armature assembly is mounted on a base under which are housed the adjustable ballast, trimmer diverter, and stabilising transformer series resistors, and the stabilising transformer.

4. The operating coil is connected in series with the two adjustable ballast resistances across the output of the generator. A remote trimmer is connected across terminals 1 and 4, that is, across the trimmer diverter resistance. This ensures that in event of an open circuit in the external wiring to the trimmer, the voltage level is still maintained within safe limits.

5. A stabilising transformer is fitted to maintain the stability of the generator during sudden changes of speed or load. It is connected as shown in fig.3 with the primary winding across the generator series field, and the secondary winding in series with the operating coil. Under stable conditions no voltage is induced in the secondary winding, but when the generator speed or load changes suddenly a voltage will be induced in the secondary winding so as to oppose the compensating effect of the operating coil, and so damp out any tendency towards oscillation.

**RESTRICTED**

**INSTALLATION**

6. The regulator should be mounted with the axis of the carbon pile horizontal and the regulator base in a vertical plane. It should be in such a position that there is no restriction to free circulating air through the cooling fins.

**SERVICING**

7. General servicing instructions for this type of regulator are given in A.P.4343, Vol.1, Sect.6, Chap.1, where information will be found on changing the carbon pile, and on setting up a regulator which is completely out of adjustment. When any adjustment is made the regulator must afterwards be subjected to a full test.

**TESTING****General**

8. The test circuit given in fig.4 shows a diverter resistor across the carbon pile and a resistor in series with the generator field. The need for series and diverter resistors will be determined by whether the pile resistance range can be covered by generator speed control, and by the characteristics of the particular generator used for test.

9. Connect the regulator to the test circuit as shown in fig.4. It is desirable that tests should be performed with the generator for which the regulator was designed, if this type is not available a generator of

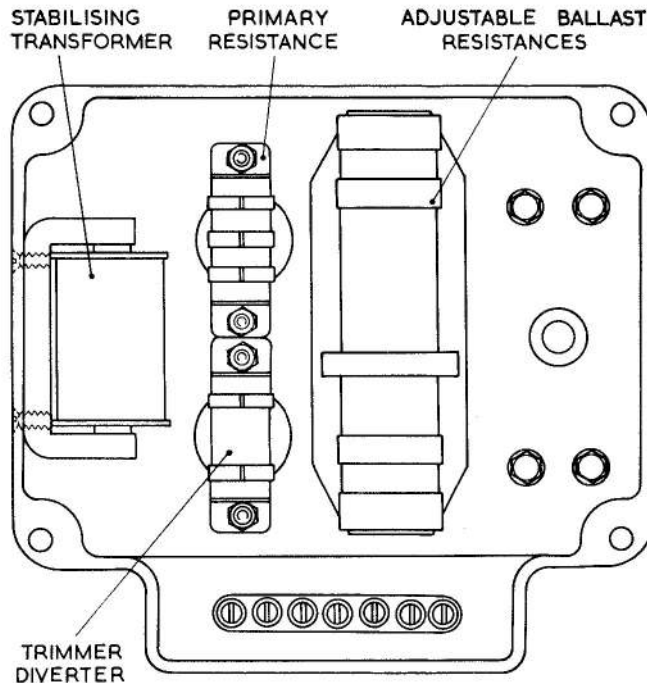

Fig.2 Underside of regulator

RESTRICTED

suitable characteristics should be used. If the tests are carried out with other than a generator of the correct type the stabilising transformer primary winding should be disconnected for all tests.

10. Run the generator at normal speed with the regulator adjusted to control at 28V., the coil current A.1 should be within the limits of 1 to 1.1 A. with the trimmer in approximately the mid position.

#### Regulation test

11. Run the generator over a speed range so that the pile resistance as measured by  $V_2/A_2$  varies between 1.5 to 25 ohms. Over this resistance range the voltage  $V_1$  should

be maintained within the limits of  $28V \pm 2\frac{1}{2}\%$ .

#### Stability test

12. The procedure for stability testing depends on whether the correct generator, or a generator of similar characteristics is used. Both methods are given in the following paragraphs.

#### Using the correct machine.

13. Run the generator at maximum speed, switch the full generator load on and off at least three times. Under these conditions the regulator should be critically damped.

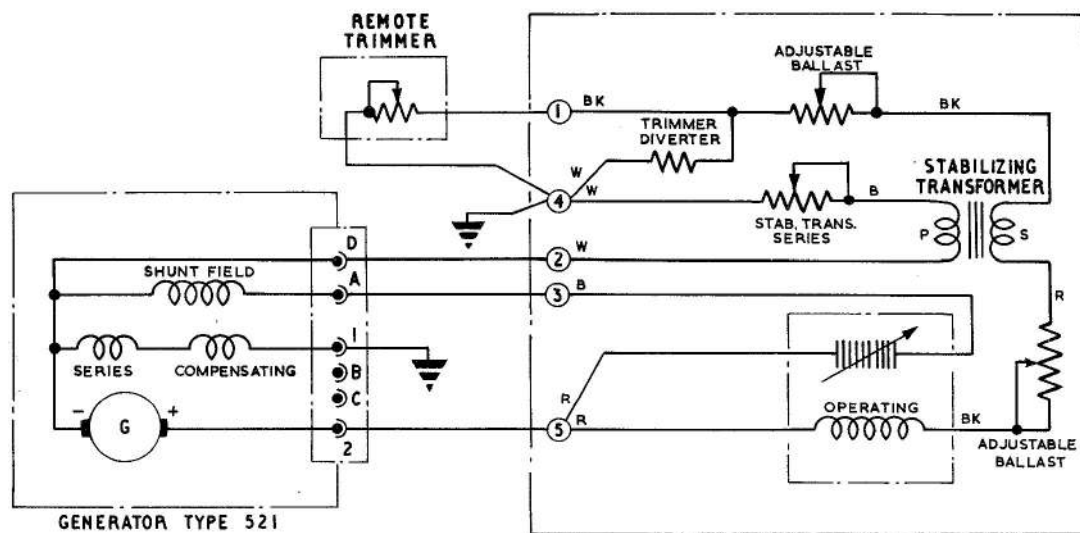

Fig.3 Circuit diagram

RESTRICTED

14. Following the test in para.13, turn the pile compression screw counter-clockwise  $\frac{1}{4}$  turn and repeat the stability tests. At this setting of the pile compression screw the regulator must respond without tendency to sustained hunting. Provided the regulator satisfies this test the pile compression screw should be restored to its original setting and the regulation test repeated.

*Using a machine of similar characteristics*

15. When the test is performed with other than a generator of the correct type, the stabilising transformer primary winding should be disconnected. Run the generator at a speed to give the maximum pile resistance of 25 ohms as measured by  $V_2/A_2$ , open the generator field switch and adjust

the series resistors so that the pile resistance is at the minimum 1.5 ohms, close the field switch. The generator field switch should then be switched on and off at least three times. Under these conditions the regulator should be critically damped.

16. Following the tests in para.15 turn the pile compression screw counter-clockwise  $\frac{1}{8}$  turn and repeat the stability test. At this setting of the pile compression screw the regulator must respond without tendency to sustained hunting. Provided the regulator satisfied this test, restore the pile compression screw to its original setting and repeat the regulation test. The controlled voltage must be maintained at  $28V. \pm 2\frac{1}{2}\%$  over the pile resistance range of 1.5 to 25 ohms.

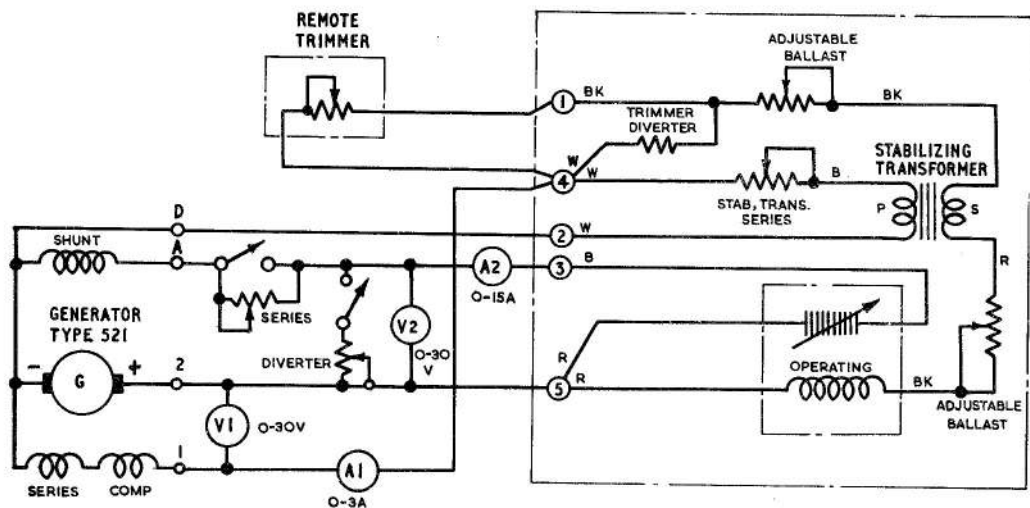
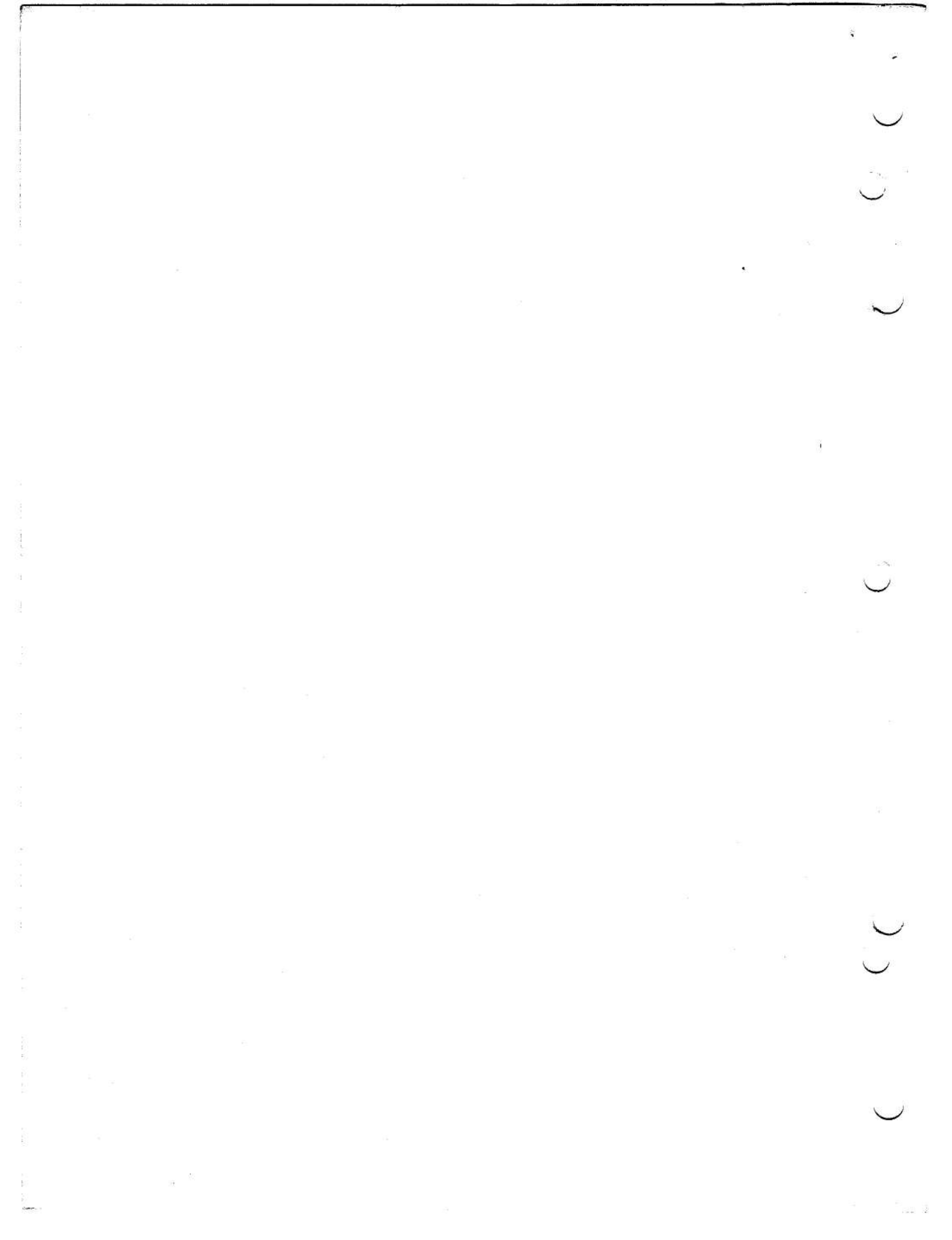

Fig.4 Test circuit diagram

RESTRICTED



This file was downloaded  
from the RTFM Library.

Link: [www.scottbouch.com/rtfm](http://www.scottbouch.com/rtfm)

Please see site for usage terms,  
and more aircraft documents.

