

Chapter 48

VOLTAGE REGULATOR TYPE B/52760E

LIST OF CONTENTS

	Para.		Para.
Introduction	1	Testing of cut-out	16
Description	2	Closing test	17
Installation	6	Opening test	19
Servicing	7		
Testing of regulator	8	LIST OF ILLUSTRATIONS	
Regulation test... ..	9		
Stability test	10		Fig.
Adjustment of cut-out		Voltage regulator Type	
Closed air gap	12	B/52760E	1
Open air gap	13	Underside of regulator... ..	2
Contacts	14	Circuit diagram	3
		Test circuit diagram	4

LEADING PARTICULARS

Voltage regulator Type B/52760E	Ref.No.5UC/
Controlled voltage	28V. ± 0.5V.
Carbon pile	Ref.No.5UC/
Cut-out Type G.2...	Ref.No.5CY/3934
Pile resistance range	1-12 ohms
Maximum pile loading	50W.
Operating coil current	0.85 - 0.93A
Operating coil resistance	11 ohms (cold)
Semi-adjustable ballast resistor	26 ohms
Trimmer diverter	10 ohms 12W
Remote trimmer	10 ohms 7½W
Stabilising series resistor	400 ohms 12W

RESTRICTED

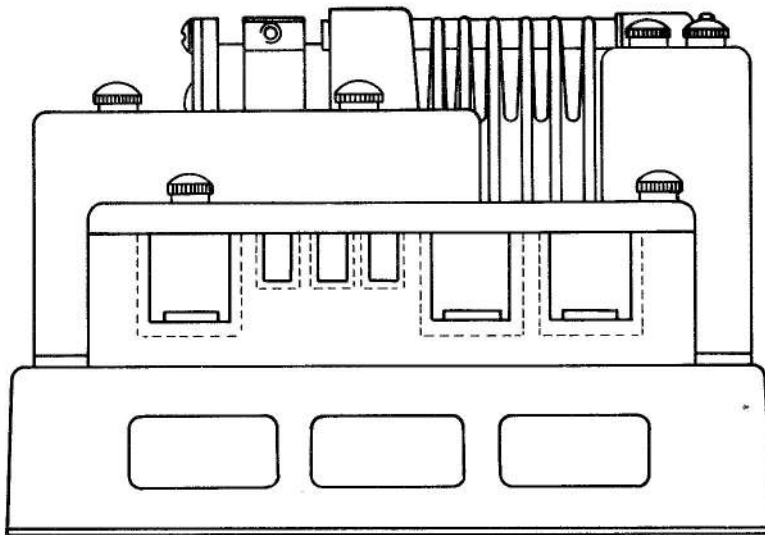

Fig.1 Voltage regulator Type B/52760E

Introduction

1. The voltage regulator Type B/52760E is used to control the output of the Generator, Rotax, Type B.2901 at $28V \pm 0.5V$.

DESCRIPTION

2. The regulator (fig.1) is of the single carbon pile type, and in general construction and principle of operation is similar to the standard design as described in A.P.4343, Vol.1, Sect.6, Chap.1. It is mechanically similar to the regulator and cut-out unit, Type B (Ref. No. 5UC/3880).

3. The regulator unit incorporates a carbon pile made up of thirteen 3 m.m. washers, interleaved with twenty four 0.5 m.m. washers, assembled two and one. This unit, with the reverse current cut-out is mounted on a base beneath which are housed the ballast resistors for both the regulator and the cut-out, the trimmer diverter and stabilising series resistor.

4. The remote trimmer is connected between terminals 4 and 6, that is, across the trimmer diverter resistor. The trimmer diverter ensures that in the event of an open circuit in the external wiring to the remote trimmer, the voltage level is still maintained within safe limits.

5. Voltage stabilising is assisted by the provision of additional windings embodied with the voltage coil. Under normal conditions the shunt and series stabilising ampere turns counter balance, but under conditions of transients the ampere turns in the stabilising winding tends to reduce the total magnetic force, thus providing a stabilising influence on the performance of the regulator.

INSTALLATION

6. The regulator should be mounted with the axis of the carbon pile horizontal, and the regulator base in a vertical plane. It should be in such a position that there is

RESTRICTED

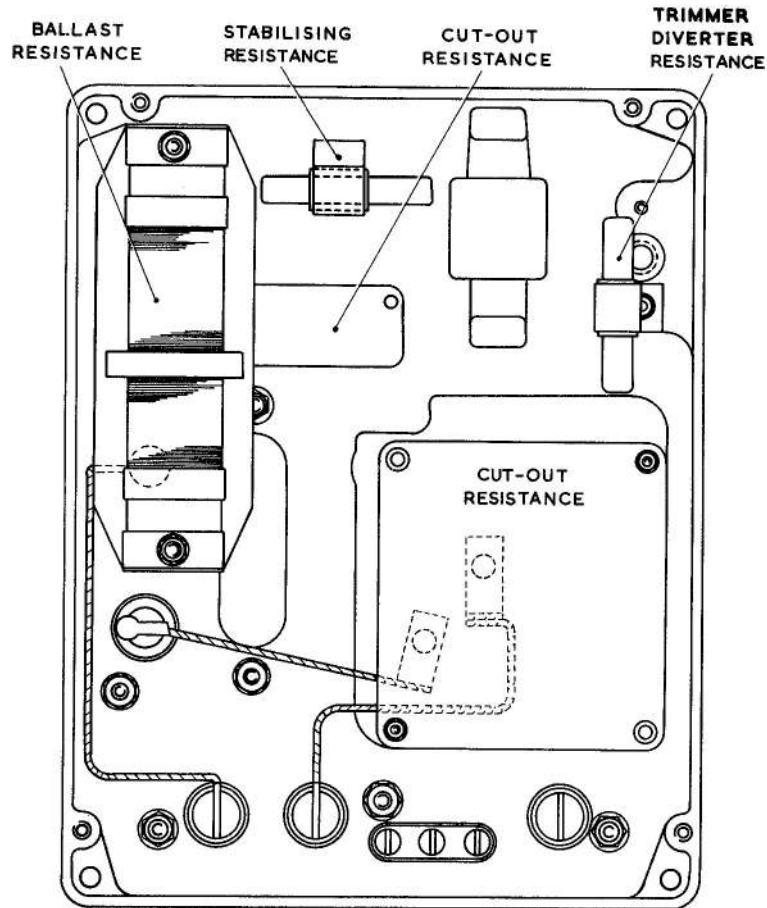

Fig.2 Underside of regulator

no restriction to free circulating air through the cooling fins.

SERVICING

7. General servicing instructions for this type of regulator are given in A.P.4343, Vol.1, Sect.6, Chap.1 and 3, where information will be found on changing the carbon pile, and on setting up a regulator which is completely out of adjustment. When any adjustment is made the regulator must afterwards be subjected to a full test.

Testing of a regulator

8. Connect the regulator to the test circuit as shown in fig.4. This shows the regulator connected to a generator Rotax Type B.2901, which should be driven by a variable speed generator test set. For all regulator tests, switches SW1 and SW3 should be closed, SW2 open, and the shunt field series resistor short circuited. The regulator should be adjusted to control at 28V, with the coil current within the limits of 0.85 - 0.93A.

RESTRICTED

Regulation test

9. With switch SW4 open, run the generator over a speed range so that the pile resistance as measured by V2/A1 varies between 1 and 12 ohms. Repeat the cycle and observe that the controlled voltage V2 is maintained within the limits of 28V. \pm 0.5V.

Stability test

10. Run the generator at a speed to give maximum pile resistance of 12 ohms as measured by V2/A1, operate SW4 to switch the full generator load on and off at least three times. Under these conditions, the regulator should be critically damped.

11. Following the test in para.10, turn the pile compression screw counter-clockwise by $\frac{1}{4}$ turn, and repeat the stability test. At this setting of the pile compression screw, the regulator must respond without any tendency to sustained hunting. Provided the regulator satisfies this test, the pile compression screw should be restored to its original setting, and the regulation test repeated. The controlled voltage should be maintained at 28V. \pm 0.5V, over a pile resistance range of 1 - 12 ohms.

Adjustment of cut-out

Closed air gap

12. With the cut-out armature fully closed by hand, the air gap between the armature and pole face, should be set by means of the adjusting screw in the middle of the adjustment bar, so that it is nowhere less than 0.025 $\begin{matrix} +0.002 \\ -0.000 \end{matrix}$ in., and then locked in that position.

Open air gap

13. With the armature in the open position, the air gap between the armature and the pole face should be set by means of the

screw stop in the end of the contact carrier plate. It should be so adjusted that it is nowhere less than 0.065 $\begin{matrix} +0.002 \\ -0.000 \end{matrix}$ in., and then locked in that position.

Contacts

14. No adjustment is required for the main contact clearance, which should follow automatically from the adjustment given in paras.12 and 13. It should be not less than 0.025 in. in the fully open position, between each fixed contact and the moving contact bar, measured simultaneously. All contact surfaces should be clean and smooth and the fixed contacts should be correctly lined up so that the moving contact bar makes contact approximately on their centre line.

15. When the air gap adjustments are correct, both adjustment lock-nuts should be sealed, after locking, by the application of a spot of air-drying varnish between the lock-nut and the frame.

Testing of cut-out

16. For test purposes the unit should be connected as shown in fig.4. During these tests it should be mounted so that the base is vertical and the cut-out coil axis horizontal, with the contacts at the bottom.

Closing test

17. With switches SW1 and SW3 closed, SW2 and SW4 open, the generator should be driven at its minimum speed, and the voltage increased slowly by means of the field series resistor. The closing voltage should be set by the adjusting nut on the control spring to between 26V and 27V, on a gradually increasing voltage; the contacts must close smartly within these limits.

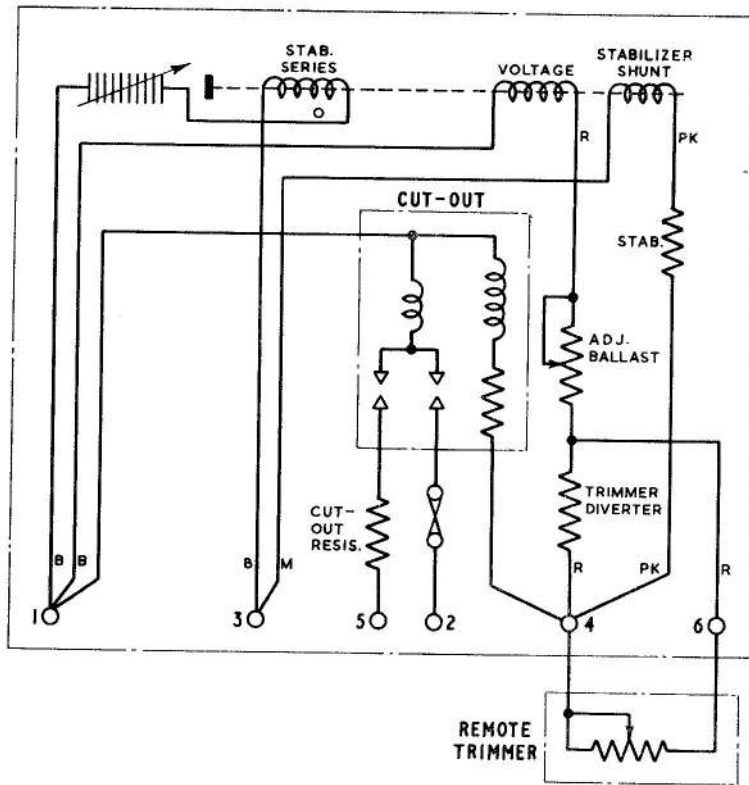

Fig.3 Circuit diagram

Note . . .

On any individual check setting the cut-out voltage must be reduced to zero, in order to eliminate hysteresis errors, to achieve this the main switch SW1 should be opened after the generator voltage has been reduced to the minimum by means of the field resistor.

18. After locking the adjusting nut, check that the closing voltage is still within the specified limits, if it is correct, seal the adjusting nut and lock-nuts with a spot of air-drying varnish.

Opening test

19. With the switches set as in para.17, the cut-out must open smartly when the generator voltage is reduced gradually from the pull-in value.

20. With switches SW1, SW2 and SW3 closed, the generator should be driven at its minimum speed, and the voltage increased by means of the field series resistor until the cut-out closes, and the battery charging current is approximately 10A. The generator excitation should be decreased slowly until the cut-out opens, and then SW1 should be opened.

RESTRICTED

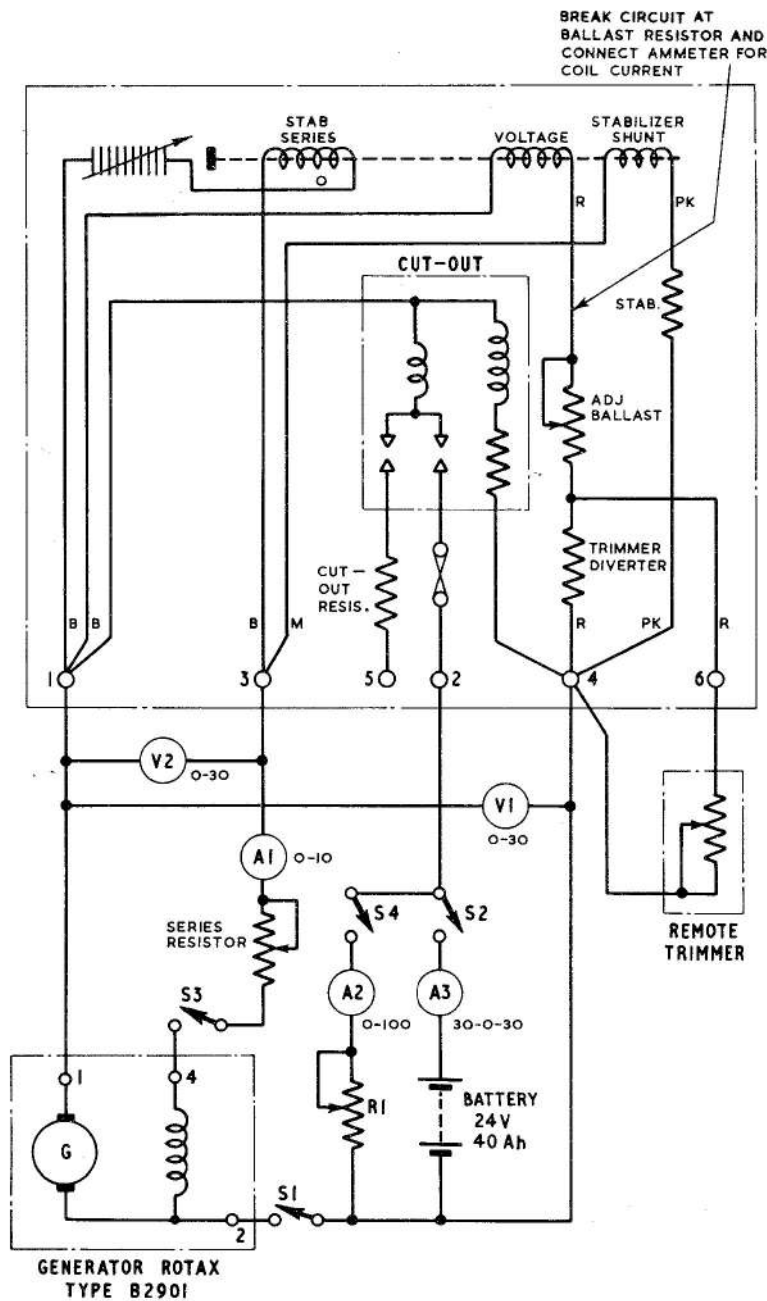

Fig.4 Test circuit diagram

21. Repeat this cycle of operations six times, and on each test, the cut-out should open without undue chattering at a discharge current of between 12A and 25A with a battery voltage of 23V to 24V. The cut-out should also close smartly between the specified voltage limits.

22. With the switches set as in para.20 and the battery charging current adjusted to approximately 10A, open SW3, and observe that the cut-out shows no tendency to remain closed on reverse current. This test should be made once only.

RESTRICTED

This file was downloaded
from the RTFM Library.

Link: www.scottbouch.com/rtfm

Please see site for usage terms,
and more aircraft documents.

