

Cancelled AL NO 5

REGULATOR AND CUT-OUT UNIT TYPE LKA 75 FORM B1

LIST OF CONTENTS

	<i>Para.</i>		<i>Para.</i>
<i>Introduction</i>	1	<i>Adjustment of cut-out</i>	
Description		<i>Main contacts</i>	20
<i>Regulator unit</i>	3	<i>Auxiliary contacts</i>	21
<i>Cut-out</i>	7	Testing	
<i>Voltage sensing relay</i>	9	<i>General</i>	22
<i>Equalizing isolating relay</i>	10	<i>Regulation test</i>	25
Operation		<i>Stability test... ..</i>	26
<i>Generator run up</i>	11	<i>Cut-out</i>	
<i>Generator run down</i>	15	<i>Closing test</i>	28
<i>Switching off... ..</i>	16	<i>Opening test</i>	29
Installation	17	<i>Testing complete unit... ..</i>	30
Servicing		<i>Insulation test</i>	31
<i>General</i>	18		

LIST OF ILLUSTRATIONS

	<i>Fig.</i>		<i>Fig.</i>
<i>Voltage regulator and cut-out</i>		<i>Sectional view of cut-out</i>	3
<i>Type LKA 75, Form B1</i>	1	<i>Circuit diagram</i>	4
<i>View of underside</i>	2		

LEADING PARTICULARS

Voltage regulator and cut-out unit										
Type LKA 75 Form B1	Ref.No. 5UC/6931
Controlled voltage	28V ± 0.75V
Carbon pile resistance range	2 to 38 ohms
Maximum pile loading	55W
Operating coil current	1.0A to 1.1A
Operating coil resistance	6.9 ohms
Ballast resistors (adjustable)	12 ohms

to the generator positive line, and to complete the circuit to connect the cut-out series coil across the shunt resistor.

- (2) The normally closed contacts open, to insert the voltage raising section of the regulator ballast resistor, and to interrupt the circuit through the 'throw off' resistor.

Equalizer isolating relay

10. The equalizer isolating relay is of the same series as the voltage sensing relay. It uses three pairs of normally open contacts, two of which are connected in parallel. When the cut-out auxiliary contacts close, a supply is fed to the operating coil of this relay, and the normally

open contacts close to complete the equalizing circuit and to short circuit the voltage raising resistor in the regulator.

OPERATION

Generator run up

11. Before commencing the generator run up it is essential that the bus-bar is at a potential of 24V to 28V. If the battery is not connected, the generator will cut-in at a low speed and a blown internal fuse may result.

12. When the generator terminal voltage has built up, in the correct polarity, to 16V to 20V, the voltage sensing relay closes. This completes the cut-out differential voltage coil circuit, and inserts the voltage

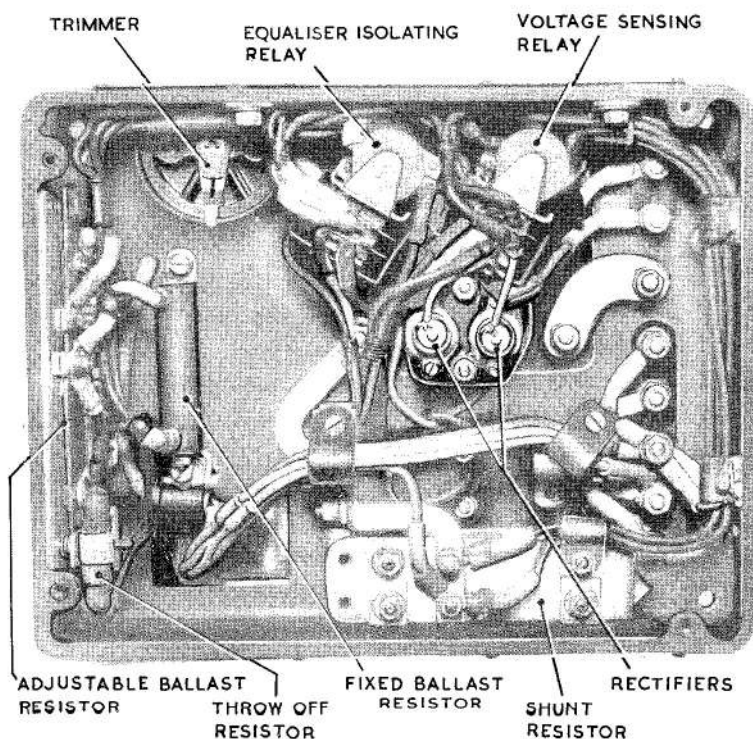

Fig.2. View of underside

RESTRICTED

Chapter 49
 Cancelled A.L. NO 3

REGULATOR AND CUT-OUT UNIT TYPE LKA 75 FORM B1

LIST OF CONTENTS

	Para.		Para.
<i>Introduction</i>	1	<i>Adjustment of cut-out</i>	
Description		<i>Main contacts</i>	20
<i>Regulator unit</i>	3	<i>Auxiliary contacts</i>	21
<i>Cut-out</i>	7	Testing	
<i>Voltage sensing relay</i>	9	<i>General</i>	22
<i>Equalizing isolating relay</i>	10	<i>Regulation test</i>	25
Operation		<i>Stability test</i>	26
<i>Generator run up</i>	11	<i>Cut-out</i>	
<i>Generator run down</i>	15	<i>Closing test</i>	28
<i>Switching off</i>	16	<i>Opening test</i>	29
Installation	17	<i>Testing complete unit</i>	30
Servicing		<i>Insulation test</i>	31
<i>General</i>	18		

LIST OF ILLUSTRATIONS

	Fig.		Fig.
<i>Voltage regulator and cut-out</i>		<i>Sectional view of cut-out</i>	3
<i>Type LKA 75, Form B1</i>	1	<i>Circuit diagram</i>	4
<i>View of underside</i>	2		

LEADING PARTICULARS

<i>Voltage regulator and cut-out unit</i>	
Type LKA 75 Form B1	Ref.No. 5UC/6931
Controlled voltage	28V ± 0.75V
Carbon pile resistance range	2 to 38 ohms
Maximum pile loading	55W
Operating coil current... ..	1.0A to 1.1A
Operating coil resistance	6.9 ohms
Ballast resistors (adjustable)	12 ohms

RESTRICTED

Ballast resistor (fixed)	12 ohms \pm 5%
Throw-off resistor	150 ohms
Voltage trimmer resistor	5 ohms 7.5 W
Stabilizing shunt coil resistance	550 ohms
Stabilizing series coil resistance	0.03 ohms
Equalizing coil resistance	1.38 ohms
Cut-out coil resistance												
Differential voltage	0.38 ohms \pm 15%
Shunt	365 ohms \pm 15%
Series	0.58 ohms \pm 15%

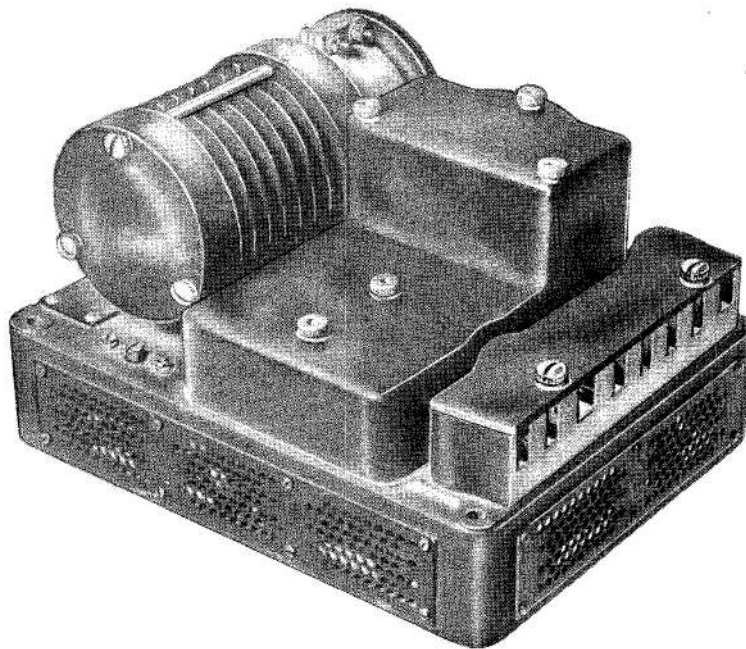

Fig. 1. Voltage regulator and cut-out Type LKA 75, Form B1

Introduction

1. The voltage regulator and cut-out unit Type LKA 75-B1 is used to control the output of the d.c. generator Type LG.2214 when operating with a single generator, or with up to four generators in parallel. The controlled output of this generator is 28V \pm 0.75V at 75A.

2. The unit is of two forms, the Type LKA 75 - B1 and the LKA 75 - B2. These

are interchangeable, they differ in that the cut-out contact mounting is a rigid pivot in the form B2, as opposed to a spring pivot in the form B1.

DESCRIPTION

Regulator unit

3. The regulator unit is of the single carbon pile type, and in general construction and principle of operation is similar

to the standard design as described in A.P.4343, Vol.1, Sect.6, Chap.1. It incorporates a carbon pile 52 mm. in length, made up of not less than fifty-two 1 mm. carbon washers.

4. The carbon washers are located in a ceramic tube, enclosed in a finned cooler which dissipates the heat from the carbon pile. This unit, with the armature assembly, is mounted on a base, under which are housed the adjustable ballast, fixed ballast, and trimmer resistors.

5. The operating coil is connected in series with the ballast and trimmer resistors across the generator output. Additional windings are embodied with the operating coil to provide a stabilizing influence under transient conditions due to sudden changes of speed or load. Under normal conditions, the shunt and series coil stabilizing ampere turns counter balance, but under conditions of transients the ampere turns in the shunt coil tend to reduce the total magnetic flux, thus providing a stabilizing influence on the performance of the regulator.

6. An equalizing coil is incorporated to ensure that the load is shared approximately equally between generators operating in parallel. The coil is such that with 1V applied across it in the correct direction, the controlled voltage level will be reduced from 28V to 18.75V approx.

Cut-out

7. The cut-out is polarized, and operates when a voltage differential exists between the generator and the bus-bar. Three coils are fitted, they are the differential voltage, the shunt and the series coils. The differential voltage coil is connected between

the generator positive line and the bus-bar, and its function is to connect the generator to the bus-bar when the generator line voltage rises above the bus-bar voltage. The shunt coil is connected across the generator output, and functions as a hold-in coil to keep the contacts closed when the generator is 'on line'. The series coil is connected in parallel with the heavy duty shunt resistor, and is supplied by the p.d. developed across the shunt when current flows in either direction through it. This provides positive ampere turns to assist the shunt coil when the generator is on load, and negative ampere turns to open the cut-out when the generator draws current from the bus-bar.

8. The unit incorporates main contacts and two auxiliary contacts which open and close in unison. The armature carrying the main contact at one end, and the auxiliary contacts buffer at the other, is pivoted at the centre of the solenoid core. The main contacts and the auxiliary contacts are adjustable. The complete assembly is mounted on an insulated base, and can be removed as a unit from the main component.

Voltage sensing relay

9. The voltage sensing relay is similar in construction and principle of operation to that described in A.P.4343C, Vol.1, Book 2, Sect.3, Chap.44, to which reference should be made. It comprises four pairs of contacts, two normally open and two normally closed. The relay is energized when the generator output rises to 16V to 20V, and its function is as follows:-

- (1) The normally open contacts close, to complete the circuit through the cut-out shunt and differential voltage coils

to the generator positive line, and to complete the circuit to connect the cut-out series coil across the shunt resistor.

- (2) The normally closed contacts open, to insert the voltage raising section of the regulator ballast resistor, and to interrupt the circuit through the 'throw off' resistor.

Equalizer isolating relay

10. The equalizer isolating relay is of the same series as the voltage sensing relay. It uses three pairs of normally open contacts, two of which are connected in parallel. When the cut-out auxiliary contacts close, a supply is fed to the operating coil of this relay, and the normally

open contacts close to complete the equalizing circuit and to short circuit the voltage raising resistor in the regulator.

OPERATION

Generator run up

11. Before commencing the generator run up it is essential that the bus-bar is at a potential of 24V to 28V. If the battery is not connected, the generator will cut-in at a low speed and a blown internal fuse may result.

12. When the generator terminal voltage has built up, in the correct polarity, to 16V to 20V, the voltage sensing relay closes. This completes the cut-out differential voltage coil circuit, and inserts the voltage

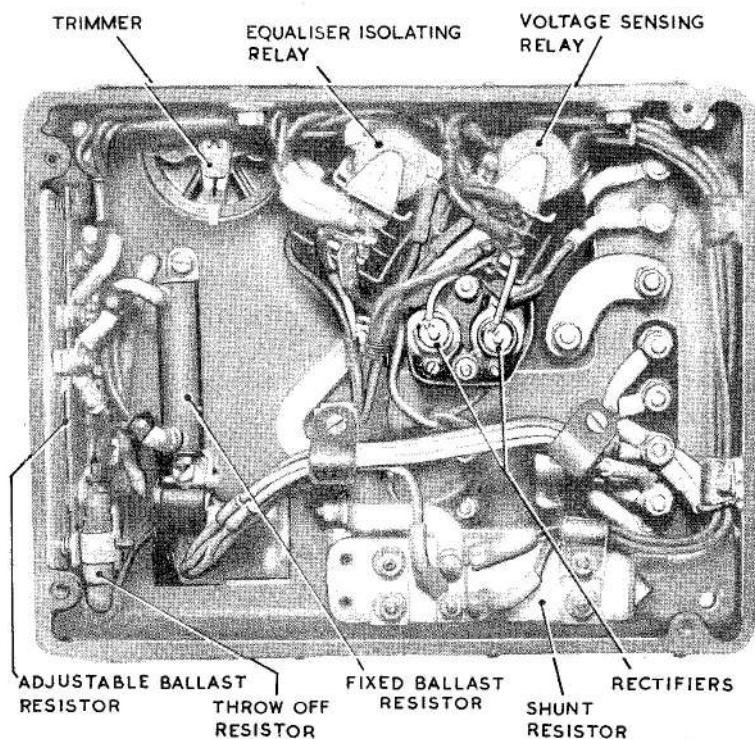

Fig.2. View of underside

RESTRICTED

raising section of the regulator ballast resistor.

13. When the generator terminal voltage exceeds the bus-bar voltage, current will flow through the cut-out differential voltage coil in the correct direction, and the cut-out will close. The cut-out normally closed auxiliary contacts will open to extinguish the power failure warning lamp, and the normally open contacts will close to supply the equalizer isolating relay coil.

14. The main contacts when closed, connect the generator to the bus-bar, and short circuit the differential voltage coil. The shunt coil holds the cut-out closed on no load. When the generator is on load the series coil assists the shunt coil, by providing positive ampere turns which give increased contact pressure with an increase in load.

Generator run down

15. When the generator terminal voltage falls below that of the bus-bar, a reverse current will be drawn from the bus-bar. This reverse current flows through the shunt resistor and is sensed by the series coil. A current will flow through this coil in a reverse direction, providing negative ampere turns to open the cut-out.

Switching off

16. When the generator is switched off, the voltage sensing relay is de-energized, and its normally closed contacts make to complete the circuit through the 'throw off' resistor to generator negative. This causes a reversal of current through the series coil and ensures a positive opening impulse to the cut-out.

INSTALLATION

17. The unit should be mounted in a vertical position with the terminal block at the bottom, and placed so that there is no restriction to the free circulation of cooling air.

SERVICING

General

18. General servicing instructions for the voltage regulator unit are given in A.P.4343, Vol.1, Sect.6, Chap.1, where information will be found on changing the carbon pile, and on setting up a regulator which is completely out of adjustment. When any adjustment is made, the regulator must afterwards be subjected to a full test.

19. The cut-out and the two non-polarized relays should be examined to ensure that their contacts close satisfactorily and are not excessively worn or pitted. All components on the unit should be checked for security of mounting, and the tightness of electrical connections.

Adjustment of cut-out

Main contacts

20. Adjust the main contact block (*fig.3*) by means of the adjusting screw, to give an armature gap of 0.005 in. when the main contacts are fully closed by hand. The locking screws should be left just sufficiently slack to permit final adjustments when testing.

Auxiliary contacts

21. Adjust the auxiliary contacts by slackening the locking screws and moving the contact block, so that the minimum contact

gap is 0.012 in. for both the normally open and normally closed contacts. The contacts should then be checked for satisfactory operation when the cut-out is operated by hand.

TESTING

General

22. It is desirable that the following tests should be performed using the correct type of d.c. generator connected to a variable speed test set. The regulator operating coil current should be measured with a suitable ammeter connected in series with the coil and ballast resistors, and the carbon pile resistance by the voltmeter/ammeter method.

23. The test circuit requires an on/off switch and a warning light to be connected as shown in fig.4, a means of applying the generator full load of 75A at 28V, and a 24V battery of not less than 40AH capacity to be connected to terminal 2.

24. The voltage regulator should be adjusted to control at 28V with the operating coil current with the limits of 1.0A to 1.1A.

Regulation test

25. With the control switch set to the off position, run the generator over a speed range so that the carbon pile resistance varies between 2 and 38 ohms. Repeat this cycle and observe that the controlled voltage level is maintained at $28V \pm 0.75V$.

Stability test

26. Run the generator at a speed so that the carbon pile is operating at the maximum resistance of 38 ohms. Set the generator control switch to the on position and switch the full generator load on and off at least three times. Under these conditions the regulator must be critically damped.

27. Following this test, turn the pile compression screw counter-clockwise by $\frac{1}{4}$ turn, and repeat the stability test. At this setting of the pile compression screw

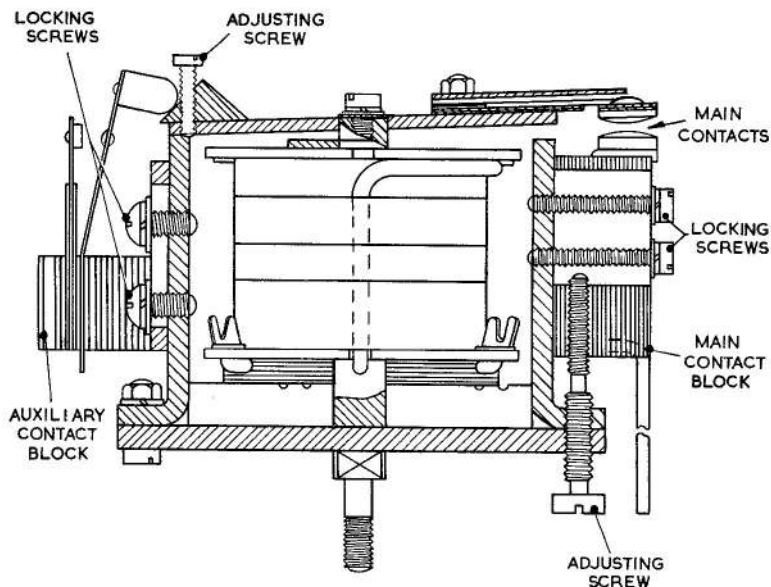

Fig.3. Sectional view of cut-out.

RESTRICTED

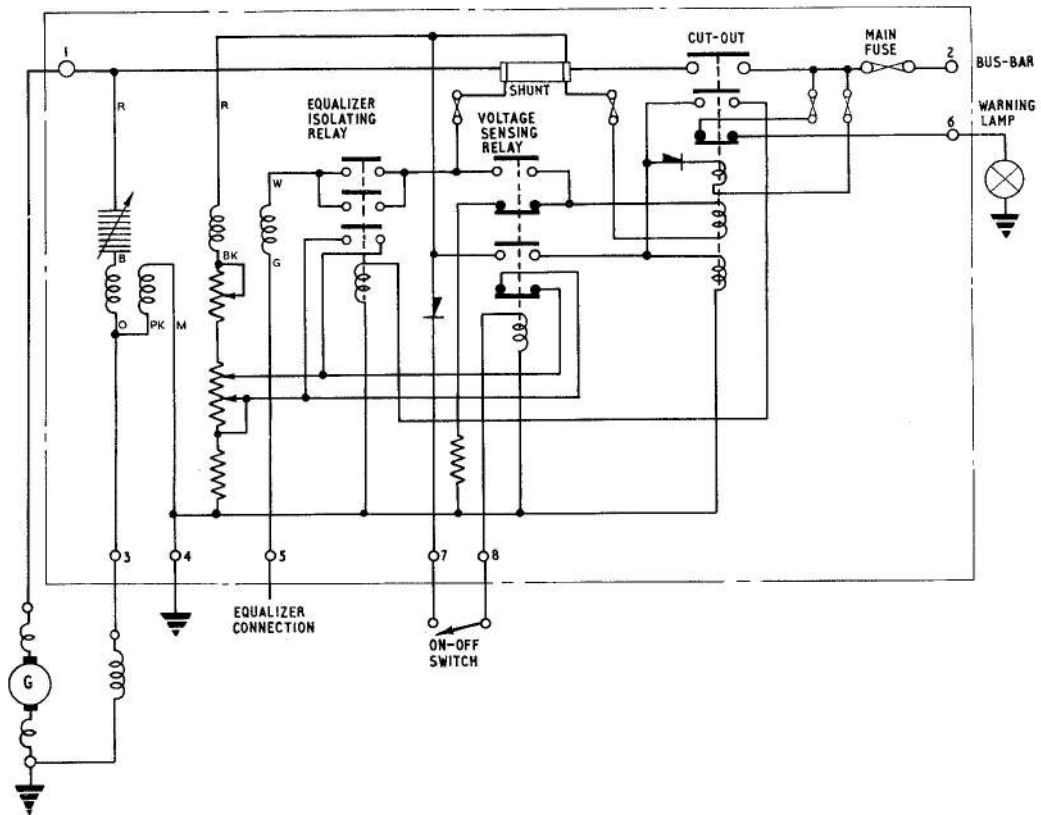

Fig.4. Circuit diagram.

the regulator must respond without tendency to sustained hunting. If the regulator satisfies this test, restore the pile compression screw to its original position, and repeat the regulation test para.25.

Cut-out

28. *Closing test.* Slowly increase the generator speed until the cut-out closes, the differential voltage at cut-in, measured across terminals 1 and 2 should not be greater than 1.2V. This should be adjusted if necessary by means of the screw passing through the auxiliary contact block (fig.3), the screw should then be locked by the

application of black cellulose paint to the thread.

29. *Opening test.* Run the generator at 4000 r.p.m. and slowly reduce the speed until the cut-out opens. Observe that the reverse current at cut-out is between the limits of 10A and 20A. This should be adjusted if necessary by means of the main contact block adjusting screw, the contact block should be locked by tightening the two locking screws.

Testing complete unit

30. (1) Ensure that the battery is switched on, the warning light should be

RESTRICTED

on with the control switch in either position.

- (2) With the control switch in the OFF position, run up the generator to 4000 r.p.m. The voltage sensing relay and equalizer isolating relay should not operate.
- (3) Reduce the generator speed to 1000 r.p.m. and set the control switch to the on position. Slowly increase the speed, and determine that, the voltage sensing relay closes between the limits of 16V to 20V measured at terminal 1, the equalizer isolating relay closes immediately the cut-out closes and the warning light is extinguished.
- (4) Increase the generator speed to 4000 r.p.m. Operate the control switch three times, checking that when switched to the OFF position, the cut-out, equalizer isolating relay and voltage sensing relay all open, and that the warning light comes on.
- (5) With the generator running at 4000 r.p.m. and the control switch in the off position, check that the controlled voltage is 28V measured at terminal 1. Remove the subsidiary fuse which supplies the cut-out differential voltage coil circuit, and operate the voltage sensing relay by hand. The generator voltage should rise by 1.75V to

2.5V when the relay is operated. Adjust if necessary by moving the clamp on the adjustable ballast resistor.

- (6) With the generator running at normal speed and delivering the full load current of 75A measure the mV drop as follows:-
 - (a) The mV drop across the shunt resistor terminals, a reading within the limits of 500 ± 15 mV should be obtained.
 - (b) The mV drop across the cut-out main contacts. The reading should be not greater than 75 mV.
 - (c) The mV drop between terminals 1 and 2. The reading should be not greater than 850 mV.
- (7) With the generator running at normal speed and the full load switched on, check that the cut-out opens and closes when the control switch is operated.

Insulation resistance

31. The insulation resistance should be measured between all terminals connected together and the frame with the unit hot. The minimum permissible reading should be not less than 5 megohms when tested with a 250V insulation resistance tester.

This file was downloaded
from the RTFM Library.

Link: www.scottbouch.com/rtfm

Please see site for usage terms,
and more aircraft documents.

