

## Chapter 5

### VOLTAGE REGULATOR, TYPE 46

#### LIST OF CONTENTS

	Para.		Para.
Introduction ... ..	1	Testing ... ..	8
Description ... ..	3	Regulation test ... ..	11
Servicing ... ..	6	Stability test ... ..	12

#### LIST OF ILLUSTRATIONS

	Fig.		Fig.
Voltage regulator, Type 46 ... ..	1	Test circuit diagram ... ..	2

#### LEADING PARTICULARS

##### Voltage regulator, Type 46

##### Incorporating—

Regulator unit, Type 1046 ... ..	Stores Ref. 5UC/4852
Carbon pile ... ..	Stores Ref. 5UC/2162
Pile resistance range ... ..	... 0.2 to 1.8 ohms
Coil current ... ..	... 0.041 to 0.051 amp.

#### Introduction

1. The voltage regulator, Type 46, is incorporated in the regulator box of the inverter, Type 100B, to maintain the output voltage at 115 volts a.c. (R.M.S.)  $\pm 5$  volts from  $\frac{1}{8}$  load to full load of 120 watts, 0.8 power factor, with a d.c. input between 25 and 28 volts.

2. The regulator is intended to operate in conjunction with a 1,000 ohm fixed ballast resistor, and a 500-ohm variable trimmer resistor. It is designed on the standard carbon pile principle, which is described in A.P.4343, Vol. 1, Sect. 6, Chap. 1.

#### DESCRIPTION

3. The regulator, Type 46 (*fig. 1*), consists of a regulator unit, Type 1046, with the addition of mounting fixtures at each end. It incorporates a carbon pile  $1\frac{1}{2}$  in. long, consisting of thirteen washers 3 mm. thick. Adjustment is made in the normal way by means of the pile compression screw.

4. At the opposite end is the magnet case, enclosing the operating coil. The core is adjustable, any adjustments being made by turning the slotted end in the end plate, after slackening the locking screw.

5. The colour of the regulator leads is shown in *fig. 1*; a circuit diagram of the regulator fitted in the inverter, Type 100B, will be found in Sect. 16, Chap. 7.

#### SERVICING

6. On installation, minor adjustment to the voltage level may be necessary and is made by means of the trimmer resistor on the inverter. Apart from this adjustment, however, the mechanical setting of the regulator should not be interfered with, unless the regulator is definitely suspected of being faulty.

7. General servicing instructions for this type of regulator are given in A.P.4343, Vol. 1, Sect. 6, Chap. 1 and 2. Chap. 1 describes the method of adjusting a regulator which is out of order; if any adjustment is made, the regulator must be fully tested as described in the following paragraphs.

#### Testing

8. The regulator should be connected in a test circuit diagram as shown in *fig. 2*. For test purposes, the Type 46 regulator can be used with the Type 100A inverter and

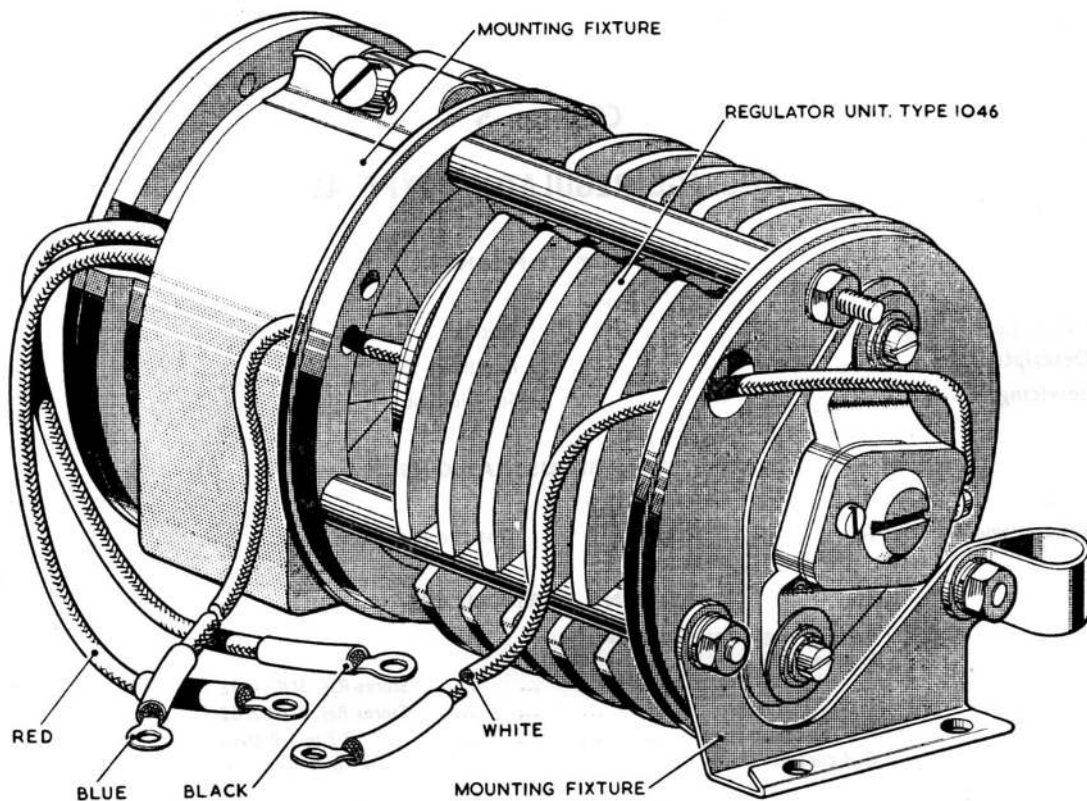

Fig. 1. Voltage regulator, Type 46

Type 12 control panel (with Type 54 regulator disconnected) instead of with the Type 100B inverter.

9. Set the trimmer resistor to within  $\pm 10$  per cent of the mean position of its total travel. The coil current must be 0.046 amp.  $\pm 10$  per cent at 115 volts at 20 deg. C. Ammeter A2 must be removed before proceeding with the tests.

10. Run the regulator and inverter on load for approximately one hour at an input voltage of 28 volts before any readings of controlled voltage are taken.

**Note . . .**

*It is important that all instruments used during the tests should be of industrial portable grade accuracy having a 5 in. or greater scale. The a.c. voltmeter should be of the moving iron type calibrated for use at 400 c/s.*

**Regulation test**

11. With the inverter running on no load, vary the input voltage so that the pile is

operated over the range of 0.2 ohm — 1.8 ohm — 0.2 ohm (all  $\pm 2$  per cent), measured by V1/A1. Over this range the regulator must maintain the a.c. output voltage of the inverter within the limits of 110–120 volts.

**Stability test**

12. To check the stability of the regulator, run the inverter on no load and adjust the input voltage so that the pile resistance is 1.8 ohm  $\pm 2$  per cent. Switch the inverter on and off again under these conditions; the regulator must respond without any tendency to hunt.

13. Immediately following the above test, turn the pile compression screw back  $\frac{1}{16}$ th turn, and repeat the test. Under these conditions the regulator must respond without any tendency to sustained hunting.

14. Provided the regulator satisfies the test in para. 13, restore the original setting of the pile compression screw, and repeat the regulation test.

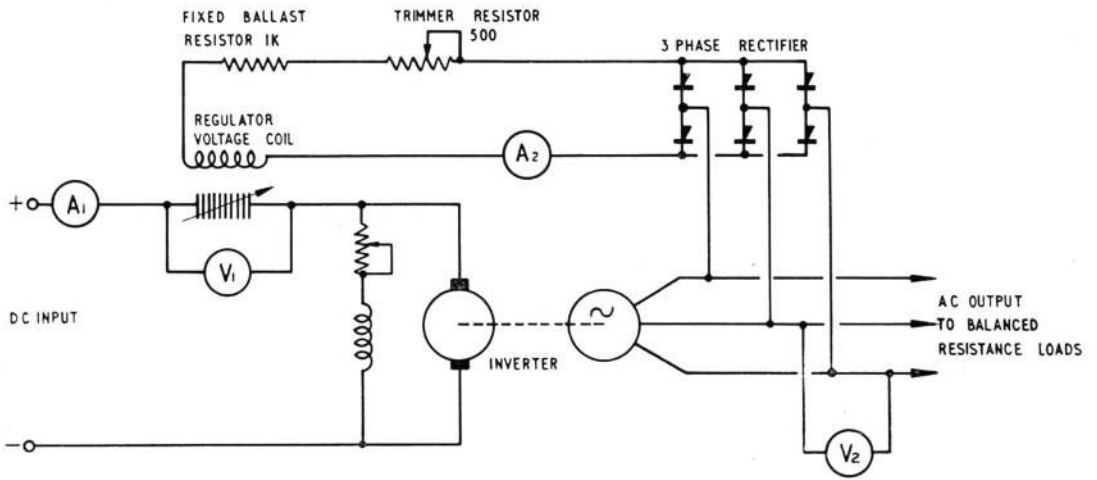

- RECTIFIER BALLAST AND TRIMMER RESISTANCES
- a) EMBODIED IN BASE OF INVERTER TYPE 100 B
  - b) EMBODIED IN CONTROL PANEL TYPE 12 FOR INVERTER TYPE 100 A

Fig. 2. Test circuit diagram

This file was downloaded  
from the RTFM Library.

Link: [www.scottbouch.com/rtfm](http://www.scottbouch.com/rtfm)

Please see site for usage terms,  
and more aircraft documents.

