

Now 1135 - 0771 - 1

Chapter 50

VOLTAGE REGULATOR TYPE 126 (FORMERLY TYPE 23/44018E)

(Completely revised)

LIST OF CONTENTS

	<i>Para.</i>
<i>Introduction</i>	1
Description	2
<i>Installation</i>	6
Servicing	7

LIST OF ILLUSTRATIONS

	<i>Fig.</i>
<i>Voltage regulator Type 126</i>	1
<i>Underside view</i>	2
<i>Circuit diagram</i>	3

LIST OF APPENDICES

	<i>App.</i>
<i>Standard serviceability test for voltage regulator Type 126</i>	A

LEADING PARTICULARS

	Ref. No. 5UC/1032881
Voltage regulator Type 126	
<i>Control voltage</i>	27.5V ± 2½%
<i>Maximum pile loading</i> 78W
<i>Pile resistance range</i>	1.6 to 15 ohms
<i>Operating coil current</i>	0.92A to 0.99A
<i>Operating coil resistance</i>	9.75 ohms (cold)
<i>Ballast resistor (fixed)</i>	10 ohms 15W
<i>Ballast resistor (adjustable)</i>	2 × 12 ohms
<i>Remote trimmer</i> 10 ohms
<i>Equalizing potentiometer</i>	2 ohms 7.5W
<i>Equalizing coil resistance</i> 0.26 ohms
<i>Stabilizing shunt winding</i> 387 ohms

RESTRICTED

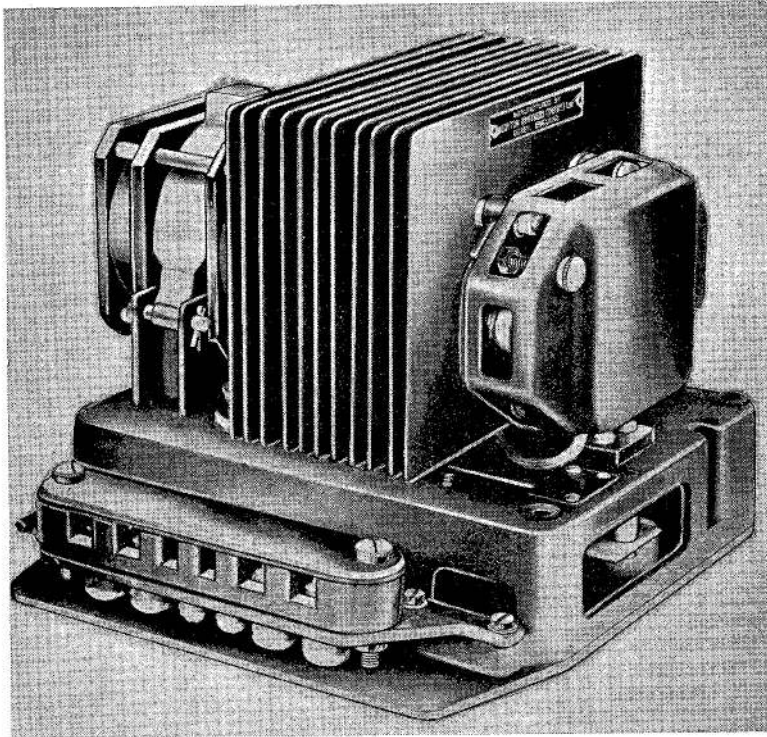

Fig. 1. Voltage regulator, Type 126

Introduction

1. The voltage regulator Type 126 is used to control the output of a d.c. generator Rotax, Type B2104 at $27.5V \pm 2\frac{1}{2}\%$.

DESCRIPTION

2. The regulator fig. 1, is of the single carbon pile type, and in general construction and principle of operation is similar to the standard design, described in A.P.113D-0003-16 (formerly A.P.4343, Vol. 1, Sect. 6, Chap. 1). The voltage unit incorporates a carbon pile which is made up as follows:—

- (1) Pile length, maximum 73 mm., minimum 71 mm.
- (2) 3 mm. washers, minimum quantity 18.
- (3) 0.5 mm. washers, minimum quantity 34.

The carbon washers are assembled with two 0.5 mm. washers between each 3 mm. washer, finishing with a 3 mm. washer at each end.

3. The operating coil is connected in series with the ballast resistors, across the generator output. Additional windings are embodied with the operating coil in order to provide a wide stability margin. Under normal conditions, the shunt and series stabilizing coil counterbalance, but under conditions of transients, due to sudden change of speed or load, the effective ampere turns of the shunt stabilizing winding tend to reduce the total magnetic force, thus exercising a stabilizing influence on the performance of the regulator.

4. An equalizing coil is fitted to allow for load sharing between generators operating in parallel, this coil is such that with 0.5V applied across it in the correct direction, the controlled voltage level is reduced from 27.5V to between 23V and 22.5V. The equalizing potentiometer connected in this circuit is used to balance the load sharing of generators operating in parallel.

5. The remote trimmer is connected across a section of the adjustable ballast resistor, this ensures that in the event of an open circuit in the trimmer or its associated wiring,

RESTRICTED

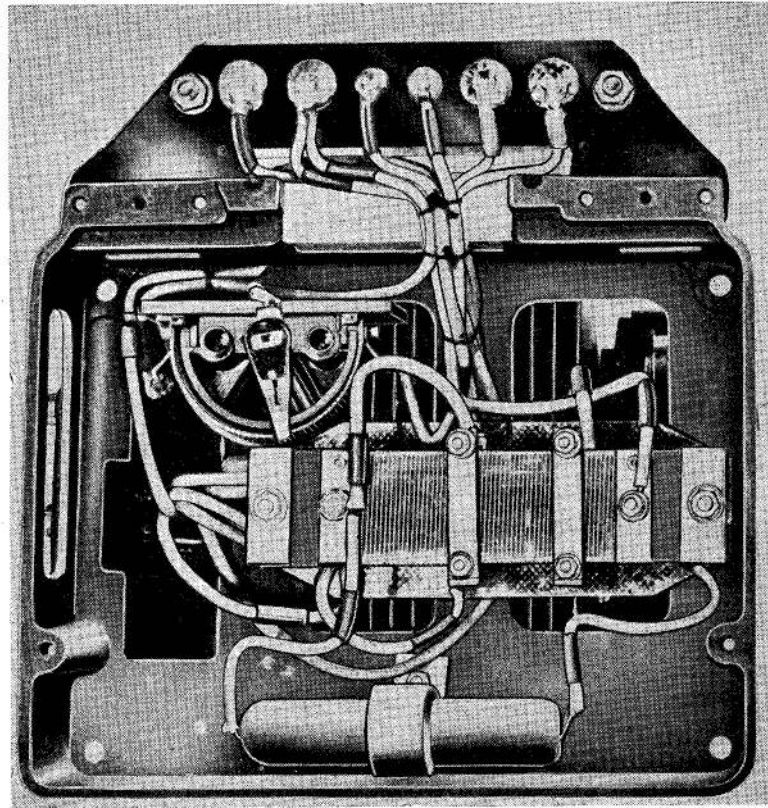

Fig. 2. Underside view

the voltage level is maintained within safe limits.

Installation

6. The regulator is installed with the axis of the carbon pile horizontal and the regulator base in a vertical plane. It is in such a position that there is no restriction to free circulating air through the cooling fins.

SERVICING

7. General servicing instructions for this type of regulator are given in A.P.113D-0003-16 (formerly A.P.4343, Vol. 1, Sect. 6, Chap. 1). This publication contains information on changing the carbon pile and on setting up a regulator which is completely out of adjustment. The latter part of this publication gives general information on repair and reconditioning on this type of regulator. When any adjustment is made, the regulator must afterwards be subjected to a full test.

Note . . .

The correct setting for the pile compression screw of this regulator is in the dip position.

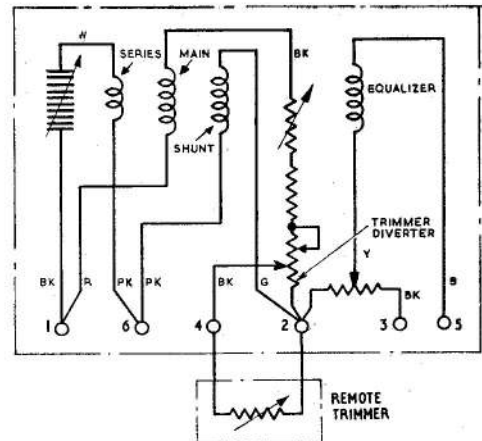

Fig. 3. Circuit diagram

RESTRICTED

)

)

)

)

)

)

Appendix A

STANDARD SERVICEABILITY TEST

for

VOLTAGE REGULATOR, TYPE 126 (FORMERLY TYPE 23/44018E)

LIST OF CONTENTS

	Para.		Para.
<i>Introduction</i>	1	<i>Regulation test</i>	5
<i>Test equipment</i>	2	<i>Stability test</i>	7
Test procedure		<i>Equalizing test</i>	9
<i>General</i>	3	<i>Insulation resistance test</i>	10

LIST OF ILLUSTRATIONS

	Fig.
<i>Test circuit diagram</i>	1

Introduction

1. The following tests should be applied to the regulator whenever it is necessary to determine its serviceability.

Test equipment

2. The following items of test equipment will be required when testing the regulator.

- (1) Generator, Type 501, Rotax, Type B2104.
- (2) Remote trimmer, Ref. No. 5UC/5210.
- (3) Variable resistor (R1) 18 ohm, 2 amp.
- (4) Variable resistor (R2).
- (5) Variable resistor (R3) 18 ohm, 2 amp.
- (6) Switch S.P.10A (S1).
- (7) Switch S.P.3A (S2).
- (8) Switch S.P.10A (S3).

(9) Multimeter Type 12889 (V1), Ref. No. 5QP/17447.

(10) Voltmeter 0-40V (V2), Ref. No. 5Q/234.

(11) Voltmeter 0-3V (V3).

(12) Ammeter 0-20A (A2).

(13) Ammeter 0-3A (A3).

(14) Battery, dry, 4.5V.

(15) Insulation resistance tester Type C.

TEST PROCEDURE

General

3. The regulator Type 126 and test equipment should be connected as shown in the circuit diagram fig. 1; this diagram shows a regulator connected to a generator Type 501, Rotax Type B2104, but if this generator is not available any generator which is used with this regulator may be substituted. Switch S1 should be closed for all tests except as described in the stability test.

RESTRICTED

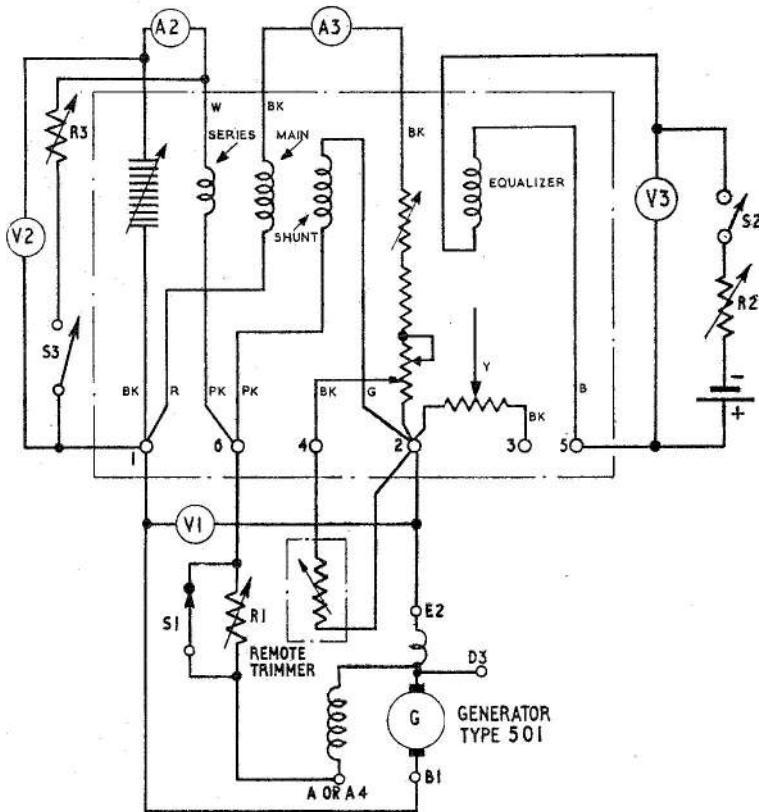

Fig. 1. Test circuit diagram

Switches S2 and S3 should be open except as described in the relevant paragraphs.

4. With the regulator cold, run the generator at normal speed and on no-load. Set the remote trimmer in the electrical mid position. The output voltage at V1 should be 27.5V and the operating coil current A3 within the limits of 0.92A and 0.99A. If this voltage and current is not obtained refer to A.P.113D-0003-16, para. 40-45 (formerly A.P.4343, Vol. 1, Sect. 6, Chap. 1, para. 40-45).

Note . . .

The correct setting for the pile compression screw on this regulator is in the dip position.

Regulation test

5. Run the generator over a speed range so that the pile resistance, as measured by

the ratio $V2/A2$, varies smoothly from 1.6 to 15 to 1.6 ohms. Repeat this cycle, and observe that the controlled voltage is maintained within the limits of $27.5V \pm 2\frac{1}{2}\%$.

Note . . .

(1) *The diverter resistance R3 may be switched in circuit if it is not possible to obtain the correct pile resistance variation by speed control.*

(2) *The diverter resistance R3 should always be switched in or out of circuit at its maximum value.*

6. With the generator running at normal speed observe that V1 indicates 27.5V. The remote trimmer diverter resistance should be adjusted so that the controlled voltage level V1 rises to between 29.4V and 29.6V when the remote trimmer is open-circuited.

RESTRICTED

Stability test

7. Run the generator so that the pile resistance as measured by the ratio V_2/A_2 is 15 ohms. Open switch S1 and adjust R1 so that the pile resistance as measured by the ratio V_2/A_2 is 1.6 ohms. Close switch S1. Open and close S1 at least three times. Under these conditions the regulator should be critically damped.

8. Provided the regulator satisfies the test in para. 7 turn the pile compression screw counter-clockwise $\frac{1}{8}$ turn, repeat the test in para. 7. At this setting of the pile compression screw the regulator should respond without tendency to sustained hunting. Provided the regulator satisfies this test, restore the pile compression screw to its original

setting and repeat the regulation test para. 5.

Equalizing test

9. Close switch S2 and adjust R2 so that V3 reads 0.5V. Open switch S2 and run the generator at normal running speed. Observe that the output voltage at V1 is 27.5V. When the voltage is applied by closing the switch S2, the line voltage V1 should be reduced from 27.5V to between the limits of 23.0V and 22.5V.

Insulation resistance test

10. Using the insulation resistance tester Type C measure the insulation resistance between all connecting leads and the frame. The reading should be not less than 5 megohms.

RESTRICTED

C

CC

CC

C

CC

This file was downloaded
from the RTFM Library.

Link: www.scottbouch.com/rtfm

Please see site for usage terms,
and more aircraft documents.

