

On Receipt of AP 113D - 0711-16

F.S./1

Remove this Chapter

A.P.4343B, Vol. 1, Book 1, Sect. 1, Chap. 61  
A.L.37, Aug. 65

Not used

## Chapter 61

# TRANSISTOR VOLTAGE REGULATOR, DELCO-REMY 9000591

### LIST OF CONTENTS

	Para.		Para.
<i>Introduction</i> ... ..	1	<b>Servicing</b>	
<b>Description</b>		<i>General</i> ... ..	11
<i>General</i> ... ..	2	<i>Dismantling</i> ... ..	12
<i>Housing</i> ... ..	3	<i>Bay servicing</i> ... ..	13
<i>Component assembly board</i> ... ..	4	<i>Assembly</i> ... ..	18
<i>Transistors</i> ... ..	6	<i>Testing</i> ... ..	19
<b>Operation</b> ... ..	7		

### LIST OF ILLUSTRATIONS

	Fig.
<i>General view of voltage regulator</i> ... ..	1
<i>Exploded view of regulator</i> ... ..	2
<i>Circuit diagram</i> ... ..	3

### LIST OF APPENDICES

	App.
<i>Standard serviceability test</i> ... ..	A

### LEADING PARTICULARS

<i>Voltage Regulator, Delco-Remy 9000591</i> ... ..	Ref. No. 5UC/7835
<i>Operating voltage</i> ... ..	... 18 to 28.5V d.c.
<i>Generator regulated voltage</i> ... ..	... 28 ± 0.5V d.c.
<i>Operating current</i> ... ..	... 2.9 to 4.2A
<i>Weight</i> ... ..	... 2 lb.
<i>Associated generator, Delco-Remy 1117086</i> ... ..	Ref. No. 136H/381

#### Introduction

1. The transistor voltage regulator, Delco-Remy 9000591 is used to limit the voltage of the Delco-Remy generator 1117086 at a pre-set level, by controlling the generator field current.

#### DESCRIPTION

##### General

2. The regulator unit consists of a housing and a component assembly board, the assembly board being attached to the housing with three securing screws. The assembly is sealed with a rubber gasket and

**RESTRICTED**

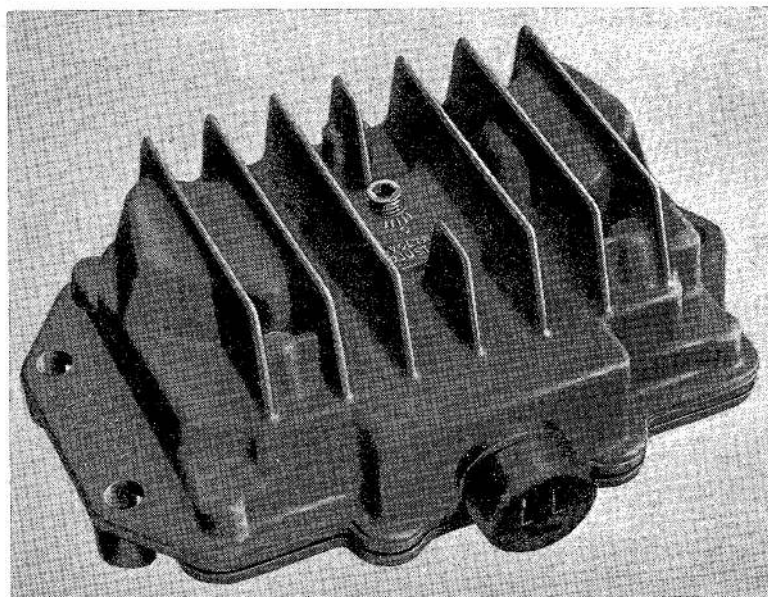

**Fig. 1. General view of voltage regulator**

a cover that is ribbed to provide additional heat dissipation. Connection into the external circuit is made by means of a 3-pin polarized socket at the side of the regulator.

#### **Housing**

**3.** A light-alloy case, housing the component assembly, is provided with external finning for heat dissipation, and a recess in the finning incorporates an Allen screw, which, when removed, gives access for voltage adjustment. Internally the top side of the housing incorporates integral positive and negative voltage adjustment limit stops, and two recesses to house the power and driver transistors.

#### **Component assembly board**

**4.** The component assembly consists of a panel board and an aluminium heat transfer plate, separated by insulators. Mounted on the undersurface of the panel board and in contact with the regulator circuitry impressed on the top surface, are the following components:—

- (1) Emitter-base resistor
- (2) Driver-collector resistor
- (3) Step voltage resistor
- (4) Divider resistor
- (5) Feedback resistor

- (6) Feedback capacitor
- (7) Filter capacitor
- (8) Field discharge diode
- (9) Zener diode
- (10) Back bias diode
- (11) Suppression diode
- (12) Potentiometer.

**5.** The potentiometer is provided with a nylon adjustment arm, which protrudes through the heat transfer plate below the adjustment access hole.

#### **Transistors**

**6.** The power and driver transistors are mounted on the top surface of the heat transfer plate, insulated from it by mica washers, and secured to the panel board with screws, which pass through the insulators and the plate. The transistor leads pass through holes in the plate to connect to the circuitry on the panel board.

#### **OPERATION**

**7.** Current from the generator enters the regulator at the positive terminal and passes through diode D1 to the emitter of transistor TR1. A small amount of emitter-base current flows through resistor R2 to the negative terminal and earth, and allows

**RESTRICTED**

full generator field current to flow through the emitter-collector, field terminal, field windings and to earth. Diode D3 prevents the current leaking to earth through the negative terminal.

8. With this condition of full field current, the generator voltage will increase rapidly as the generator speed increases, and the current through resistors R3 and R6 will also increase. The resultant voltage drop across these resistors is also impressed upon the parallel circuit through the emitter-base of transistor TR2 and diode D2 to resistor R4. When the voltage across diode D2 reaches the value as set by the potentiometer, the diode breaks down, allows current to pass to resistor R4, and emitter-base current to flow in transistor TR2. With the resultant decrease in resistance of the emitter-collector, current is free to flow from the positive terminal through the emitter-base and emitter-collector of transistor TR2 to resistor R2 and thence to earth. Voltage drop across resistor R1 increases as does the voltage potential at the base of transistor TR1, and a reverse bias condition is created in transistor TR1. Emitter-base current ceases to flow and a high resistance is transferred to the emitter-collector to stop field current flow through the emitter-collector of transistor TR1. Although field current is suddenly stopped at transistor TR1, the current in the field windings does not immediately fall to a zero value, due to field inductance, and the circuit necessary for current flow is obtained through diode D3.

9. With decreasing field current, the generator voltage decreases and in consequence the voltage across diode D2 decreases to a value below breakdown voltage. The current flow through diode D2 to resistor R4 stops, and emitter-base current in transistor TR2 also stops, and high resistance is transferred to the emitter-collector circuit to prevent current flow. With less current through resistor R1, its voltage drop decreases and re-establishes emitter-base current and maximum emitter-collector current in transistor TR1. Generated voltage then increases, until the breakdown value across diode D2 is reached, and the cycle repeated.

10. Overheating of the transistors is prevented by capacitor C1, which reduces to a minimum the length of time required for the field voltage to change between maximum and minimum values. Capacitor C2 improves the regulator accuracy by reducing the magnitude of the small system-voltage variations which appear across resistors R3 and R6. Resistor R2 prevents leakage current from emitter to collector in transistor TR2. Diode D4 is fitted as a suppression device.

## SERVICING

### General

11. Apart from visually examining the regulator for obvious defects, cleanliness and security of electrical connections, no in-situ servicing is possible.

### Dismantling

12. To dismantle the regulator the following procedure should be adopted:—

- (1) Remove the seal from the seal cup
- (2) Remove the six screws securing the cover plate and rubber gasket, and remove cover plate and gasket.
- (3) Remove the three securing screws and remove the panel board complete with heat transfer plate, transistors, grommet and socket.

### Bay servicing

#### Cleaning

13. The housing and cover plate should be cleaned with lead-free petrol or an approved cleaning agent, and thoroughly dried, using dry compressed air or lint-free cloth. Care should be taken not to allow the solvent to come into contact with the rubber gasket.

14. Since the regulator is completely sealed, the component assembly should not need cleaning, but the top side of the heat transfer plate should be wiped dry with lint-free cloth to remove all grease.

#### Examination

15. The regulator should be examined for the following defects:—

**RESTRICTED**

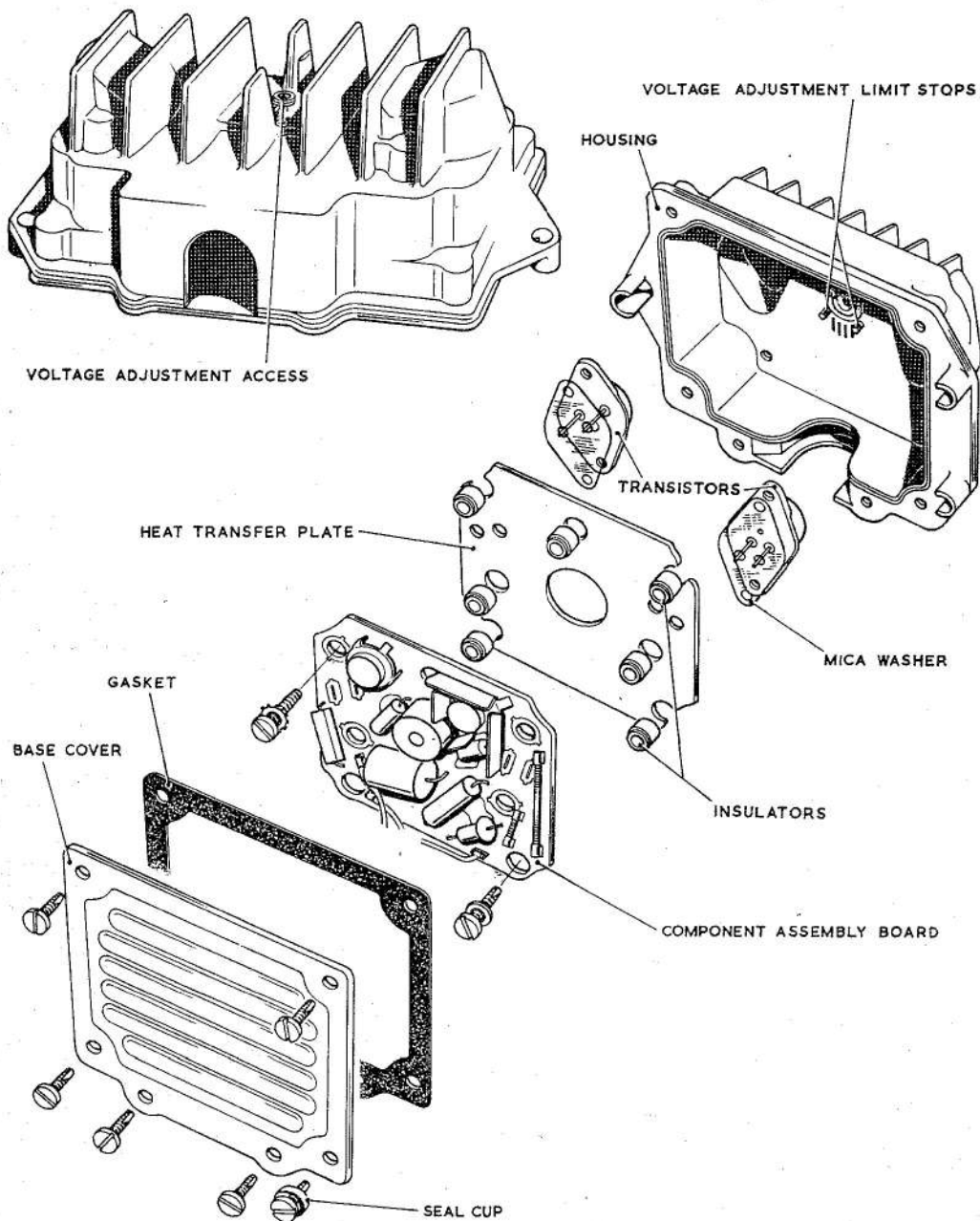

Fig. 2. Exploded view of regulator

- (1) The housing for broken or cracked fins and for signs of excessive heat.
- (2) The component assembly for signs of excessive heat and short circuiting.
- (3) The cables, grommet and socket

for damage, ensuring that the transistor attachment screws are secure, and that the nylon adjustment arm is undamaged and secure in the potentiometer.

- (4) The cover plate and rubber gasket for damage and signs of excessive heat.

**RESTRICTED**

*Transistor renewal*

16. To renew a transistor the following procedure should be adopted:—

- (1) Remove the two securing screws and star washers, and remove the transistor, withdrawing the pins carefully from their sockets in the printed circuit, and through the holes in the transfer plate.
- (2) Ensure the mica insulation washers are undamaged and refit in position on the heat transfer plate.
- (3) Position the new transistor on the mica washer with the pins passing through the heat transfer plate, to locate correctly in the sockets in the printed circuit.
- (4) Refit the two securing screws and

star washers, and tighten evenly, taking care not to overtighten.

*Component renewal*

17. The renewal of components other than the transistors will entail the breaking and making of soldered joints. Unsoldering or soldering time must be limited to a minimum, as excessive heat may damage the printed circuit and component parts. The soldering iron used should be rated at 50 watts or less.

**Assembly**

18. To assemble the regulator the following procedure should be adopted:—

- (1) Lower the component assembly into the housing, ensuring that the transistors fit into their recesses, and that the nylon adjustment arm is located correctly between the voltage adjustment stops.

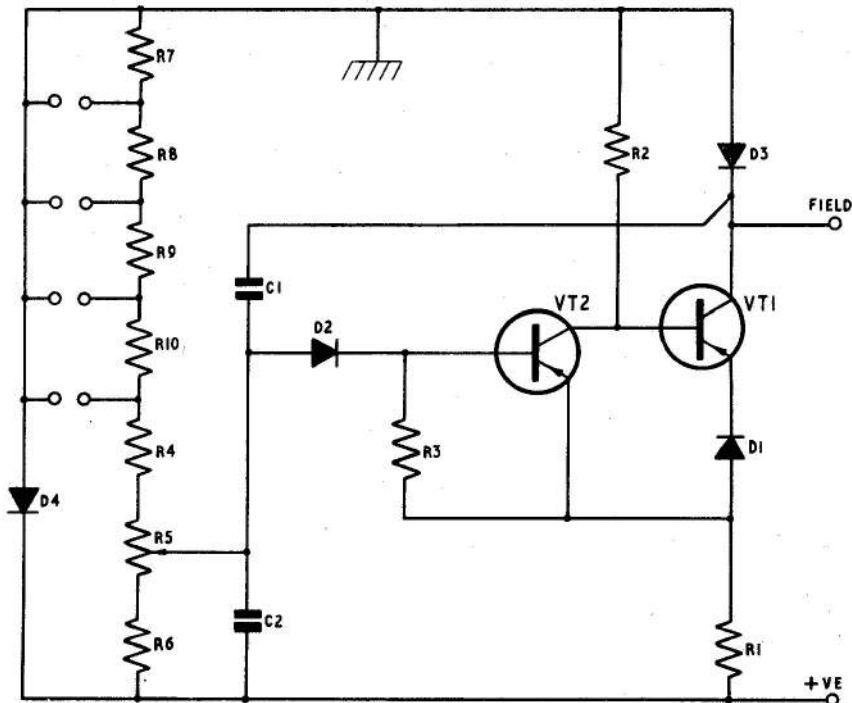

Fig. 3. Circuit diagram

**RESTRICTED**

(2) Secure the component assembly to the housing with three screws and plain washers.

(3) Fit the grommet and socket to the housing cut-out.

(4) Refit the cover plate and sealing gasket and secure with six screws.

(5) On satisfactory completion of testing seal the regulator using the seal cup provided.

#### **Testing**

19. Details of the tests which should be applied to the regulator to determine its serviceability, will be found in Appendix A to this chapter.

**RESTRICTED**

**APPENDIX A**

**STANDARD SERVICEABILITY TEST**

**FOR**

**TRANSISTOR VOLTAGE REGULATOR, DELCO-REMY 9000591**

**Introduction**

1. The following tests should be applied to the voltage regulator whenever its serviceability is suspect or before it is put into Service.

**Test equipment**

2. The following items of test equipment should be available when testing the regulator:—

- (1) Slave generator, Delco-Remy 1117086.
- (2) Voltmeter, 0-30V d.c.
- (3) Ammeter, 0-100A d.c. (A1).
- (4) Ammeter, 0-5A d.c. (A2).
- (5) Variable resistive load capable of dissipating 2.5kw.

**TEST PROCEDURE****Note . . .**

- (1) *Care must be taken whilst connecting the test equipment that the polarity is correct, otherwise damage to the regulator will result.*
- (2) *High voltage insulation resistance testers must not be used to check the insulation resistance of the regulator.*
- (3) *The slave generator must not be run on open circuit.*

3. Connect the test equipment as shown in the test circuit diagram (fig. 1). Run the generator at the speeds and loads detailed below, and check that the generator output voltage and field current are maintained within the specified limits.

Speed	Load	Voltage	Field current	Duration
3000 rev/min	20A	$28 \pm 0.5V$	2.9 to 4.0A	10 min.
3000 rev/min	58A	$28 \pm 0.5V$	2.9 to 4.0A	10 min.
6000 rev/min	20A	$28 \pm 0.5V$	2.9 to 4.0A	2 min.
6000 rev/min	71A	$28 \pm 0.5V$	2.9 to 4.0A	2 min.
9000 rev/min	20A	$28 \pm 0.5V$	2.9 to 4.0A	2 min.
9000 rev/min	73A	$28 \pm 0.5V$	2.9 to 4.0A	2 min.

4. During the tests detailed in para. 3, check that the output voltage of the generator can be varied above and below the

nominal 28V, by adjusting the regulator potentiometer. Reset the output voltage to  $28 \pm 0.5V$  on completion of the check.

**RESTRICTED**

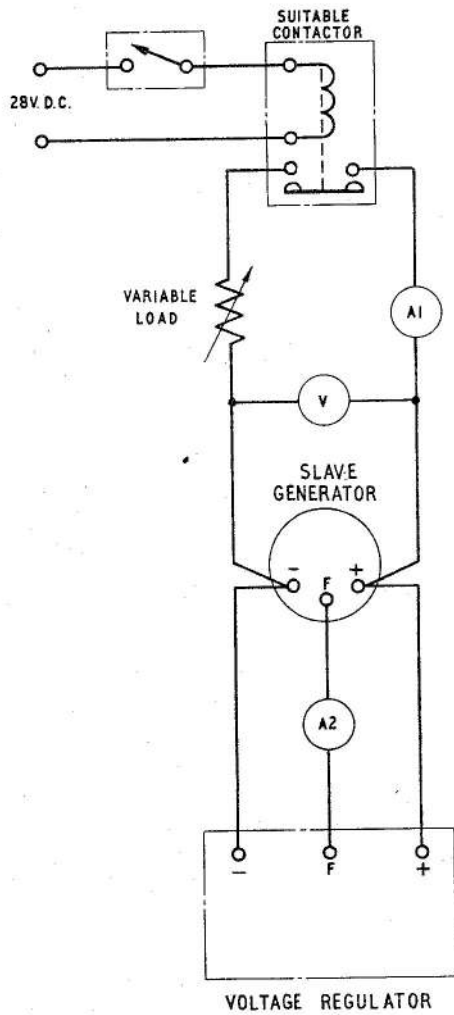

Fig. 1. Test circuit diagram

**RESTRICTED**

This file was downloaded  
from the RTFM Library.

Link: [www.scottbouch.com/rtfm](http://www.scottbouch.com/rtfm)

Please see site for usage terms,  
and more aircraft documents.

