

## Chapter 8

### VOLTAGE REGULATOR, TYPE 96

#### LIST OF CONTENTS

	Para.		Para.
Introduction ... ..	1	Testing of regulator ... ..	10
Description ... ..	3	Regulation test ... ..	12
Servicing ... ..	9	Stability tests ... ..	13

#### LIST OF ILLUSTRATIONS

	Fig.		Fig.
Voltage regulator, Type 96 ... ..	1	Circuit diagram ... ..	3
Sectional view of regulator ... ..	2	Test circuit diagram ... ..	4

#### LEADING PARTICULARS

<b>Voltage regulator, Type 96</b> ... ..	Ref. No. 5UC/6031
Controlled voltage ... ..	28 volts $\pm$ 0.75 volts
Maximum pile loading ... ..	... .. 230 watts
Pile resistance range ... ..	... .. 0.5 to 4.5 ohms
Carbon pile ... ..	Ref. No. 5UC/6152
Operating coil current ... ..	... .. 2.0 to 2.2 amp.
Operating coil resistance at 20 deg. C. ... ..	... .. 4 ohms
Shunt stabilizing coil resistance ... ..	... .. 160 ohms
Ballast resistor (7.5 ohms, 40 watts) ... ..	Ref. No. 5UC/6094
Trimmer diverter (5.0 ohms, 10 watts) ... ..	Ref. No. 5UC/6158
Remote trimmer (5 ohms, 7.5 watts) ... ..	Ref. No. 5UC/6159
Pile series resistor (0.1 ohm, 40 watts) ... ..	Ref. No. 5UC/6157
Dimensions ... ..	8.875 in. $\times$ 7 in. $\times$ 7.75 in.
Weight ... ..	14 lb.

#### Introduction

1. The voltage regulator, Type 96, is used to control the output of the 15 KVA a.c. generator, Type 157, at 28 volts  $\pm$  0.75 volts.

2.  $\blacktriangleleft$  The 208-volt, 400 c/s, 3-phase output of the alternator is stepped down and rectified in the transformer unit (described in Book 3, Sect. 18, Chap. 3 of this publication), to supply the operating coil of the voltage regulator at the 28-volt level. The carbon pile of the voltage regulator is in series with the 28-volt d.c. field winding of the alternator.  $\blacktriangleright$

#### DESCRIPTION

3. This regulator (*fig. 1*) is of the multi-pile type, provided with four carbon piles connected in series-parallel. Apart from the modified construction to accommodate the four piles, the voltage regulator is similar in construction and principle of operation to the

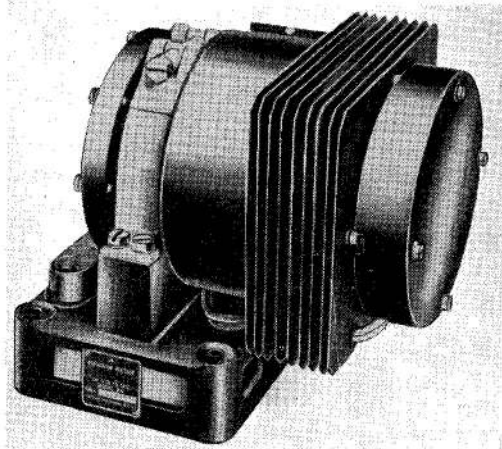

Fig. 1. Voltage regulator, Type 96

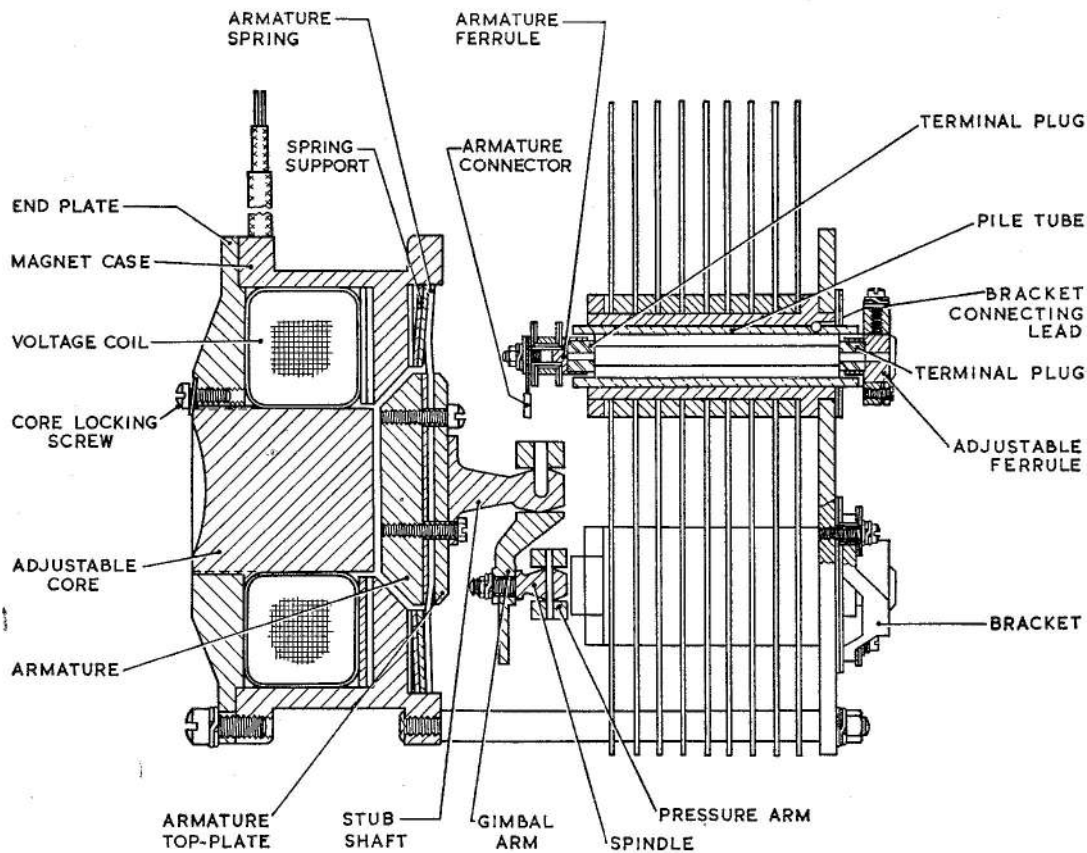

Fig. 2. Sectional view of regulator

single-pile type described in A.P.4343, Vol. 1, Sect. 6, Chap. 1.

4. To mount the four piles, a stub shaft projects from the armature clamp plate (fig. 2). A gimbal arm, pinned to this stub axle, carries two pressure arms which are pinned to spindles projecting from the ends of the gimbal arm. At the ends of the pressure arms are fitted brass ferrules which are insulated from the arms by mica. The ferrules house carbon terminal plugs which contact the piles. A strap connector links the pair of ferrules on each pressure arm.

5. At the other end of the unit, each pile bracket is screwed to the end plate and is insulated from it by mica washers. Each pile is fitted with its own terminal plug, adjustable ferrule, compression and locking screws, and lead connecting screw. The assembly is protected by a cover which is attached to the end plate by four screws.

6. The four ceramic tubes, housing the pile

stacks, are enclosed within a finned cooler which dissipates the heat generated by the stacks. ◀ Each pile is 2-6 in. long, and consists of nineteen 3-mm. washers and nine 1-mm. washers. These are arranged with two 3-mm. washers between each 1-mm. washer, with two 3-mm. washers at one end and one 3-mm. washer at the other end. ▶

7. The regulator unit and a moulded terminal block are mounted on the top plate of a rectangular base plate provided with four fixing holes, beneath which are the pile series, ballast, and trimmer diverter resistors. A remote trimmer (5 ohms,  $7\frac{1}{2}$  watts) is connected across terminals 4 and 6, i.e., across the trimmer diverter resistor. This ensures that in the event of open-circuiting of one of the trimmer leads, the voltage level is still maintained within safe limits.

8. Series and shunt stabilizing windings are incorporated in the regulator unit to ensure stability of the regulator under transient

**RESTRICTED**

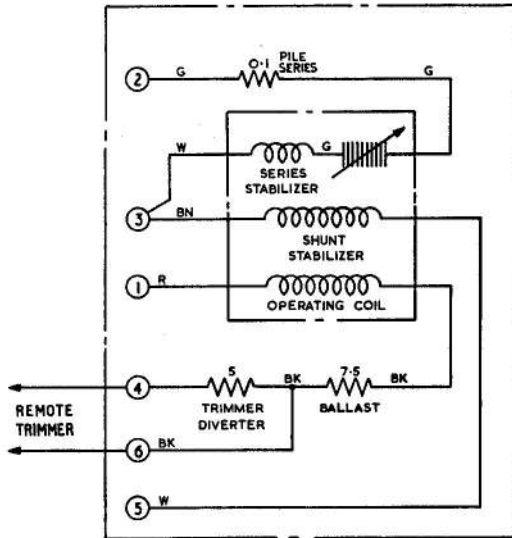

Fig. 3. Circuit diagram

conditions caused by speed or load fluctuations in the generator output, or by switching of the generator field. They are connected as shown in the circuit diagram in fig. 3.

#### SERVICING

9. General servicing instructions for this type of regulator are given in A.P.4343, Vol. 1, Sect. 6, Chap. 1. That chapter describes the fitting of a new pile stack, and the preliminary mechanical adjustment for a regulator which is completely out of order. When any adjustment is made, the regulator must afterwards be subjected to full test.

#### Testing of regulator

10. ◀ It is preferable that the regulator should be tested in conjunction with the a.c. generator, Type 157 and transformer-rectifier unit, Type 2. If these are not available, however, a test may be carried out using a d.c. generator of suitable characteristics, such as Type P3, U0, 501, 515, or 517, connected as shown in the circuit diagram in fig. 4. ▶

11. Disconnect and insulate the green lead from the pile end bracket, and substitute the test lead connected to an external switch (fig. 4). With the stabilizing windings disconnected by switching over to the test lead, the regulator must be adjusted to control the generator output at 28 volts, with the coil current shown on A1 adjusted to within the limits of 2.0 and 2.2 amp. cold.

#### Regulation test

12. Run the generator at constant speed, and by variation of the series and diverter resistors, increase the pile resistance as measured by V2/A2 smoothly from 0.5 ohms to 4.5 ohms, and then decrease to 0.5 ohms. Repeat this cycle, and over this cyclic variation of pile resistance, the controlled voltage V1 must be maintained at 28 volts  $\pm$  0.75 volts.

#### Note . . .

*It is important that the diverter resistor should always be switched in or out at its maximum value.*

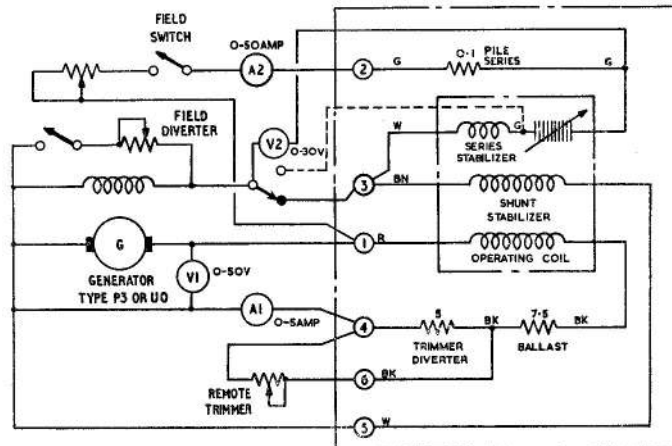

Fig. 4. Test circuit diagram

*Stability tests*

**13.** With the stabilizing windings connected in circuit, and with the pile resistance adjusted to the maximum value of 4.5 ohms, switch the generator field on and off at least three times. Under this condition the regulator must be critically damped.

**14.** Following the test in para. 13, slacken each pile compression screw  $\frac{1}{4}$  turn, i.e.,

equivalent to 0.009 in. pile movement, and repeat the stability test. At this setting of the pile compression screws, the regulator must respond without tendency to sustained hunting.

**15.** Provided the regulator satisfies the test in para. 14, restore each pile compression screw to its original setting, and repeat the regulation test.

This file was downloaded  
from the RTFM Library.

Link: [www.scottbouch.com/rtfm](http://www.scottbouch.com/rtfm)

Please see site for usage terms,  
and more aircraft documents.

