

Chapter 9

VOLTAGE REGULATOR, TYPE E2

LIST OF CONTENTS

	Para.		Para.
Introduction	1	Regulation test	6
Description	2	Alternative procedure	9
Servicing	4	Stability test	10
Testing	5	Checking a new regulator	13

LIST OF ILLUSTRATIONS

	Fig.		Fig.
Circuit diagram	1	Test circuit diagram	2

LEADING PARTICULARS

Voltage regulator, Type E2	Stores Ref. 5UC/410
Coil current	0.14 to 0.155 amp.
Carbon pile	Stores Ref. 5UC/1021
Pile resistance range	5 to 90 ohms
Trimmer resistor (55 ohms)	Stores Ref. 5UC/3436
Ballast resistor (300 ohms)	Stores Ref. 5UC/306

Introduction

1. The voltage regulator, Type E2, is normally fitted to the control panel, Type 4, for the regulation of generators Types R and S at a nominal output of 80 volts a.c.

DESCRIPTION

2. This regulator is similar to the earlier Type E1T except that an additional 2-way terminal block is fitted. This enables a connection to be made to the rectified a.c. output from the generator to the remote operation relay in the control panel, Type 4.

3. The regulator incorporates a pile 1.5 in. long, made up of a minimum of 76 washers 0.5 mm. thick. A circuit diagram is given in fig. 1, and general information on this type of regulator will be found in A.P.4343, Vol. 1, Sect. 6, Chap. 2.

SERVICING

4. General servicing instructions for this type of regulator are given in A.P.4343, Vol. 1, Sect. 6, Chap. 1 and 2. Chap. 1 describes the method of adjusting a regulator which is out of order; if any adjustment is made, the regulator must be fully tested as described in the following paragraphs.

Testing

5. Connect the regulator in the test circuit as shown in fig. 2, the generator used being a Type R (Stores Ref. 5UA/1271) excited from a 28-volt supply. For all tests the adjustable arm of the trimmer resistor is to be in the mid position and the speed of the generator is to be maintained at 4,000 r.p.m. unless otherwise stated.

Regulation test

6. Adjust the diverter and series resistors

(A.L.1, Aug. 57)

so that the pile resistance does not exceed 2 ohms when the generator is running at a speed of 4,000 r.p.m. and is connected to a non-inductive load set for 6.25 amp. at 85 volts.

7. The generator is to be stopped and re-started, and the pile resistance is to be increased from 2 ohms to 90 ohms, and then decreased to 5 ohms, by further adjustment of the diverter and series resistors, and readings of line voltage are to be taken, on voltmeter V1, over the range of values of pile resistance, increasing from 5 ohms to 90 ohms and then decreasing to 5 ohms. Under these conditions, the readings must not vary by more than 3.5 volts, and must lie between the limits of 81 volts and 86 volts.

variation of pile resistance called for in the regulation tests can then be obtained by running the generator on no load and varying its speed from 3,000 r.p.m. to 6,000 r.p.m. approximately.

Stability test

10. To check stability of the regulator, the series resistor is to be short-circuited, the diverter resistor open-circuited, and the full load of the generator switched on and off at generator speeds of 5,000 r.p.m. and 6,000 r.p.m. Under these conditions, the regulator must be critically damped.

11. Immediately following the above test, slacken the pile compression screw $\frac{1}{8}$ th turn (corresponding to a pile movement of 0.0045

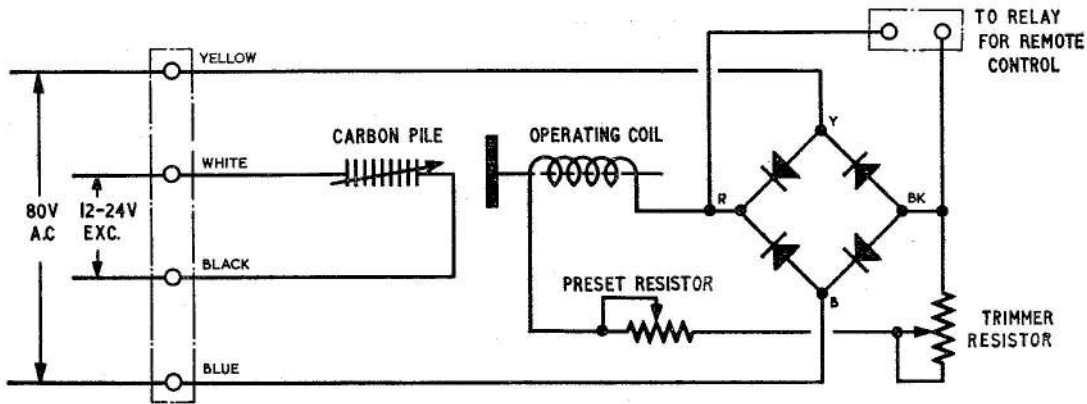

Fig. 1. Circuit diagram

Note . . .

The variation of pile resistance must be made smoothly. To facilitate this, the diverter resistor must always be switched in and out at position of maximum resistance.

8. The pile resistance is then to be increased from the bottom value of 5 ohms to 90 ohms and then decreased to 5 ohms, and readings of line voltage taken on voltmeter V1. Under these conditions, the readings must not vary by more than 3 volts, and must lie between the limits of 81 volts and 86 volts.

Alternative procedure

9. If a variable speed drive, giving a range of generator speeds from 3,000 r.p.m. to 7,000 r.p.m., is available, then the diverter and series resistors are not necessary. The

in.), and repeat the test given in para. 10. Under this condition, the regulator must respond and settle without sustained hunting.

Note . . .

The $\frac{1}{8}$ th turn quoted above is a minimum.

12. Provided the regulator satisfies the test given in para. 11, the original setting is to be restored and the regulation test given in para. 6 to 8 repeated.

Checking a new regulator

13. The full tests are not necessary for a new regulator. It can be tested as follows, by connecting it in the test circuit as shown in fig. 2, but without the series and diverter resistors.

14. Run the generator at 4,000 r.p.m. and at 6,000 r.p.m., first on no load and then with

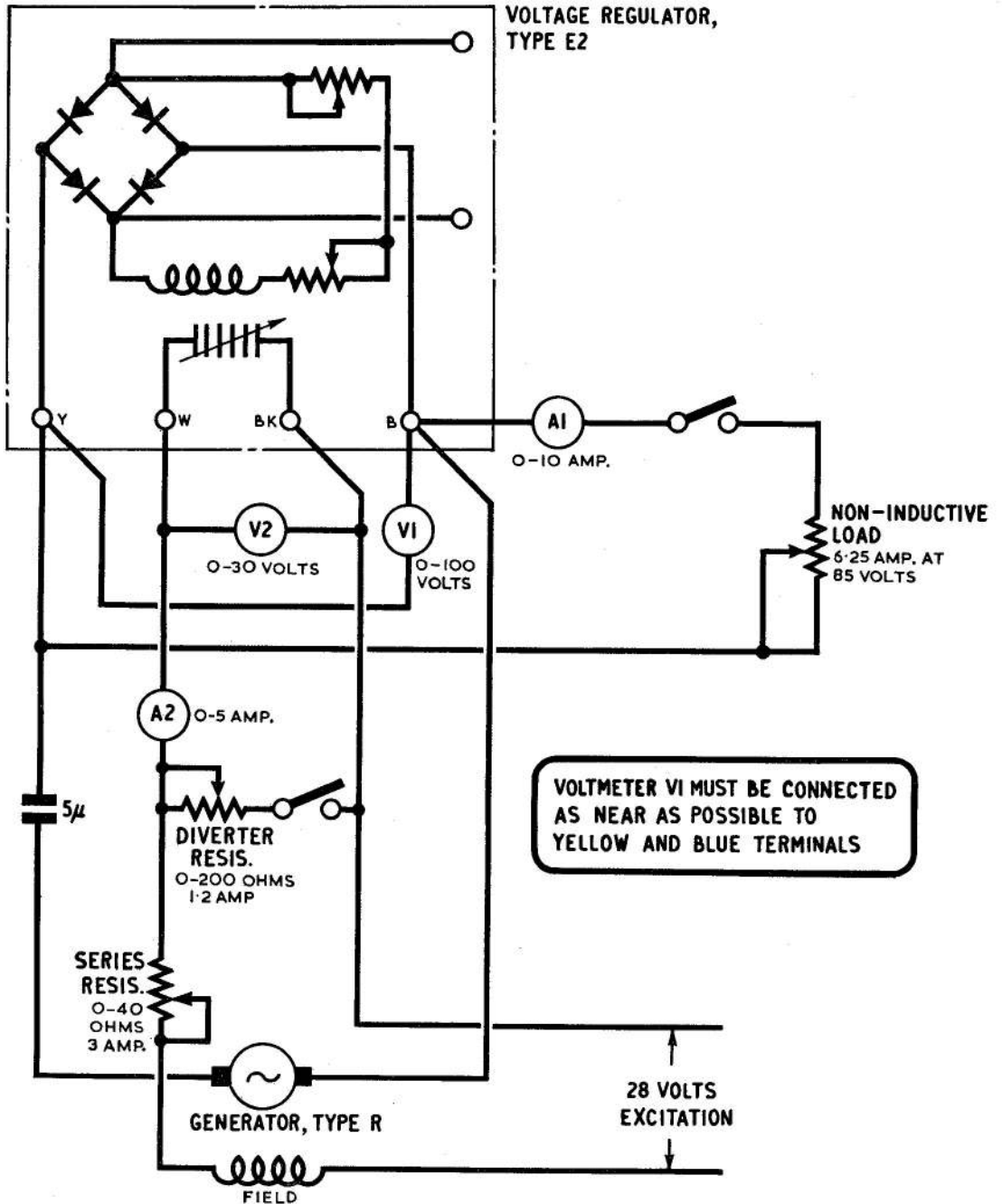

Fig. 2. Test circuit diagram

a load of 6.25 amp. Throughout these tests the line volts must not vary by more than 3 volts and must remain stable when the load is switched on and off at 6,000 r.p.m.

15. If the regulator is connected in a control panel, the same test must be applied. A dummy load of 6.25 amp. must be connected through a switch to the output plug.

(A.L.I, Aug. 57)

)

)

)

)

)

)

This file was downloaded
from the RTFM Library.
Link: www.scottbouch.com/rtfm

Please see site for usage terms,
and more aircraft documents.

