

## Chapter 2

# MOTOR GENERATOR, Type 13

### LIST OF CONTENTS

	Para.		Para.
Introduction ... ..	1	Testing ... ..	10
Description ... ..	2	Motor ... ..	11
Servicing ... ..	9	Generators—coupled to motor ... ..	14

### LIST OF ILLUSTRATIONS

		Fig.
Test circuit for motor generator, Type 13 ...	1	1

### LEADING PARTICULARS

<b>Motor generator, Type 13 (24-V)</b> ... ..	Stores Ref. 5U/4198
<b>Motor:—</b>	
Rotation (viewed from commutator end) ... ..	Anti-clockwise
Brush grade ... ..	CM6, HAM (Stores Ref. 5U/4695)
Brush spring pressure ... ..	16–20 oz.
Shunt field resistance (at 20 deg. C.) ... ..	11.2 ohms $\pm$ 10%
<b>Generators:—</b>	
Brush grade ... ..	CM6, HAM (Stores Ref. 5U/4695)
Brush spring pressure ... ..	16–20 oz.
Shunt field resistance (at 20 deg. C.) ... ..	11.4 ohms $\pm$ 10% on both generators

#### Introduction

1. Motor generator, Type 13, is an assembly of one motor coupled to two generators which provide the supply for the traverse and elevation motors on Bristol-type gun turrets. The motor generator is designed to be supplied with power at constant voltage from the aircraft battery, and to provide an output at a variable voltage.

#### DESCRIPTION

2. The unit comprises a motor and two generators arranged co-axially with one generator on either side of the motor; the motor and both generators are of the 4-pole compound-wound type. The common shaft on which the armatures of the motor and two generators are assembled is of tubular construction to reduce the weight. The core of the motor armature is mounted directly on to the shaft. The two generator armatures are built up on sleeves which fit over the driving shaft, each sleeve being secured to the shaft by a key, and by an end nut locked with a split pin.

3. The driving shaft is carried on two bearings, one on each side of the motor armature. The bearing at the commutator end is a roller bearing, having a plain inner race, while the bearing at the other end is of the ball type. This bearing arrangement allows for the slight end movement which may result from variations in the temperature of the components, and ensures that the bearings remain free under all normal operating conditions.

4. The bearings are fitted into end brackets spigoted into the motor yoke which carries the pole shoes and field coils. The end brackets and the motor yoke are assembled by four bolts which pass right through the motor and are secured by lock-nuts. The bracket at the commutator end of the motor is fitted with a plate carrying the brush gear assembly which comprises two brush boxes and the clock-type springs which hold the brushes against the commutator. On its opposite face, this same end bracket carries the brush gear for one generator, while the brush gear for the other generator is mounted on the second end bracket.

5. The yokes of the two generators are spigoted into the end brackets, and are secured by through-bolts, assembled in the same way as the motor yoke and end brackets. These generator through-bolts also hold in place the fitted end covers.

6. Inspection holes are provided in the yokes of the motor and generators, so that the brush gear and commutators can be examined without dismantling. Cover bands fit over the inspection holes and should always be replaced before the motor generator is put into operation.

7. Ventilation is provided by a fan mounted on the end of the armature shaft; air is drawn through the interior of the machine, entering through ducts in the end cover, and in the generator cover band remote from the fan.

8. Connections to the motor generator set are made by plug and socket assemblies, as follows:—

Both generators—Series field brush gear—  
Plug assembly (Stores Ref. 5X/4007)  
Shunt field—Plug assembly (Stores Ref. 5X/4001)  
Motor—Brush gear +ve and -ve—Plug assembly (Stores Ref. 5X/4025).

**SERVICING**

9. Instructions for the general servicing of rotary transformers will be found in A.P.4343, Vol. 1, Sect. 8.

**Testing**

10. Test details applying to this particular type of motor generator are as follows:—

*Motor*

11. No load test.—With motor at room temperature and no external load, adjust terminal voltage to 29V, and run for 2 minutes. Speed must not exceed 5,500 r.p.m., and current must not exceed 11 amp.

12. Load test.—With motor at room temperature, couple to a suitable brake. Adjust

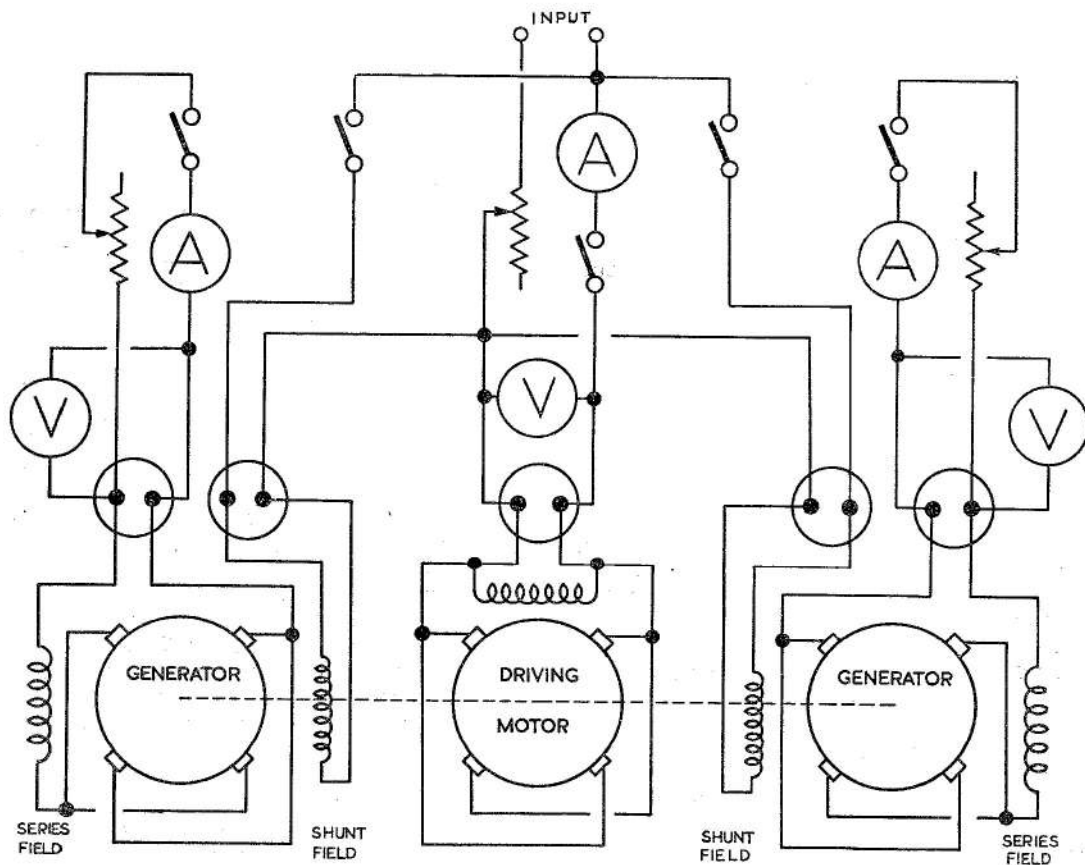

Fig. 1. Test circuit for motor generator, Type 13

**RESTRICTED**

terminal voltage to 27.5V and load to 3 lb. ft. Speed must not be less than 4,200 r.p.m., and current should not exceed 95 amp. During this test watch the commutation for detrimental sparking at the brushes.

**13.** Insulation test.—Insulation resistance between live parts and the frame must be not less than 1 megohm, checked with a 250V insulation tester immediately after the load test.

*Generators—coupled to motor*

**14.** Polarity of generators.—With the motor generator assembly wired according to the test circuit shown in fig. 1, connect the generator plugs in the following order:—field coil plug pin A to positive, and pin B to negative, supply. Run the motor generator set, and close the field switch. The polarity of the generator output must be plug pin No. 1 positive, and plug pin No. 2 negative. Open the field switch and repeat test for second generator.

**15.** Free running test.—Run the set with no external load, that is, with the generator shunt field switches and generator loading switches open. Adjust the terminal voltage of the motor to 28.7V. Speed of the motor must not exceed 5,000 r.p.m., and current must not exceed 14 amp.

**16.** Open circuit test.—Run the motor generator set with no external load. Close the shunt field switch of one of the generators, and adjust the motor volts to 24V. Voltage at the generator terminals must be not less than 45V. Motor generator speed must be not less than 4,500 r.p.m. and motor current must not exceed 17 amp. Open the shunt field coil switch and repeat the test for the second generator.

**17.** Load test.—After cooling to room temperature, run the motor generator set with no external load; close the loading and shunt field switches of one generator, and adjust the motor terminal volts to 22V. Adjust the generator current to 33 amp. by means of the loading resistance, and the generator terminal volts to 32V by means of the shunt field resistance. The motor current should not exceed 80 amp. and motor generator speed must be between 3,700 and 4,250 r.p.m. Open the shunt field coil and loading switches, and repeat the test for the second generator.

**18.** Insulation test.—The insulation resistance between the live parts and the frame must be not less than 1 megohm when checked with a 250V insulation resistance tester immediately after the above load test.

This file was downloaded  
from the RTFM Library.

Link: [www.scottbouch.com/rtfm](http://www.scottbouch.com/rtfm)

Please see site for usage terms,  
and more aircraft documents.

