

Chapter 3

ROTARY TRANSFORMER, TYPE 88X

LIST OF CONTENTS

| | Para. | | Para. |
|---------------------|-------|------------------|-------|
| Introduction | 1 | Servicing | 6 |
| Description | 2 | | |

LIST OF ILLUSTRATIONS

| | Fig. | | Fig. |
|---|------|------------------------|------|
| Rotary Transformer, Type 88X | 1 | Circuit diagram | 3 |
| Sectional view of rotary transformer | 2 | | |

LEADING PARTICULARS

| | |
|---|----------------------|
| Rotary transformer, Type 88X | Stores Ref. 5UB/5009 |
| Input— | |
| Armature | 15 volts d.c. |
| Field | 55 volts d.c. |
| Output | 38 volts d.c. |
| Field | 24 volts d.c. |
| Current— | |
| Motor armature | 1-25 amp. |
| Motor field (each winding) | 45 mA |
| Generator field | 16 mA |
| Rating | Continuous |
| Overall length (over shaft extensions) | 6 $\frac{7}{8}$ in. |
| Body diameter | 2 $\frac{3}{4}$ in. |
| Body length | 5 in. |
| Weight (complete machine) | 2 lb. 1 oz. |
| Weight (armature alone) | 9 oz. |
| Brush grades— | |
| Morgan, Crucible, Grade KCCM6 | Stores Ref. 5UB/6026 |
| Nobrac, Grade F.I.B. | Stores Ref. 5UB/6027 |

Introduction

1. The rotary transformer, Type 88X (fig. 1) is used in conjunction with automatic computing devices. With an input of 15 volts d.c. and at a speed of 6,000 r.p.m., it will deliver an output of 38 volts d.c. \pm 10 per cent; the voltage output is directly proportional to the speed within 2 per cent.

DESCRIPTION

2. The rotary transformer, Type 88X, incorporates a d.c. motor driving a d.c. generator. As can be seen in the sectional drawing in fig. 2, the two armatures are mounted on a common shaft, and the motor and generator fields are separately excited. The motor field system comprises two windings, arranged so that one winding is used for clockwise rotation and the other winding for anti-clockwise rotation. A circuit diagram is given in fig. 3.

3. All connections to the machine are taken through holes in the yoke by screened cables. The red and black leads for the 15-volt d.c. input are covered by one length of metal-braided sleeving, and the yellow, green, white and brown leads for the 55-volt d.c. motor excitation by another length, both secured to the frame by two arms of an earthing clip. There is a similar arrangement at the generator end, where the 38-volt d.c. output leads and the 24-volt d.c. generator excitation leads are similarly screened and bonded.

4. Access to the brush gear at the motor and generator ends is gained by removal of the perforated inspection covers, two at each end. The brushes themselves are held in boxes, brush pressure being maintained by springs held in position by a brush cap. When the brush box is fitted, it is pushed down until the flange on the box seats in the recess in the

(A.L.1, Sep. 57)

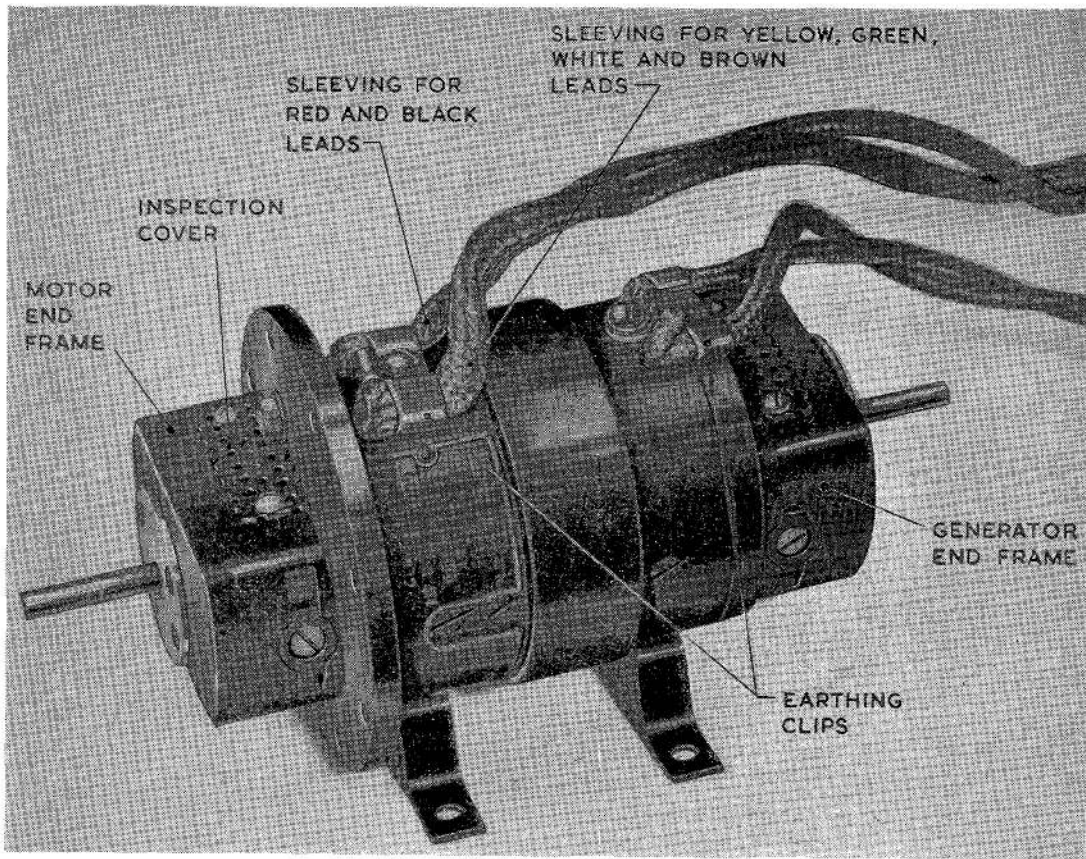

Fig. 1. Rotary transformer, Type 88X

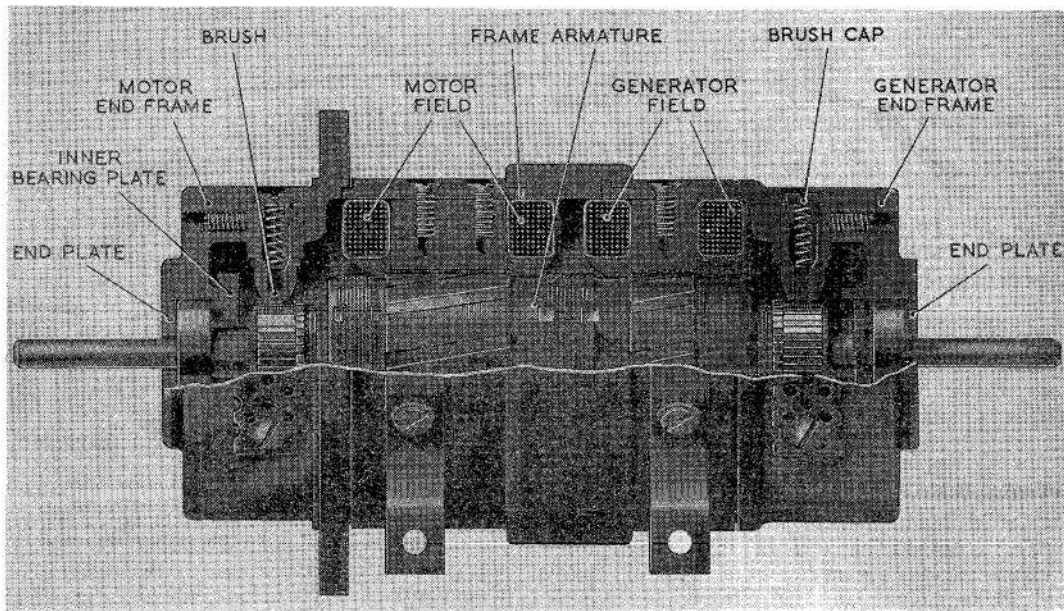

Fig. 2. Sectional view of rotary transformer

RESTRICTED

end frame. It is located radially by the shape of the recess, and is secured by a grub screw inserted from the end face of the machine.

5. The main shaft runs in bearings mounted in the end frames and lubricated with grease XG-290 (Stores Ref. 34B/9105057). At the motor end, the bearing is locked positively between two bearing retaining plates. At the generator end, the bearing is allowed freedom to move axially in order to compensate for slight expansion due to temperature. The securing screws of each end plate are locked with varnish; the bearings should not require re-lubrication between major repair periods.

SERVICING

6. General servicing instructions for this type of machine are given in A.P.4343,

Vol. 1, Sect. 8. The only servicing that should be necessary is attention to the brush gear and inspection for general security of connections. Details of the correct brush grades are given under Leading Particulars.

Note . . .

Two brush grades are quoted under Leading Particulars and either may be used; it is important, however, that the brush grades should never be mixed, only one grade being used at one time.

7. The rotary transformer should be run to ensure that with the correct field excitation and an input of 15 volts d.c., the output is 38 volts d.c. \pm 10 per cent. at a speed of 6,000 r.p.m.; at other speeds, the voltage output should be linear with the speed.

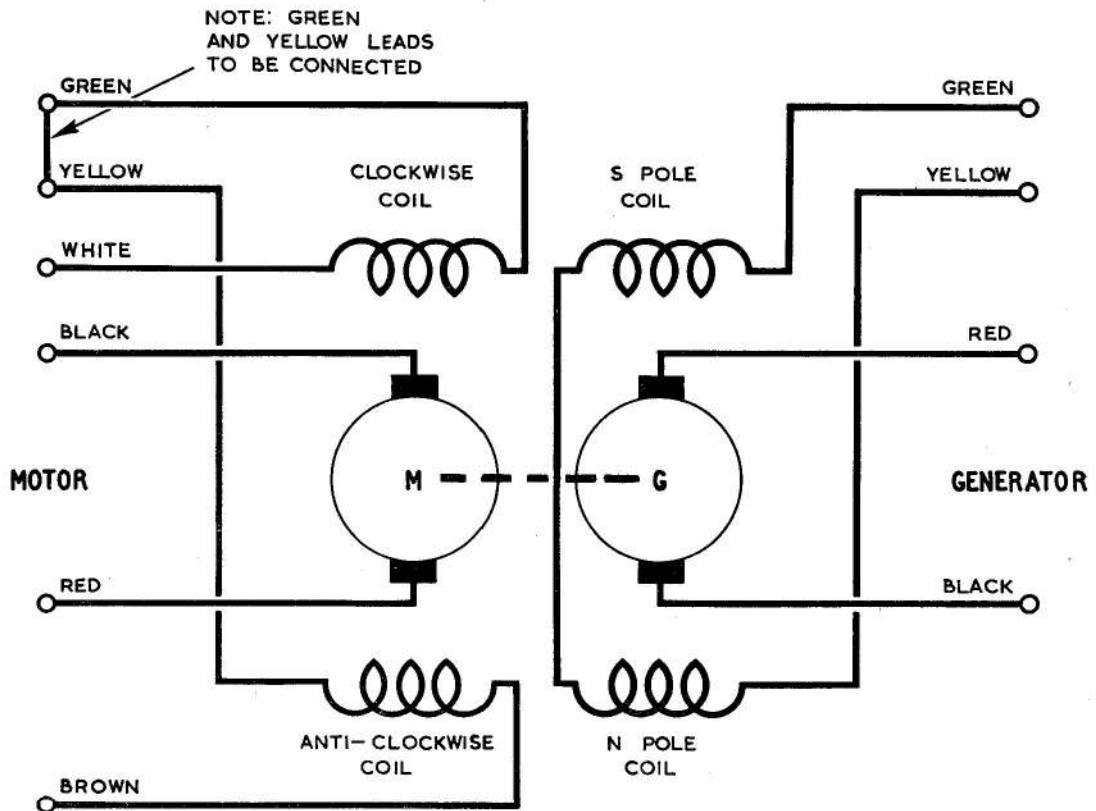

Fig. 3. Circuit diagram

This file was downloaded
from the RTFM Library.

Link: www.scottbouch.com/rtfm

Please see site for usage terms,
and more aircraft documents.

