

Chapter I

ROTARY INVERTER, TYPE RC2

LIST OF CONTENTS

	Para.		Para.
Introduction	1	Servicing	9
Description	2		
Installation	8	Testing	11

LIST OF ILLUSTRATIONS

	Fig.		Fig.
Rotary inverter, Type RC2	1	Sectional drawing	3
Schematic diagram of field windings	2	Diagram of connections	4

LEADING PARTICULARS

Rotary inverter, Type RC2	Ref. No. 5UB/2399
Input	24V d.c., 40 amp.
Output	80V a.c., 6.25 amp. at unity power factor
Frequency	1,200 c/s at 5,140 r.p.m.
Brush grade	E.G.O. (H.A.M.), (Ref. No. 5UA/3251)
Brush spring pressure	Not less than 11 oz.
Regulation	Control panel, Type 9A
Winding resistance values:—	
Armature	0.032 ohm
A.C. winding (D1-D2)	0.356 ohm
Field windings:—	
Compensating winding (KK-K)	0.022 ohm
Bucking winding (KK-X3)	6.17 ohms
Boost and main (KK-A) Link con. A	12.02 ohms
Link con. B	11.51 ohms
Link con. C	11.10 ohms
Link con. D	10.78 ohms
Dimensions	12 $\frac{5}{16}$ in. x 6 $\frac{3}{8}$ in.
Weight	30 lb.

RESTRICTED

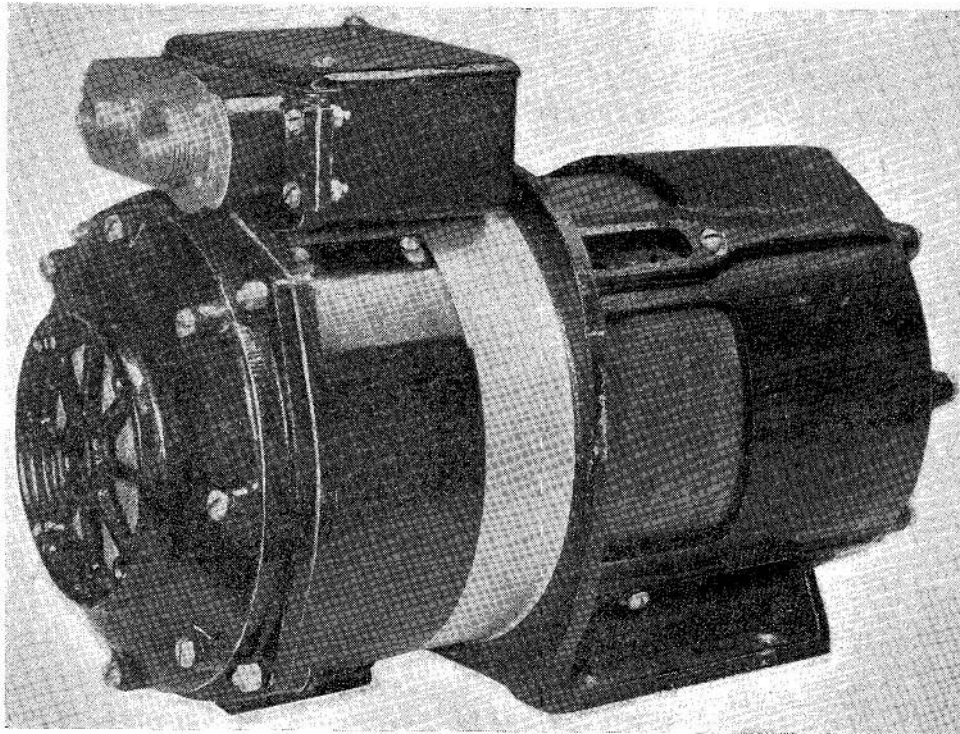

Fig. 1. Rotary inverter, Type RC2

Introduction

1. This rotary inverter has been designed to provide a high frequency a.c. supply of 80 volts for radio, on aircraft where it is not possible to use an engine-driven generator for this purpose. A common stator and rotor core construction is used for both a.c. and d.c. windings. The machine gives an a.c. output of 6.25 amp. at 80 volts at unity power factor, absorbing about 40 amp. at 24 volts. The frequency of the a.c. output is 1,200 c/s at a rotor speed of 5,140 r.p.m.

DESCRIPTION

2. The machine is of the heteropolar type and has four exciting coils connected in parallel, in addition to a series compensating winding, four boost windings and four bucking windings. The a.c. winding is wound in slots in the pole faces, the alternating e.m.f. being obtained by the variations of flux which are produced by the passage of the armature teeth past the slotted pole face. The d.c. motor armature windings connected to the commutator segments are carried in slots between the rotor teeth.

3. The compensating winding, which is also a series compounding winding, prevents flux distortion in the pole face, due to the d.c. flowing in the armature. Short-circuited damping windings are provided on each pole. A schematic diagram showing the arrangement of the various windings is given in fig. 2, and a diagram of connections in fig. 4.

4. The mechanical construction of the rotary inverter is shown in fig. 1, and a sectional drawing appears in fig. 3. The main frame is a tubular casting carrying the field laminations and extended to support the terminal box which is mounted at the commutator end. The field assembly consists of stampings slotted to carry the various windings including that carrying the a.c. output. The ends of the windings are brought out to a terminal block mounted in the terminal box on the top of the housing.

5. The bearings are of the ball type, the commutator end bearing being clamped

RESTRICTED

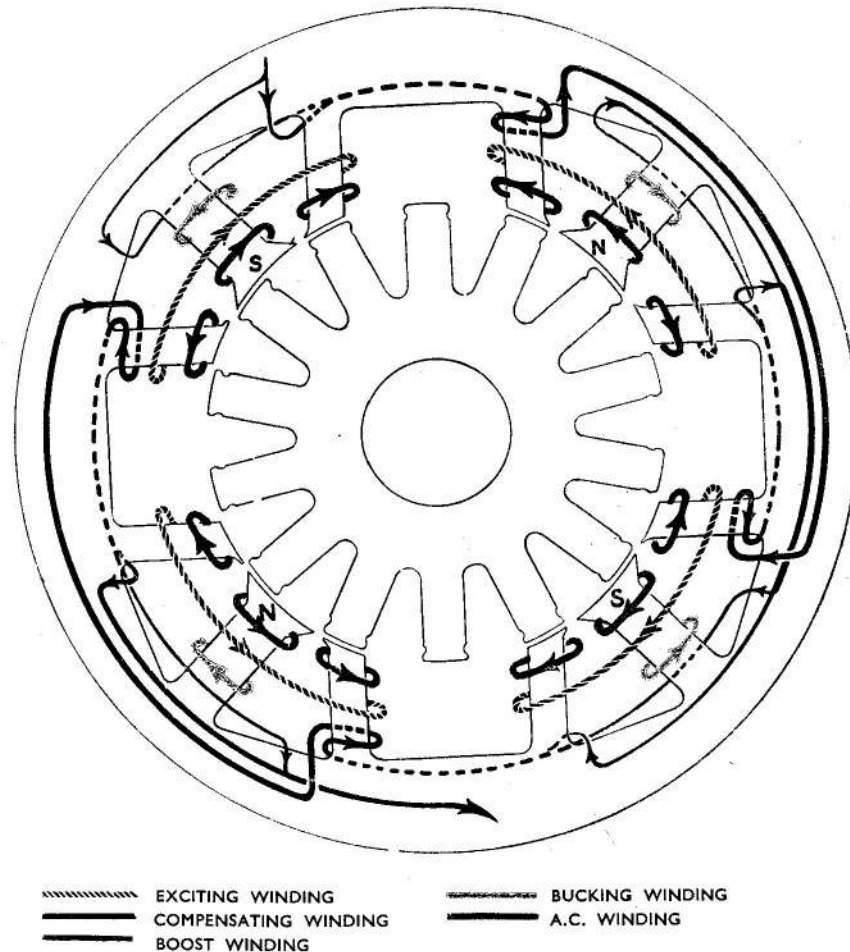

Fig. 2. Schematic diagram of field windings

between the outer and inner caps by four bolts, and the driving end bearing being spring-loaded by a compression spring which lies in a channel in the inner side of the fan end bearing cap. The inner race of the commutator end bearing is secured to the armature by a nut locked by a special washer.

6. The brush rocker is secured to the end frame by screws which project through slots in the rocker, thus allowing for adjustment. Each of the four brush boxes is secured to the rocker by a fixing screw. A terminal screw carries the interconnections between diagonally opposite brushes; connection is also made to the compensating winding and terminal block through two isolated terminals on the edge of the rocker. Clock type coil

springs are used to hold the brushes in position.

7. Opposite the commutator end the shaft is extended to carry the fan which is keyed to it, and an end cover is secured by screws to the main frame to guard the fan. The machine is provided with feet to facilitate mounting.

INSTALLATION

8. The rotary inverter, Type RC2, is operated in conjunction with a control panel, Type 9A. The use of a starting relay in the control panel enables the inverter to be controlled from a remote position. A complete diagram of connections will be found in Sect. 7, Chap. 9.

(A.L.1, Sep. 57)

F.S./2

RESTRICTED

B (AL1)

RESTRICTED

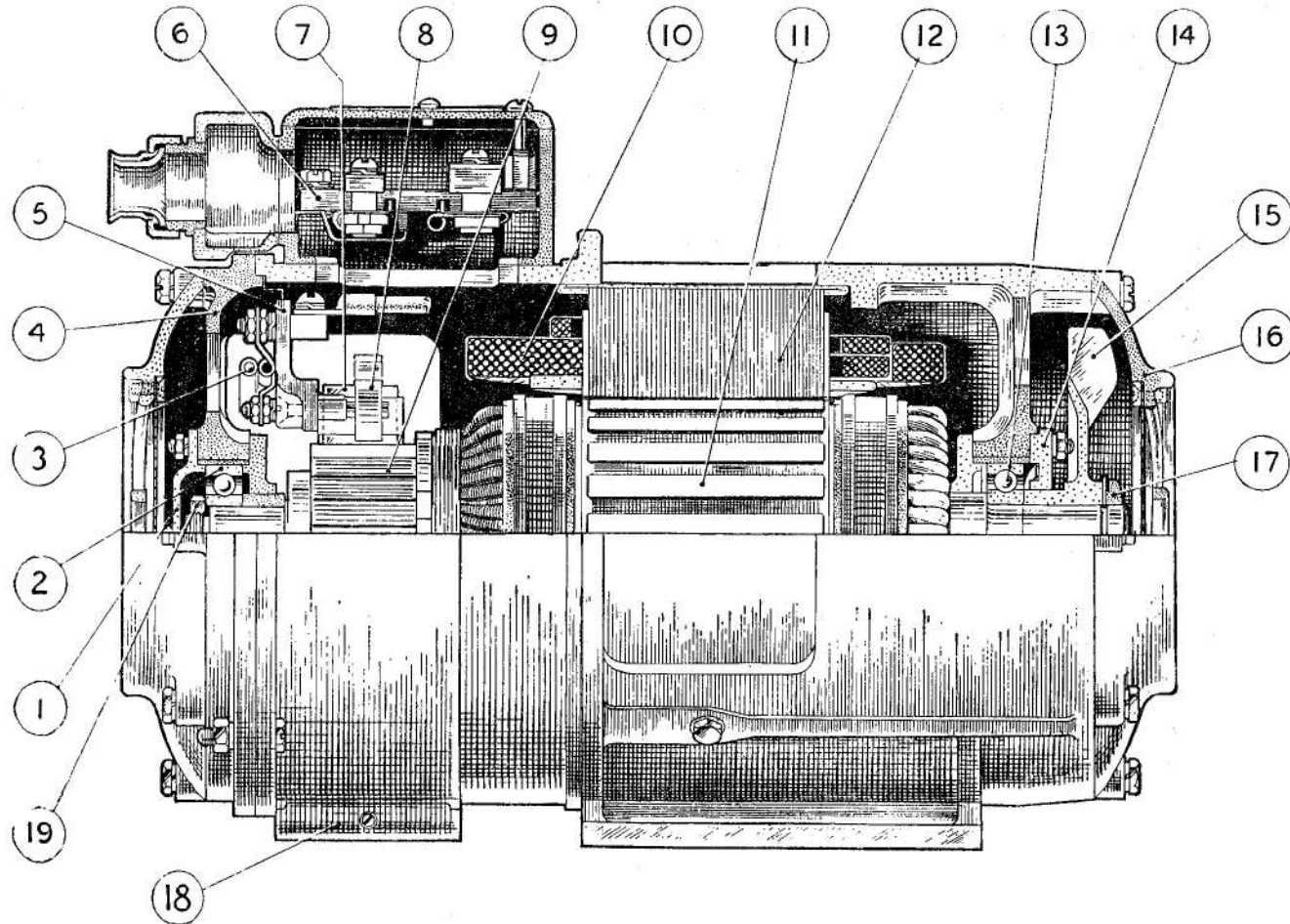

- | | | | | |
|-------------------------|------------------|---------------|------------------------|--------------------------|
| 1 OUTER BEARING CAP | 5 BRUSH ROCKER | 9 COMMUTATOR | 13 BALL BEARING | 17 FAN NUT |
| 2 BALL BEARING | 6 TERMINAL BLOCK | 10 FIELD COIL | 14 OUTER BEARING PLATE | 18 COMMUTATOR COVER BAND |
| 3 BRUSH INTERCONNECTION | 7 BRUSH | 11 ARMATURE | 15 FAN | 19 BEARING NUT |
| 4 COMMUTATOR END FRAME | 8 BRUSH SPRING | 12 FIELD POLE | 16 END COVER | |

Fig. 3. Sectional drawing

SERVICING

9. Bearings may be greased after removing the covers at each end. The fan should be withdrawn from the shaft to which it is keyed after undoing the bearing nut and locking washer. The outer bearing plates, which are secured by nuts, can now be removed, giving access to the bearings for lubrication. Take care not to damage or lose the compression washer in the inner side of the fan end bearing cap. Grease XG-275 (Stores Ref. 34B/9100512) should be employed.

10. Brushes should be renewed when they wear down to a length of $\frac{3}{8}$ in. on the centre line. This can be done after removing the brush gear cover band which is detachable in two halves. When tightening the cover band during re-assembly care must be taken to see that the holes in the band are correctly located on the pins in the frame. Details of brush grade and correct spring pressure are given under Leading Particulars.

Testing

11. It will normally be sufficient to run the machine on full load and check that:—

- (1) The brushes are bedding correctly and that there is no undue sparking.
- (2) The output voltage is 80 r.m.s.

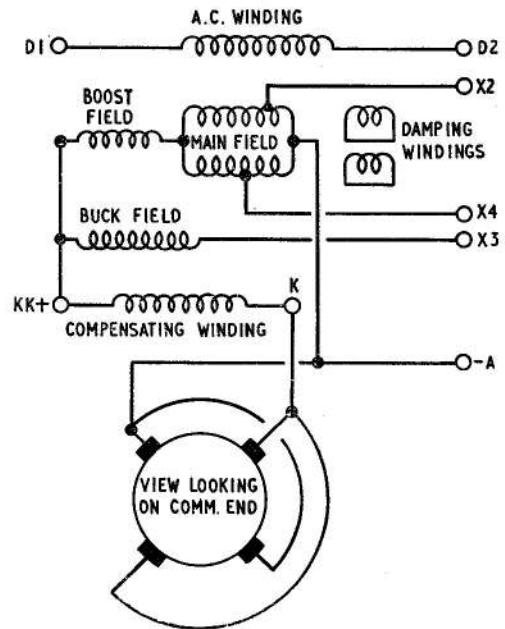

Fig. 4. Diagram of connections

12. Approximate resistance values of the field and armature windings are given in Leading Particulars to facilitate fault finding when dealing with defective inverters.

This file was downloaded
from the RTFM Library.

Link: www.scottbouch.com/rtfm

Please see site for usage terms,
and more aircraft documents.

