

See AP 113D-0106-16  
HFLD

## Chapter 10 ROTARY INVERTERS, ROTAX, S3100 SERIES

### LIST OF CONTENTS

	Para.		Para.
<i>Introduction</i> ... ..	1	<i>Removal of a.c. brushgear assembly</i>	21
<b>Description</b> ... ..	2	<i>Removal of armature and rotor assembly</i> ... ..	22
<i>D.C. housing</i> ... ..	3	<i>Examination</i> ... ..	24
<i>Yoke, poleshoes and field coil assembly</i> ... ..	5	<i>A.C. and D.C. brushes</i> ... ..	25
<i>A.C. housing</i> ... ..	6	<i>A.C. and D.C. brush springs</i> ... ..	26
<i>Suppressor unit</i> ... ..	7	<b>Assembly</b> ... ..	27
<i>Mounting</i> ... ..	8	<i>Re-fitting the armature and rotor assembly</i> ... ..	28
<b>Operation</b> ... ..	9	<i>A.C. brushgear assembly</i> ... ..	29
<b>Installation</b> ... ..	12	<b>Testing</b> ... ..	34
<b>Servicing</b> ... ..	16	<i>Brush bedding</i> ... ..	35
<i>Dismantling</i> ... ..	17		

### LIST OF ILLUSTRATIONS

	Fig.		Fig.
<i>Typical S3100 series inverter</i> ... ..	1	<i>Voltage correction channel</i> ... ..	3
<i>Sectional view of typical inverter</i> ... ..	2	<i>Frequency correction channel</i> ... ..	4

### LIST OF APPENDICES

	App.		App.
<i>Standard serviceability test for rotary inverters, Rotax, S3100 series</i> ... ..	A	<i>Rotary inverter, Type 103B (Rotax S3109)</i> ... ..	3
<i>Rotary inverter, Type 103 (Rotax S3101)</i> ... ..	1	<i>Rotary inverter, Type 103C (Rotax S3110)</i> ... ..	4
<i>Rotary inverter, Type 103A (Rotax S3106/1)</i> ... ..	2		

#### **Introduction**

1. Rotary inverters in the S3100 series have been designed to provide, in conjunction with a control panel or panels, certain aircraft instruments and equipment with a 115-volt, 3-phase, 400 c/s supply at controlled voltage and frequency. Basically, all the inverters are similar in general appearance and construction, and differ mainly in the value of

input voltage and type of d.c. field system and in the associated control panel(s). In Appendices to this chapter, details are given of machines with a 25 to 28-volt d.c. input; other machines in the series are designed for an input of 100 to 116-volt d.c., and details of such inverters will be found in Appendices to Sect. 17, Chap. 2 of this publication.

**RESTRICTED**

## DESCRIPTION

2. A typical inverter in the series is illustrated in fig. 1 and 2. Electrically, the machine consists of a d.c. compound-wound motor driving a 3-phase a.c. generator, the mechanical coupling being achieved by mounting the armature and rotor on a common shaft. The inverter comprises four main assemblies, i.e., the d.c. housing, yoke poleshoes and field coils assembly, a.c. housing and suppressor unit.

### D.C. housing

3. Contained within the d.c. housing is the d.c. brushgear, roller bearing and fan assembly. The brushgear assembly is secured by four screws passing through slots in the housing; these slots allow for positioning of the brushgear relative to the Geometrical Neutral Position. A clamp plate secures the outer race of the roller bearing, through the centre bore of which the armature and rotor shaft extends to support the fan assembly.

4. Secured to the end of the housing is the air inlet spout or end screen, depending upon whether a blast or free air inlet is required. Normally, blast air is required when the air-

craft flies above 35,000 ft. Access to the brushgear for inspection purposes is provided by a removable window strap assembly.

### Note . . .

*In machines fitted with a piped air inlet, drain holes have been introduced by modification action to allow accumulated moisture to drain away. The housings have also been treated with a protective resin finish as an anti-corrosive measure.*

### Yoke, poleholes and field coil assembly

5. The yoke, poleshoes and field coil assembly is positioned and clamped between the a.c. and d.c. housings by four bolts passing through flanges in the respective housings. Accurate alignment between the sections is ensured by the provision of spigoted faces on the yoke.

### A.C. housing

6. Situated in the a.c. housing are the stator assembly, ball bearing, a.c. brushgear, and fan assembly. The stator is secured in the correct position relative to the rotor by a clamp bolt through two holes in the upper part of the housing and locating in a groove machined in the stator frame. The a.c. brushgear is mounted directly to the housing

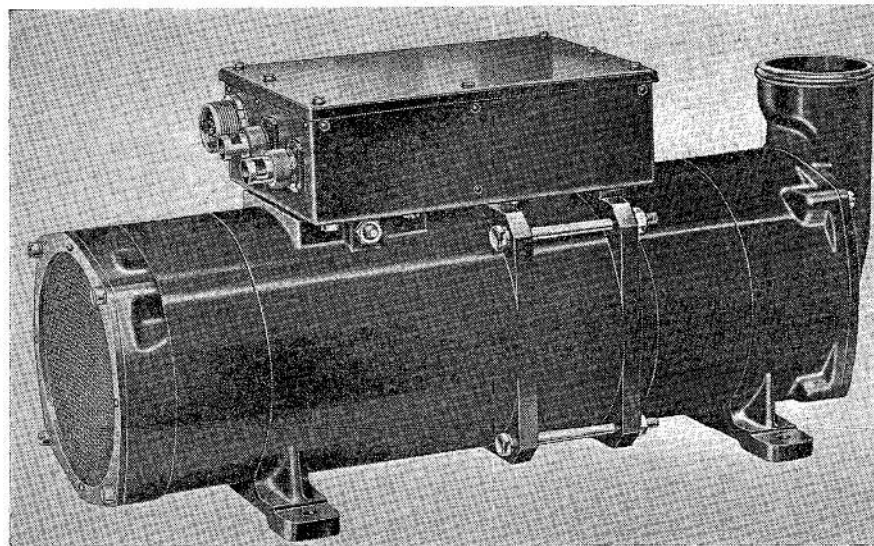
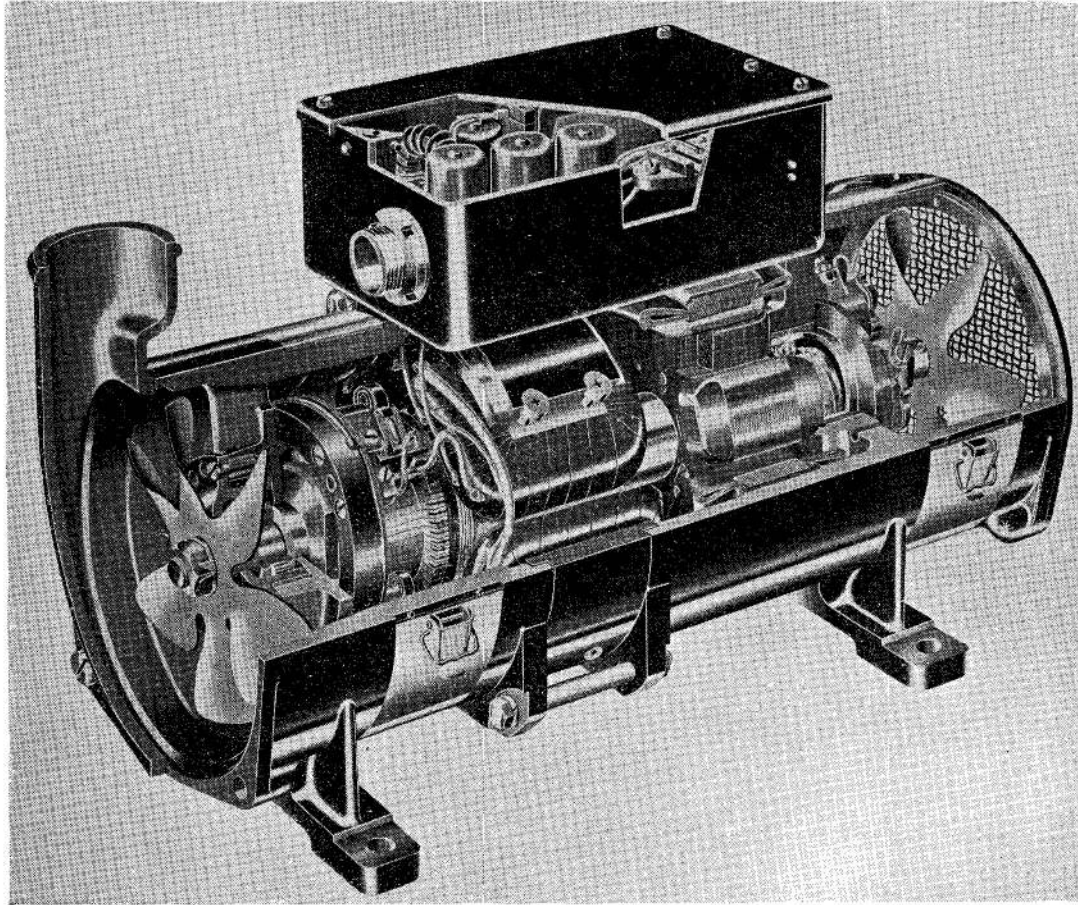

Fig. 1. Typical S3100 series inverter

RESTRICTED



**Fig. 2. Sectional view of typical inverter**

adjacent to the bearing housing and is suitably spigoted to ensure correct alignment and also to clamp the outer race of the bearing. The armature and rotor shaft is extended to carry the two slip-rings and the fan assembly. A screen is secured directly to the end of the housing in order to provide a free air outlet. Access to the a.c. brushgear is facilitated by a second removable strap assembly.

#### **Suppressor unit**

7. The suppressor unit is mounted directly to the top of the inverter and is secured in position by four screws. This unit contains the components which comprise the suppression circuit, together with terminal blocks for the internal a.c. and d.c. connec-

tions and also for the d.c. input connections. Cables for the latter enter the suppressor box via cable glands. The a.c. output from the inverter is taken via a 3-pole Mk. 4 miniature plug, and interconnection between the inverter and control panel is effected via a 12-pole miniature plug. All components within the suppressor box are screened electrically and protected mechanically by a cover secured to the top of the box by seven screws.

#### **Mounting**

8. Mounting of the inverter in the aircraft is achieved by four mounting feet which are cast integrally with the a.c. and d.c. housings, each foot having a hole 0.312 in. in diameter for the mounting bolt.

**RESTRICTED**

## OPERATION

9. The principle of operation is that of a 4-pole motor, driving a 6-pole, 3-phase a.c. generator. Direct current is applied to both the motor section (causing the armature/rotor shaft to rotate in a clockwise direction viewed from the commutator end) and to the rotor via the slip-rings. The current supplied to the rotor windings causes a magnetic flux around the six laminated poles of the rotor, which, as it rotates, induces an e.m.f. in each of the stator windings in turn, phase sequence relative to the 3-pole plug being A-B-C.

10. These inverters are normally used in conjunction with a control panel, such as Type 15 (Rotax U1502/2), as described in Book 2, Sect. 7 of this publication. The control panel maintains the a.c. output voltage and frequency at  $115V \pm 2$  per cent and  $400 \text{ c/s} \pm 2$  per cent respectively, under varying conditions of load and temperature. As the performance of the inverter and its associated panel is closely related, a brief description of a typical installation is given in the following paragraph.

11. Fig. 3 and 4 are schematic layouts of the voltage and frequency control channels of a typical installation. Referring to these blocks, the output voltage and frequency variations are first determined by the voltage "error" and frequency "error" detectors, causing out-of-balance effects in the respective tuned circuits. When a load is applied to the output, both the voltage and frequency tend to fall. The out-of-balance conditions are suitably amplified magnetically through various stages, and corrective currents are passed to (a) the control winding of the d.c. field, resulting in a speed increase to restore the frequency, and (b) to the rotor via the slip-rings, causing a stronger flux which results in a restoration of the voltage. The out-of-balance effect in the error detectors is also produced when the load of the output is reduced, but in this instance the corrective currents to the motor and slip-rings are such

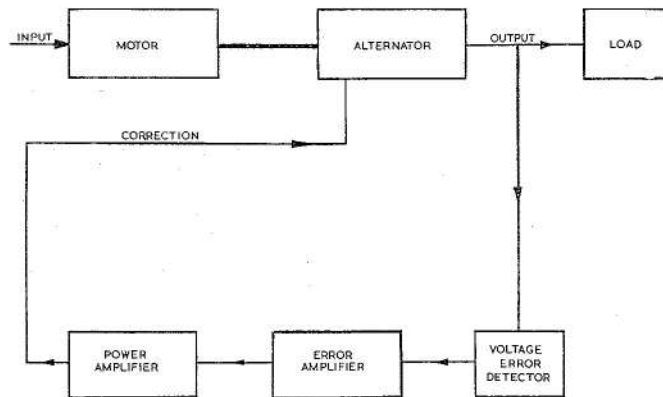

Fig. 3. Voltage correction channel

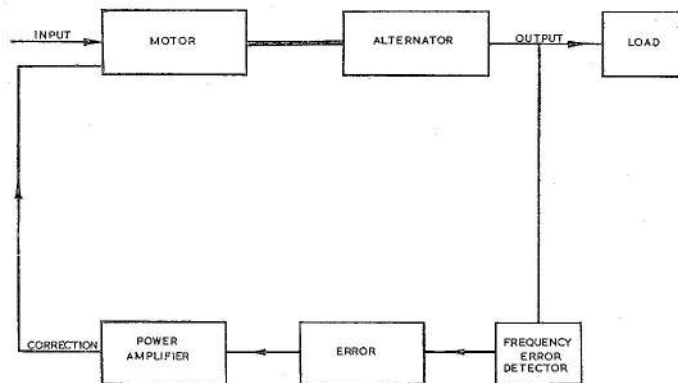

Fig. 4. Frequency correction channel

that they tend to cause, respectively, a speed and voltage decrease, which result in corresponding correction of the output frequency and voltage.

## INSTALLATION

12. Information on particular installations of these inverters will be found in the relevant Aircraft Handbook.

13. The machine may be mounted in any position to suit the requirements of the particular aircraft installation; it is then secured by suitable bolts through the holes in the mounting feet.

14. If an air inlet is fitted to the inverter, suitable arrangements must be made for a blast air supply. Where an inverter is fan-cooled only, provision should be made for an adequate circulation of free air through and

**RESTRICTED**

around the unit. The blast air requirements are as follows:—

Air temperature (deg. C)	Cooling air requirements (lb/min.)
-30	0.95
-10	1.15
+10	1.55
+30	2.10
+50	2.90

15. For interconnection between the inverter and its associated control panel(s), screened cables fitted with plugs and sockets are used. All cable runs, including the input d.c. cable, should be kept as short as possible so that weight and volt drop are reduced to a minimum.

### SERVICING

16. Servicing on the aircraft will normally be confined to examination for freedom from mechanical damage and corrosion. Electrical connections and the inverter mounting should be checked for security. If the serviceability of the inverter is suspect it should be tested as described in the Standard Serviceability Test, Appendix A of this chapter. The inverter should be serviced as described in the following paragraphs, with reference to the relevant Servicing Schedule.

#### Dismantling

17. Release the toggle clips on each of the window strap assemblies and remove the assemblies. Remove the screw securing the suppressor box cover and lift the cover from the suppressor box. Remove the two bolts holding the suppressor box to the inverter at the d.c. end, in preparation for withdrawing the d.c. end housing.

18. Disconnect the electrical leads connecting to the d.c. and a.c. brushgear. Remove the brushes and identify them with their boxes.

19. Remove the screws securing the end screen assembly at the a.c. end, and the air inlet spout or the end screen assembly at the

d.c. end. Lift the assemblies from the inverter.

20. Bend back the tab washer and unscrew the a.c. cooling fan securing nut. Remove the nut, tab washer and fan from the armature and rotor shaft.

#### Note . . .

*During the operations of removing the a.c. cooling fan securing nut para. 5 and the armature rotor assembly securing nut para. 7 it is advisable to hold the d.c. end securing nut with a spanner to prevent the central shaft from turning.*

#### Removal of the a.c. brushgear assembly

21. Mark the position of the a.c. brushgear relative to the housing prior to removal. Unscrew the four securing screws and lift the brushgear assembly from the housing.

#### Removal of the armature and rotor assembly

22. Bend back the tab washer and unscrew the nut securing the armature and rotor assembly at the a.c. end. Remove the four bolts with their clamp nuts, plain washers and tab washers that secure the d.c. housing assembly to the a.c. housing assembly. Gently ease the d.c. housing assembly complete with the d.c. brushgear and the armature and rotor assembly, away from the a.c. housing assembly, ensuring that the electrical leads do not become trapped or damaged and that internally positioned components do not foul each other when the a.c. end of the armature and rotor shaft becomes free from the a.c. end ball bearing.

23. Bend back the tabwasher, at the d.c. end of the commutator and rotor shaft, and remove the locking nut and the cooling fan from the shaft. Withdraw the shaft assembly from the d.c. end ball bearing and end housing.

#### Examination

24. All components of the dismantled inverter must be examined for mechanical and electrical defects in conjunction with A.P. 4343, Vol. 1, Sect. 8, Chap. 2. The procedures for skimming the armature, bedding the brushes and fitting the bearings may also be found in A.P. 4343 and the relevant Air Diagrams.

**RESTRICTED**

### **A.C. and D.C. brushes**

25. The brushes must be examined and renewed if pitted, chipped or burnt, or if the brush length measured on the long face is less than the minimum brush length given in the leading particulars of the relevant Appendix to this chapter, or may reach the minimum permissible length before the next scheduled servicing.

### **A.C. and D.C. brush springs**

26. Using a suitable spring balance measure the tension of the a.c. and d.c. brush springs to ensure that they are in accordance with the spring tension requirements given in the leading particulars of the relevant Appendix to this Chapter. The tension of the spring is measured when the trigger is level with top of the brush box. If the reading is not satisfactory, adjust the position of the spring at its support post. Should the required reading not be obtained without overwinding, renew the brush spring.

### **ASSEMBLY**

27. Fit the armature and rotor assembly to the d.c. end ball bearing and end housing. Fit the d.c. cooling fan to the shaft and secure with the tab washer and lock nut.

### **Refitting the armature and rotor assembly**

28. Ease the armature and rotor shaft a.c. end into the bore of the ball bearing ensuring that the electrical leads do not become trapped or damaged and that internal components do not foul each other. Correctly position the mating faces of the a.c. and d.c. housing assemblies and fit the four securing bolts with their associated nuts and washers. Fit the tab washer and locking nut to the a.c. end of the central shaft. Tighten the nut and bend back the washer tab.

### **A.C. brushgear assembly**

29. Position the a.c. brushgear assembly in the a.c. housing, with the marks made at

dismantling coinciding, and secure with the four fixing screws and lock washers.

30. Fit the a.c. fan to the armature and rotor shaft and secure with the tab washer and locking nut.

31. Position and secure the a.c. end screen assembly and the d.c. air inlet spout or end screen assembly.

32. Fit the brushes into their brush boxes and re-connect the electrical leads to the d.c. and a.c. brushgear assemblies.

33. Fit the two bolts securing the d.c. end of the suppressor box to the a.c. housing assembly. Re-fit the suppressor box cover and secure with four fixing screws and shake-proof washers. Fit the two window strap assemblies and secure with the toggle clips.

### **TESTING**

34. After re-assembly test the inverter as given in the Standard Serviceability Test Appendix A to this Chapter.

### **Brush bedding**

35. Make the following connections to a 28V d.c. supply:—

- (1) Pin B (12 pin plug) to supply positive through an 0 to 1 amp ammeter and variable resistor.
- (2) Pin C (12 pin plug) to supply negative.
- (3) Inverter positive terminal supply positive.
- (4) Inverter negative to terminal supply negative.

Set the current through pin B at approximately 0.4 amp. and run the inverter on no load until the brushes are bedded over their full axial width and over 80 per cent of the contact area.

**RESTRICTED**

## Appendix A

### STANDARD SERVICEABILITY TEST FOR ROTARY INVERTERS, ROTAX, S3100 SERIES

#### Introduction

1. The following tests may be applied to the machine before it is put into service, or at any time when its serviceability is suspect.

#### Test equipment

2. The following test equipment is required:—

- (1) Insulation resistance tester, Type C (Ref. No. 5G/152).
- (2) Inverter tester (Ref. No. 5G/564).
- (3) Variable reactive load (Ref. No. 5G/3273).
- (4) Control panel, Type 15 or 15B (as appropriate).
- (5) Starting switch, Type 1A, No. 5 (Rotax U2005/1).

#### Testing

##### Insulation resistance test

3. The insulation resistance, measured with a 250-volt insulation resistance tester between the following points, should not be less than 50,000 ohms.

##### Note . . .

*All suppression equipment should first be disconnected from the a.c. and d.c. sides.*

- (1) *Between the positive brush box and frame.*
- (2) *Between the stator and frame (all d.c. live parts bonded to frame).*

##### Performance test

4. The following external connections should be made before the machine is run.

- (1) *Control winding circuit.* Using an auxiliary d.c. supply (10-40V), connect positive to pin B (12-pole plug), and connect the negative through a suitable

ammeter and variable resistor to pin C (12-pole plug).

##### Note . . .

*With inverters which have a separate shunt field terminal S, this terminal must be connected to the positive of the input supply, or, when a starter is used, to the supply side of the starter.*

- (2) *Rotor circuit.* Connect a suitable ammeter and variable resistor between pins A and D (12-pole plug).

##### Note . . .

*When starting up, switch on the auxiliary supply first, and set the current to 0.4 amp. When shutting down, switch off the auxiliary supply last.*

5. Run the machine on full load (115V, 750W, 0.8 p.f. lag) at an input of 25 volts, and a speed of 8000 r.p.m. (or frequency of 400 c/s). At the end of this run,

- (1) The input current must not exceed 59 amp.
- (2) The control current must not be less than 0.150 amp.
- (3) The rotor current must be 2.2-2.55 amp.

6. Immediately after the above test, run the machine on no load at an input of 28 volts, with an output voltage of 115 volts and a speed of 8000 r.p.m.

Then:—

- (1) The input current must not be greater than 21 amp.
- (2) The control current must not exceed 0.380 amp.
- (3) The rotor current must be 1.4-1.75 amp.

RESTRICTED

If the control current is outside the specified limits in either of the tests, it may be adjusted by means of the shunt field ballast resistance. An increase in shunt resistance increases the control current, and a decrease in shunt resistance reduces the control current.

*Functioning test*

7. The inverter should be started and run in conjunction with a Type 15 or 15B control panel (as appropriate), and a starting switch, Type 1A, No. 5 (Rotax U2005/1). For this test the following procedure should be adopted.

- (1) Re-make the suppression box connections, and across the output of the inverter connect a preset load such that when the output is 115V, 400 c/s, the inverter will deliver 750W, 0.8 p.f. lag.
- (2) Adjust the open-circuit supply voltage to 26 volts and switch on the inverter.

**Note . . .**

*The open-circuit supply voltage may be increased if the regulation of the supply is poor.*

- (3) Whilst the inverter is running, re-adjust the supply voltage until the input terminal voltage is 25 volts. The machine should be allowed to run under these conditions for a period of 10 minutes, at the end of which time the output voltage and frequency should be recorded.
  - (4) Immediately after recording the above values, switch off the load on the output of the machine and increase the input terminal voltage to 28 volts. Record the output voltage and frequency.
8. In each instance, the output line voltage must be between 113 and 117 volts, and the output frequency between 398 and 402 c/s. The unbalance in the line voltages between any pair of lines must not exceed 2 volts.

**RESTRICTED**

## Appendix 1

### ROTARY INVERTER, TYPE 103 (ROTAX S3101)

#### LEADING PARTICULARS

<b>Inverter, Type 103</b>	...	...	...	...	Ref. No. 5UB/5758
<i>Input voltage</i>	...	...	...	...	25 to 28 volts d.c.
<i>Output</i>	...	115 volts, 400 c/s, 3-phase a.c.	750W, 4.7 amp. at 0.9 p.f.	...	(leading) to 0.8 p.f. (lagging)
<i>Rating</i>	...	...	...	...	Continuous
<i>Speed</i>	...	...	...	...	8,000 r.p.m.
<i>Rotation (viewed on commutator end)</i>	...	...	...	...	Clockwise
<i>Maximum operational altitude</i>	...	...	50,000 ft.	...	(fan and blast cooling)
<i>Operational temperature range</i>	...	...	...	...	-55 deg. C to +50 deg. C
<i>Electrical connections—</i>					
<i>Input</i>	...	...	...	...	2 split terminal lugs
<i>Output</i>	...	3-pole miniature Mk. 4 plug	...	...	(Ref. No. 10H/9560060)
<i>Control panel interconnection</i>					
	...	12-pole miniature Mk. 4 plug	...	...	(Ref. No. 10H/9560150)
<i>Brush grade—</i>					
<i>d.c. input</i>	...	...	...	...	KC.EG.11 (Ref. No. 5UB/6128)
<i>a.c. output</i>	...	...	...	...	KC.CM.6 (Ref. No. 5UB/6486)
<i>Brush spring pressure—</i>					
<i>d.c. input</i>	...	...	...	...	20 to 24 oz.
<i>a.c. output</i>	...	...	...	...	4 to 5 oz.
<i>Brush length when new—</i>					
<i>d.c. input</i>	...	...	...	...	0.906 in.
<i>a.c. output</i>	...	...	...	...	0.687 in.
<i>Minimum brush length—</i>					
<i>d.c. input</i>	...	...	...	...	0.562 in.
<i>a.c. output</i>	...	...	...	...	0.375 in.
<i>Commutator diameter (new)</i>	...	...	...	...	2.0 ± 0.005 in.
<i>Commutator diameter (minimum permissible)</i>	...	...	...	...	1.875 in.
<i>Slip-ring diameter (new)</i>	...	...	...	...	0.812 <sup>+0.005</sup> <sub>-0</sub> in.
<i>Slip-ring diameter (minimum permissible)</i>	...	...	...	...	0.750 in.
<i>Depth of undercut</i>	...	...	...	...	0.025 ± 0.001 in.
<i>Width of slot</i>	...	...	...	...	0.025 ± 0.001 in.
<i>Commutator—</i>					
<i>Maximum eccentricity</i>	...	...	...	...	0.0005 in.
<i>Bar-to-bar variation</i>	...	...	...	...	0.0001 in.
<i>Weight</i>	...	...	...	...	30 lb. 12 oz.

RESTRICTED

1. The inverter, Type 103 (Rotax S3101) is generally similar in construction to that described and illustrated in the main chapter. It has two shunt field ballast resistors mounted in the a.c. housing; the internal connections are as shown in fig. 1.

2. The Type 103 inverter is used in conjunction with the control panel, Type 15 (Rotax U1502/2), or with panels Type 15 and 24 (Rotax U2401). The machine is con-

tinuously rated, giving a 115-volt, 400 c/s, 3-phase, 750-watt a.c. output at 0.9 leading to 0.8 lagging power factor, when supplied with a d.c. input of 25 to 28 volts. The design of the machine is, however, such as to meet a 1 kW pulsating load requirement for radar equipment.

3. It should be noted that the phase sequence is A-B-C, relative to the 3-pole output plug and NOT the stator markings.

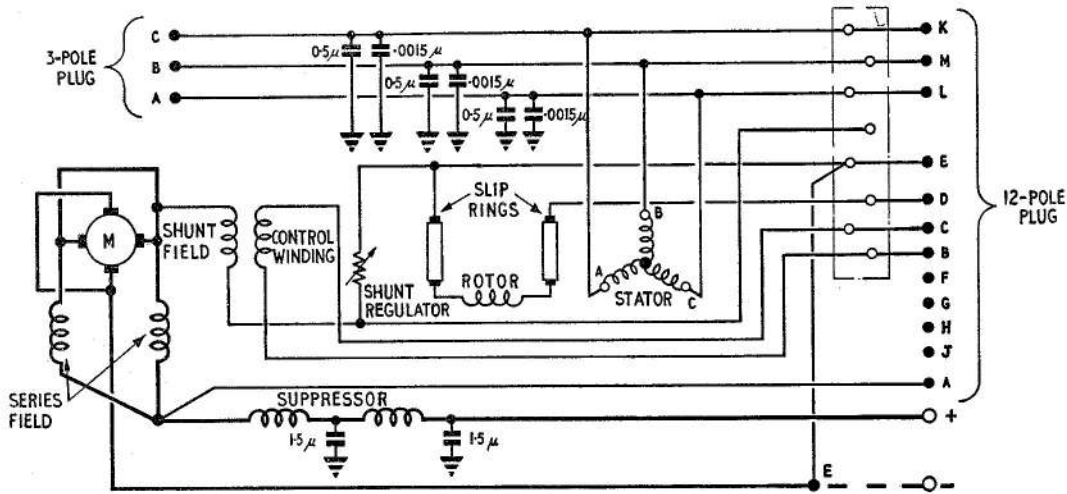

Fig. 1. Diagram of internal connections

RESTRICTED

## Appendix 2

### ROTARY INVERTER, TYPE 103A (ROTAX S3106/1)

#### LEADING PARTICULARS

<b>Inverter, Type 103A</b>	...	...	...	...	Ref. No. 5UB/6731
<i>Input</i>	...	...	...	...	25 to 28V d.c., 57.5 amp.
<i>Output</i>	...	...	...	115V, 3-phase a.c.,	4.85 amp., 400 c/s
<i>Rating</i>	...	...	...	...	Continuous
<i>Speed</i>	...	...	...	...	8,000 r.p.m.
<i>Rotation (viewed on commutator end)</i>	...	...	...	...	Clockwise
<i>Maximum operational altitude</i>	...	...	...	50,000 ft.	(fan and blast cooling)
<i>Operational temperature range</i>	...	...	...	...	-55 deg. C to +50 deg. C
<i>Output connection</i>	3-pole miniature Mk. 4 plug (Ref. No. 10H/9560060)				
<i>Control panel interconnection</i>	12-pole miniature Mk. 4 plug (Ref. No. 10H/9560150)				
<i>Brush grade—</i>					
<i>d.c. input</i>	...	...	...	...	KC.EG.11 (Ref. No. 5UB/6128)
<i>a.c. output</i>	...	...	...	...	KC.CM.6 (Ref. No. 5UB/6486)
<i>Brush spring pressure—</i>					
<i>d.c. input</i>	...	...	...	...	20 to 24 oz.
<i>a.c. output</i>	...	...	...	...	4 to 5 oz.
<i>Brush length when new—</i>					
<i>d.c. input</i>	...	...	...	...	0.906 in.
<i>a.c. output</i>	...	...	...	...	0.687 in.
<i>Minimum brush length—</i>					
<i>d.c. input</i>	...	...	...	...	0.562 in.
<i>a.c. output</i>	...	...	...	...	0.500 in.
<i>Commutator diameter (new)</i>	...	...	...	...	2.0 ± 0.005 in.
<i>Commutator diameter (minimum permissible)</i>	...	...	...	...	1.875 in.
<i>Slip-ring diameter (new)</i>	...	...	...	...	0.812 <sup>+0.005</sup> <sub>-0</sub> in.
<i>Slip-ring diameter (minimum permissible)</i>	...	...	...	...	0.750 in.
<i>Depth of undercut</i>	...	...	...	...	0.025 ± 0.001 in.
<i>Width of slot</i>	...	...	...	...	0.025 ± 0.001 in.
<i>Commutator—</i>					
<i>Maximum eccentricity</i>	...	...	...	...	0.0005 in.
<i>Bar-to-bar variation</i>	...	...	...	...	0.0001 in.
<i>Weight</i>	...	...	...	...	30 lb. 12 oz.

RESTRICTED

1. The inverter, Type 103A (Rotax S3106/1) is generally similar in construction to that described and illustrated in the main chapter. It has two shunt field ballast resistors mounted in the a.c. housing; the internal connections are as shown in fig. 1. This inverter differs from the Type 103 in having a separate shunt field input connection to give increased starting torque, the connection being an additional terminal S inside the suppressor box; it is essential when starting the machine that connection from the positive of the input supply should be made to this terminal.

2. The Type 103A inverter is used in conjunction with the control panel, Type 15 (Rotax U1502/2), or with panels Type 15 and 24 (Rotax U2401). The machine is continuously rated, giving a 115-volt, 400 c/s, 3-phase, 750-watt a.c. output at 0.9 leading to 0.8 lagging power factor, when supplied with a d.c. input of 25 to 28 volts. The design of the machine is, however, such as to meet a 1 kW pulsating load requirement for radar equipment.

3. It should be noted that the phase sequence is A-B-C, relative to the 3-pole output plug and NOR the stator markings.

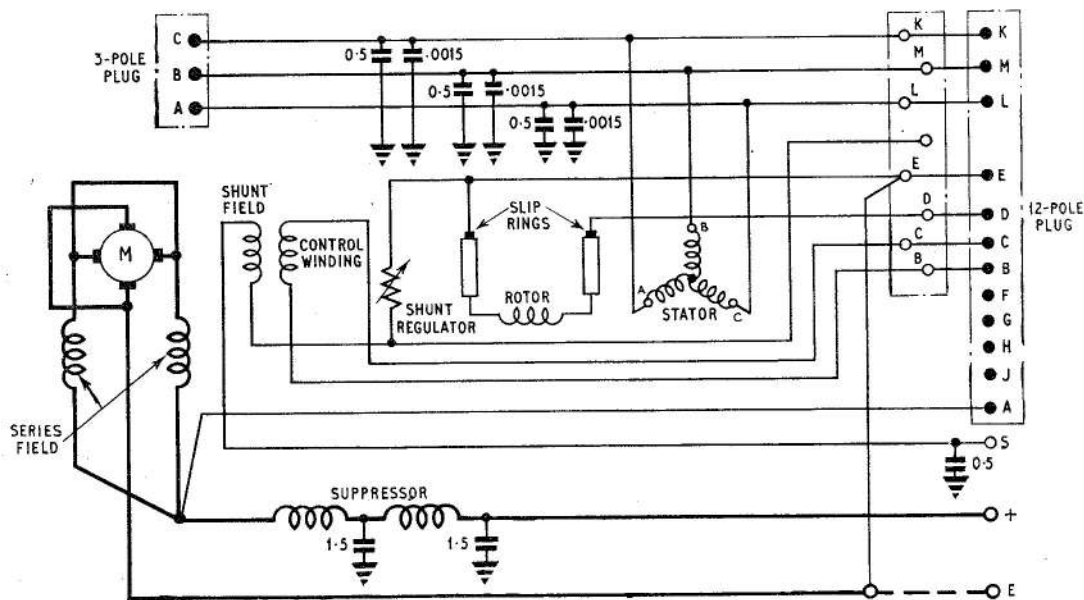

Fig. 1. Diagram of internal connections

RESTRICTED

Appendix 3

ROTARY INVERTER, TYPE 103B (ROTAX S3109)

LEADING PARTICULARS

Inverter, Type 103B	...	...	...	...	Ref. No. 5UB/6884									
Input	...	...	...	...	25 to 28V d.c., 57.5 A									
Output	...	...	...	...	3-phase, 400 c/s, 115V, a.c., 4.85A									
Speed	...	...	...	...	8,000 r.p.m.									
Rating	(Continuous at 35,000 ft. fan cooled. Blast air cooled to 50,000 ft.)													
Rotation	...	...	...	...	Clockwise (from commutator end)									
Maximum operational altitude	...	...	...	...	50,000 ft.									
Operational temperature range	...	...	...	...	-55 deg. C. to +100 deg. C.									
Electrical connections—														
Input	...	...	...	Two	<table border="0"> <tr> <td>{</td> <td>Glands</td> <td>A.G.S.1757/1</td> </tr> <tr> <td></td> <td>Nuts</td> <td>A.G.S.1658/0</td> </tr> <tr> <td></td> <td>Sleeves</td> <td>A.G.S.1733/2</td> </tr> </table>	{	Glands	A.G.S.1757/1		Nuts	A.G.S.1658/0		Sleeves	A.G.S.1733/2
{	Glands	A.G.S.1757/1												
	Nuts	A.G.S.1658/0												
	Sleeves	A.G.S.1733/2												
Output	...	...	...	3-pole miniature Mk. 4 plug	(2CZ.108431)									
Control panel interconnection	12-pole miniature Mk. 4 plug	(2CZ.84961)												
Brush length (new)—														
d.c. input	...	...	...	...	0.906 ± 0.010 in.									
a.c. output	...	...	...	...	0.687 ± 0.020 in.									
Brush length (minimum permissible)—														
d.c. input	...	...	...	...	0.562 in.									
a.c. output	...	...	...	...	0.500 in.									
Brush grade—														
d.c. input	...	...	...	...	KC.EG.11									
a.c. output	...	...	...	...	KC.CM.6									
Brush spring pressure—														
d.c. input	...	...	...	...	20 to 24 oz.									
a.c. output	...	...	...	...	4 to 5 oz.									
Commutator diameter (new)	...	...	...	...	2.0 ± 0.005 in.									
Commutator diameter (minimum permissible)	...	...	...	...	1.875 in.									
Slip-ring diameter (new)	...	...	...	...	0.812—0.817 in.									
Slip-ring diameter (minimum permissible)	...	...	...	...	0.750 in.									
Depth of undercut	...	...	...	...	0.025 ± 0.001 in.									
Width of slot	...	...	...	...	0.025 ± 0.001 in.									
Commutator—														
Maximum eccentricity	...	...	...	...	0.0005 in.									
Bar-to-bar variation	...	...	...	...	0.0001 in.									

RESTRICTED

## LEADING PARTICULARS — (continued)

*Overall dimensions—*

Length (over air spout) ... ..	16.696 in.
Height ... ..	8.116 in.
Width (over mounting feet) ... ..	6.374 in.

*Air requirements—*

Air temperature (deg. C)	Quantity (lb/min)
-10	1.4
+10	1.55
+30	1.8
+50	2.1
+70	2.5
+90	3.1

1. The inverter, Type 103B (Rotax S3109) is similar to that described in the main chapter; it is designed for high temperature operation with identical electrical characteristics to others in the series, and is used in conjunction with control panel, Type 15B (Rotax U1506), or with panels Type 15B and 24B (Rotax U2404).

2. High temperature materials are used for all connecting leads, conductors, coils, and brushgear mouldings. Uniefglas, Lewkanex 'M' together with impregnated raw glass tape, silicone resin bonded between armature coils, and glass filled alkyd A.M.C. 440 A.T.

material for both a.c. and d.c. brushgear mouldings respectively are incorporated for high temperature conditions.

3. Two 1.0  $\mu\text{F}$  capacitors (each consisting of two 0.5  $\mu\text{F}$  capacitors in parallel) are used for suppression. The shunt lead is brought out to a separate terminal S, which should be connected to the positive of the input supply before starting up the machine. The internal connections are as shown in fig. 1.

**Note . . .**

*The phase sequence is A-B-C relative to the 3-pole output plug.*

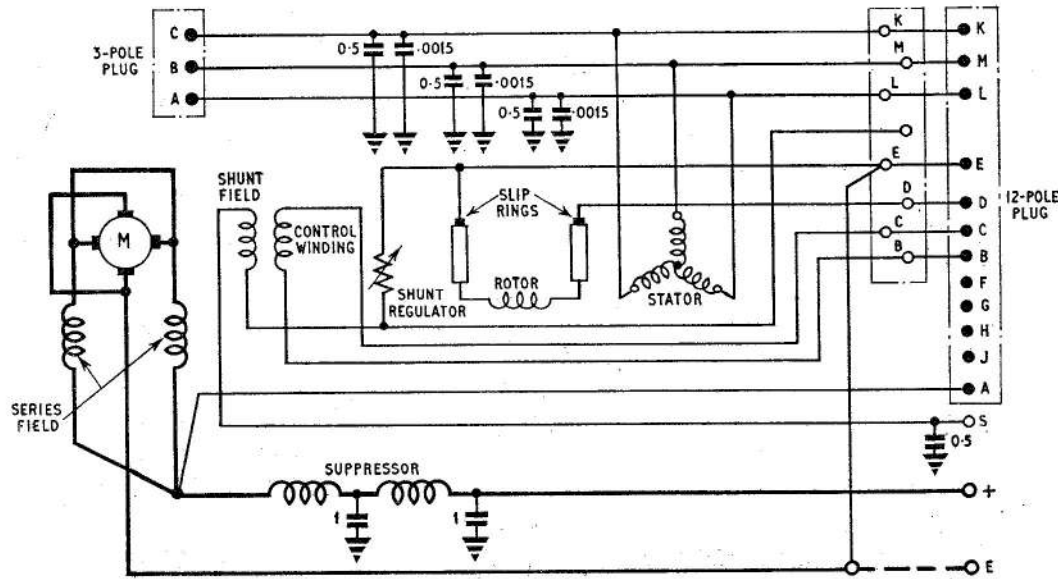

**Fig. 1. Diagram of internal connections**

**RESTRICTED**

## Appendix 4

### ROTARY INVERTER TYPE 103C (ROTAX S3110)

#### LEADING PARTICULARS

<i>Inverter, Type</i> ... ..	<i>Ref No.</i>
<i>Input</i> ... ..	25 to 28V d.c., 57.5 amp
<i>Output</i> ... ..	115V, 3-phase a.c., 4.85 amp., 400 c/s
<i>Rating</i> ... ..	Continuous
<i>Speed</i> ... ..	8,000 rev/min.
<i>Rotation (viewed on commutator end)</i> ... ..	Clockwise
<i>Maximum operational altitude</i> ... ..	35,000 ft. (Fan cooled)
<i>Operational temperature range</i> ... ..	-55 deg. C to +50 deg. C
<i>Electrical connections</i>	
<i>Input</i> ... ..	2 split terminal lugs
<i>Output</i> ... ..	3-pole miniature Mk. 4 plug (Ref. 10H/9560060)
<i>Control panel interconnection</i> ... ..	12-pole miniature Mk. 4 plug (Ref. No. 10H/9560150)
<i>Brush grade</i>	
<i>d.c. input</i> ... ..	PEG 11
<i>a.c. output</i> ... ..	KC.CM6 (Ref. No. 5UB/6486)
<i>Brush spring pressure</i>	
<i>d.c. input</i> ... ..	20 to 24 oz.
<i>a.c. output</i> ... ..	4 to 5 oz.
<i>Brush length when new</i>	
<i>d.c. input</i> ... ..	0.906 in.
<i>a.c. output</i> ... ..	0.687 in.
<i>Minimum brush length</i>	
<i>d.c. input</i> ... ..	0.562 in.
<i>a.c. output</i> ... ..	0.531 in.
<i>Commutator diameter (new)</i> ... ..	2.0 ± 0.005 in.
<i>Commutator diameter (minimum permissible)</i> ... ..	1.875 in.
<i>Slip ring diameter (new)</i> ... ..	0.812 + 0.005 - 0 in.
<i>Slip ring diameter (minimum permissible)</i> ... ..	0.750 in.
<i>Depth of undercut</i> ... ..	0.025 ± 0.001 in.
<i>Width of slot</i> ... ..	0.025 ± 0.001 in.
<i>Commutator</i>	
<i>Maximum eccentricity</i> ... ..	0.0005 in.
<i>Bar-to-bar variation</i> ... ..	0.0001 in.
<i>Weight</i> ... ..	30.75 lb.

1. This inverter is similar to the Type 103A. (Rotax S3106/1), the only difference being that the Type 103A is fitted with an air inlet assembly, at the d.c. end, for blast cooling and the Type 103C is fitted with an end screen assembly, at the d.c. end, for internal fan cooling only.

2. The type 103C inverter is used in conjunction with the control panel, Type 15 (Rotax U1502/2), or with panels Type 15

and Type 24 (Rotax U2401). The machine is continuously rated, giving a 115V, 400 c/s, 3-phase, 750 watt a.c. output at 0.9 leading to 0.8 lagging power factor, when supplied with a d.c. input of 25 to 28 volts. The machine will, however, meet a 1 kW pulsating load requirement for radar equipment.

3. It should be noted that the phase sequence is A-B-C, relative to the 3-pole output plug and not the stator markings.

### RESTRICTED

This file was downloaded  
from the RTFM Library.

Link: [www.scottbouch.com/rtfm](http://www.scottbouch.com/rtfm)

Please see site for usage terms,  
and more aircraft documents.

