

## Chapter II

### ROTARY INVERTER, TYPE 300

#### LIST OF CONTENTS

	Para.		Para.
Introduction ... ..	1	Testing requirements ... ..	10
Description ... ..	2	Tests	
Servicing ... ..	7	Inverter, without suppressor unit ... ..	13
Bearings ... ..	8	Neutral setting ... ..	14
Brushes ... ..	9	Insulation resistance test ... ..	17
		Inverter, with suppressor unit ... ..	18

#### LIST OF ILLUSTRATIONS

	Fig.		Fig.
Rotary inverter, Type 300 ... ..	1	Circuit diagram ... ..	3
Sectional view of inverter ... ..	2		

#### LEADING PARTICULARS

Rotary inverter, Type 300 ... ..	Stores Ref. 5U/5398
Input voltage ... ..	27.5-volt d.c.
Output ... ..	30 to 37-volt d.c. single-phase 50 volt-amps, 1,500 c/s (11,250 r.p.m.)
Rating (running light) ... ..	Continuous
(peak load) ... ..	4.5 amp. for ½ minute
Overall dimensions of base ... ..	7¼ in. × 4 in.
Overall height ... ..	4.4 in.
Weight, including suppressor unit ... ..	4 lb. 8 oz.
Brush grade ... ..	E.G.O. (H.A.)
Brush spring pressure ... ..	3¼ oz. to 4¼ oz.

#### Introduction

1. The rotary inverter, Type 300 (fig. 1), is designed to provide single-phase a.c. for gun-firing installations, and consequently will run only intermittently. With an input of 27.5 volt, d.c., it delivers an output of 50 volt-amps, at 30 to 37 volt a.c., with a frequency of 1,500 c/s, at unity power factor, and a speed of 11,250 r.p.m. The base of the machine incorporates a suppressor unit.

#### DESCRIPTION

2. The rotary inverter, Type 300, (a sectional view of which is shown in fig. 2), is a two-pole, compound wound machine. The series and shunt field d.c. windings (X-XX), and the a.c. field output winding (A1-A2), are carried on a common stator assembly.

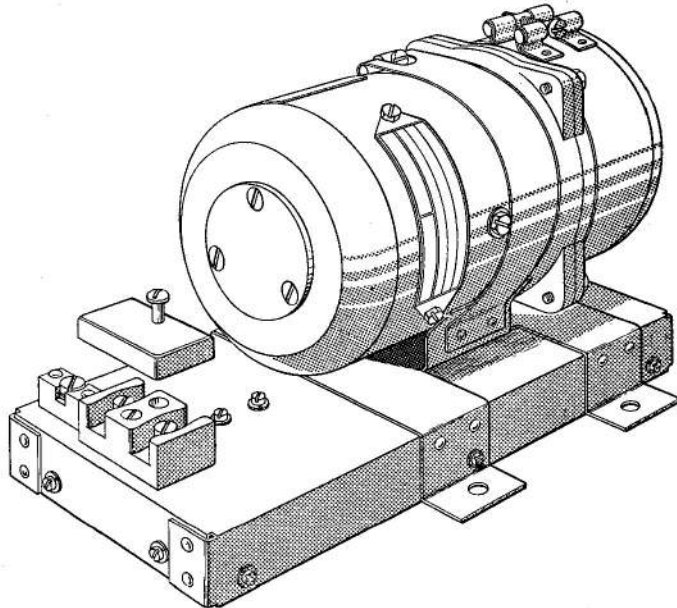

Fig. 1. Rotary inverter, Type 300

(A.L.I, Sep. 57)

3. The inverter is of conventional design, the armature shaft rotating in ball bearings housed in the stator frame and the end shield respectively. The former is fitted with a bearing cover secured to the stator frame by three screws; the latter is protected by a bearing end cap, within which is fitted a pre-loading washer, the whole being secured to the end shield by three screws.

4. Access to the d.c. brushgear is by removal of the window strap fitted to the end shield. The brush carrier is slotted to allow adjustment of the brush position; the optimum position being marked. Brush pressure is maintained by clock-type springs which bear on the top of each brush, and is not adjustable.

5. Access to the stator windings is by removal of the window assembly fitted to the stator frame. The stator assembly is secured to the stator frame by two screws, one at each side of the machine, and the end shield is held to the stator frame by four hex. hd. screws and shakeproof washers.

6. The inverter unit is mounted on a base, within which are housed the components of the suppressor unit. A circuit diagram of the inverter is given in fig. 3. A two-way terminal block is fitted at one end of the base, adjacent to the earth terminal. The terminal block is suitable for 4-amp. and 6-amp. cable lugs. The base is fitted with four mounting feet.

#### SERVICING

7. General information on the servicing of inverters will be found in A.P.4343, Vol. 1, Sect. 8.

#### Bearings

8. The bearings are lubricated with grease XG-275 (Stores Ref. 34B/9100512), and should not require attention between major servicing periods.

#### Brushes

9. Details of the brush grade, and the correct brush spring pressure are given under Leading Particulars.

#### Testing requirements

10. The full test load is 1.5 amperes at unity power factor, 30 to 37 volts r.m.s., 1,500 c/s at a speed of 11,250 r.p.m.

11. Commutation must be good under all conditions.

12. Alternating current measurements must be made with low power r.m.s. reading meters.

#### TESTS

##### Inverter, without suppressor unit

13. With the brushgear set in the mid-position, bed the brushes to give contact over the whole arc, and at least 80 per cent of the area, by running light on approximately 20 volts, and ensure that the direction of rotation is counter-clockwise at the commutator end.

##### Neutral setting

14. For this test the field must be separately excited at constant voltage between 20 and 28 volts d.c. With 27.5 volts d.c., applied to the armature circuit, and the field voltage kept constant, determine the drop in speed from no-load to full-load for both directions of rotation. The drop in speed for either

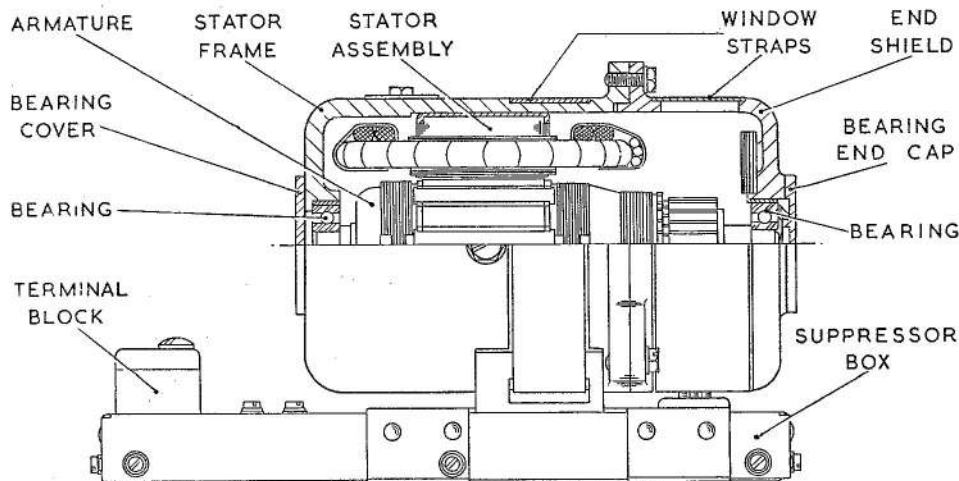

Fig. 2. Sectional view of inverter

RESTRICTED

rotation should differ by not more than 200 r.p.m., the drop in speed for normal rotation being the greater. If the machine speed is outside these limits, correct by adjusting the brush position. When the neutral position has been obtained, run the machine light until thoroughly warm and repeat the test, resetting if necessary.

15. Determine the input current, and the output voltage on no-load, and 1.5 amperes output at unity power factor, and 27.5 volts input.

16. With the machine hot after running light until thoroughly warm on 27.5 volts input; the input current, output voltage, and speed must be within the following limits:—

Alternating current (amp.)	Input current (amp.)	Output volts	Speed r.p.m.
0	1.6 (max.)	48.0 to 55.0	10,500 ± 10 per cent.
1.5	4.1 (max.)	32.0 to 39.0	9,650 ± 10 per cent.

**Note . . .**

To avoid possible damage to the inverter, due to overheating, care must be exercised during testing procedure, to ensure that the machine is NOT run on peak load for a period exceeding half-a-minute, see Leading Particulars.

**Insulation resistance test**

17. The insulation resistance between the windings and the frame, when measured with a 250-volt insulation resistance tester must not be less than 50,000 ohms.

**Inverter, with suppressor unit**

18. Repeat test as described in para. 15, after running light on 27.5 volts d.c. input, making the negative connection via the earth terminal. The limits for the input current and the output voltage are as follows:—

Alternating current (amp.)	Input current (amp.)	Output volts
0	1.6 (max.)	48.0 to 55.0
1.5	4.1 (max.)	30.0 to 37.0

19. With the earth removed, and the machine hot from the previous test, measure the insulation resistance value of all windings to the frame, using a 250-volt. insulation resistance tester. The value must not be less than 50,000 ohms.

20. Replace the earth connection, and ensure that the performance is satisfactory on full-load, making the negative connection via the earth terminal.

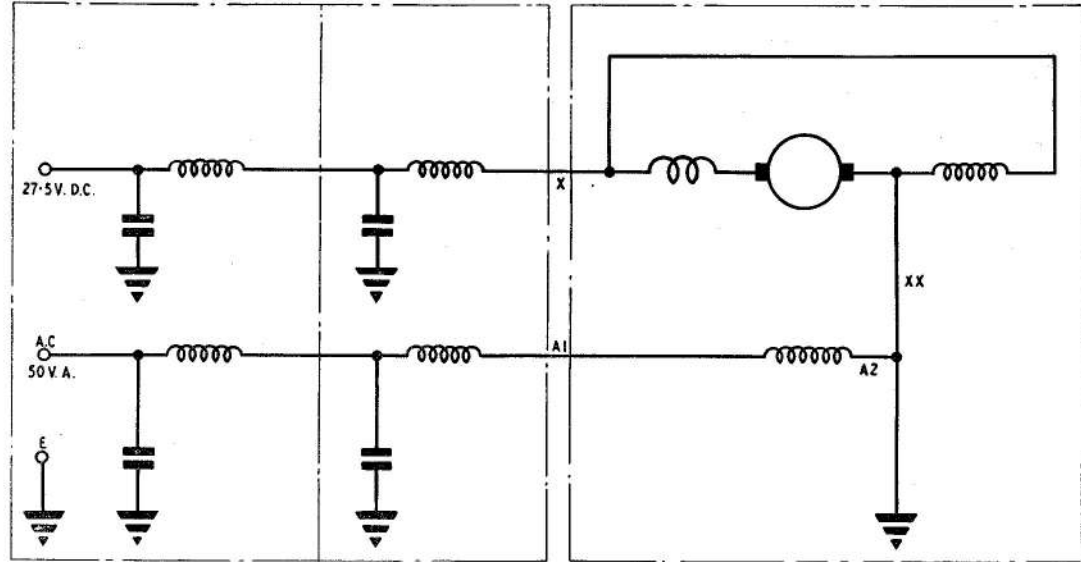

Fig. 3. Circuit diagram

This file was downloaded  
from the RTFM Library.

Link: [www.scottbouch.com/rtfm](http://www.scottbouch.com/rtfm)

Please see site for usage terms,  
and more aircraft documents.

