

See AP 113D-0109-16
113D-0110-16

Chapter 13

ROTARY INVERTERS, ROTAX, S3300 SERIES

LIST OF CONTENTS

	<i>Para.</i>		<i>Para.</i>
<i>Introduction</i>	1	Installation	13
Description	2	Servicing	16
<i>Suppressor unit</i>	8	<i>Brushgear</i>	17
<i>Cooling</i>	9	<i>Commutator and slip rings</i>	19
<i>Operation</i>	11	<i>Lubrication</i>	20
		<i>Testing</i>	21

LIST OF ILLUSTRATIONS

	<i>Fig.</i>
<i>Typical schematic diagram</i>	1

LIST OF APPENDICES

	<i>App.</i>		<i>App.</i>
<i>Standard servicability test for rotary inverters, Rotax, S3300 series</i>	A	<i>Rotary inverter, Type 108 (Rotax S3303)</i>	2
<i>Rotary inverter, Type 112 (Rotax S3302)</i>	1	<i>Rotary inverter, Type 108A (Rotax S3304)</i>	3
		<i>Rotary inverter, Rotax, Type S3307</i> ...	4

RESTRICTED

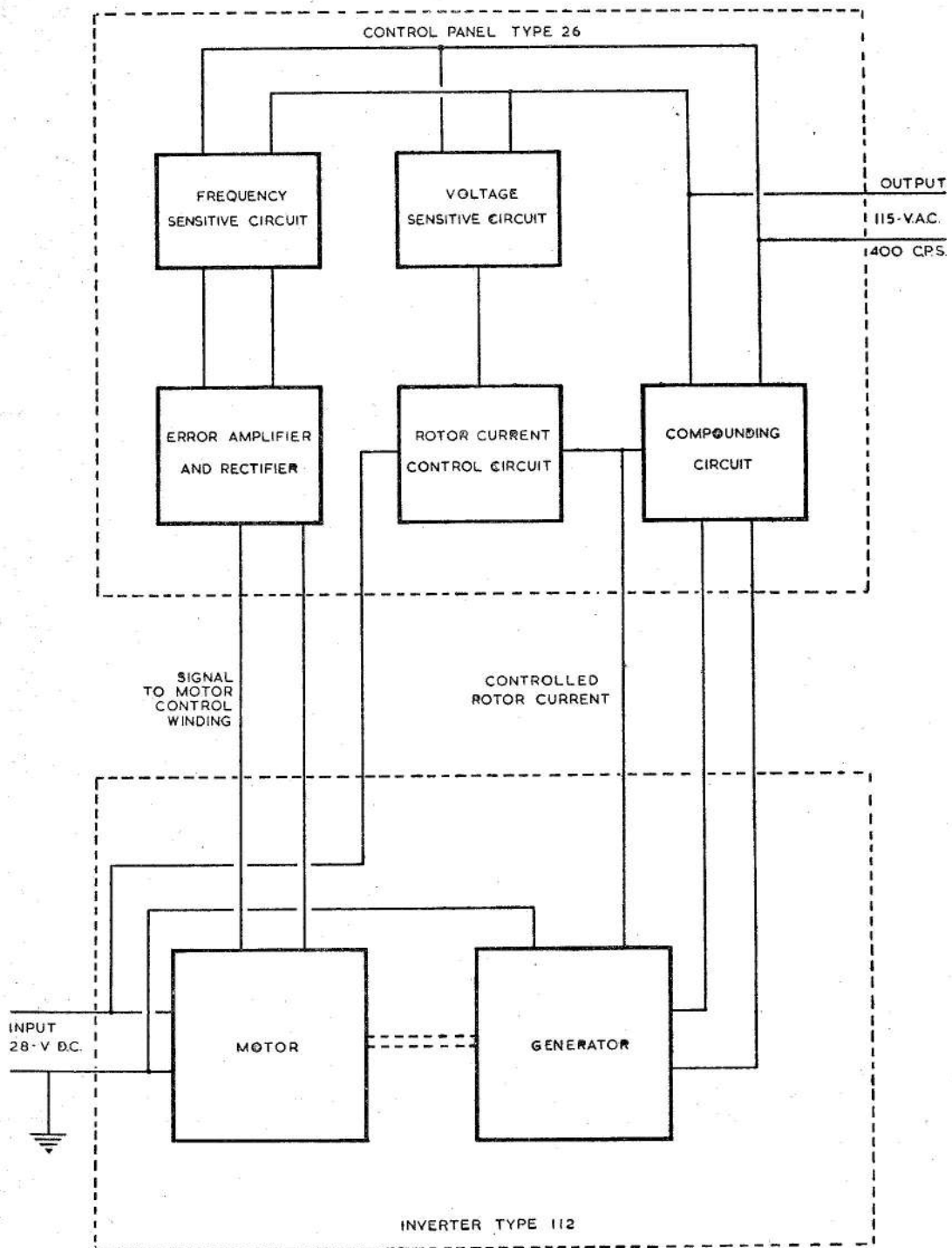

Fig. 1. Typical schematic diagram

RESTRICTED

Introduction

1. The S3300 series of rotary inverters is designed to operate in conjunction with a control panel of the U1500 series to give an output of 115V, 400 c/s, single-phase a.c. from a 25-29V d.c. input; it also requires a starting switch of the U2000 series in the input circuit. Details of individual machines will be found in Appendices to this chapter.

DESCRIPTION

2. The inverter consists of a 25-29V d.c. compound wound, 4-pole motor, driving a 115V a.c. 400 c/s, 6-pole generator. The motor armature and the generator rotor are mounted on a common shaft which runs in a roller bearing at the motor end and a ball bearing at the generator end.

3. The unit is housed by three main castings, i.e. the motor housing, motor yoke, and generator housing. The motor yoke is spigoted at each end and is clamped between the motor and generator housings by four external bolts inserted in lugs. At each end of the machine is an end casting embodying the appropriate air inlet or exhaust, and held in place by a retaining strap and clamping bolt.

Note . . .

In machines fitted with a piped air inlet, drain holes have been introduced by modification action to allow accumulated moisture to drain away. The housings have also been treated with a protective resin finish as an anti-corrosive measure. ▶

4. The four motor poles are bolted to the interior of the motor yoke; they are energized by three separate windings, the main or series winding, a shunt winding and a control winding which receives the frequency control signal from the control panel with which the inverter is associated.

5. The d.c. brushgear is bolted to the roller bearing support (integral with the motor housing). It has four brushes which are maintained in contact with the commutator by coil springs. Access to the brushes is gained by removing a clip-retained cover band which seals four inspection windows in the motor housing.

6. The stator of the generator is fitted in the generator housing and is positioned by a bolt passing through the top of the housing

which locates in a slot in the stator. The stator incorporates the output winding of the generator.

7. The rotor is the generator d.c. field and is energized by a controlled d.c. supply from the associated control panel. The supply is connected to the rotor winding by four brushes in contact with slip rings on the shaft, situated outside the generator end ball bearing. The brushgear is bolted to the ball bearing support (integral with the generator housing). There are four brushes spaced radially at 90 deg., two adjacent brushes making contact with the positive slip ring and the remaining two with the negative slip ring. Brush pressure is maintained by brush triggers loaded by coil springs. An adjustable shunt field resistor, which determines the motor shunt field current, is mounted close above the a.c. brushgear. Access to the a.c. brushgear and the shunt resistor is gained by removing a clip-retained cover band from the generator housing.

Suppressor unit

8. The suppressor unit contains the capacitors and chokes (if fitted) comprising the suppression circuit, and also a terminal block for the internal a.c. and d.c. connections. The main d.c. supply is connected to cable lugs. The a.c. output is taken via a 2-pole miniature Mk. 4 socket, whilst the interconnection between the inverter and its control panel is made through a 6-pole socket. Access to the suppressor unit is obtained by removing the top cover.

Cooling

9. For low altitudes, cooling is effected by two impellers, one mounted at the commutator end and the other at the slip ring end. Air is drawn in through the inlet at the commutator end, and is expelled through the outlet at the a.c. end.

10. For high altitudes, blast cooling is employed; the blast air requirements are given in the following table.

Air temperature (deg. C)	Cooling air requirements (lb/min.)
-30	1.30
-15	1.40
+5	1.60
+25	1.84
+45	2.20

RESTRICTED

Operation

11. Current is supplied to the positive d.c. terminal from a 28V d.c. supply. The d.c. negative may be connected to earth, for earth return systems, or the negative terminal may be connected to a d.c. negative line. When supply is switched on, current flows through the main series field and the motor armature to negative, and also through the shunt field and shunt resistor to negative. The motor rotates, driving the generator rotor, and the energized rotor field generates a single-phase a.c. supply in the stator winding. This a.c. supply is fed directly to the 2-pole socket as the output of the inverter.

12. The inverter operates in conjunction with a control panel of the U1500 series; a typical schematic diagram, showing a Type 112 inverter (Rotax S3302) used with a Type 26 control panel (Rotax U1504), is shown in fig. 1. The control panel senses errors in the voltage and frequency of the inverter output; the frequency correction signal from the panel is applied to the control winding of the motor, thereby regulating the speed of the inverter. On starting, the alternator rotor winding is excited by d.c. tapped from the main d.c. input, and led through a contactor in the control panel. When the inverter has started and the control voltage is approached, the contactor opens and the rotor is from then on excited by the rectified outputs of the compounding circuit and the voltage control circuit which maintains a controlled voltage.

INSTALLATION

13. The inverter is normally secured by four mounting feet, each with a 0.312 in. dia. fixing hole. The machine may be mounted in any position, but one in which it is normally horizontal is preferable.

14. Provision for adequate circulation of free air in and around the unit must be made, and if blast cooling is to be employed then suitable arrangements must be made for a blast air supply.

15. Interconnection between the inverter and its associated control panel should be with screened cables; all cable runs should be kept as short as possible.

SERVICING

16. These inverters should be serviced in accordance with the general chapter in A.P.4343, Vol. 1, Sect. 8, Chap. 2, and the instructions contained in the relevant Servicing Schedule.

Brushgear

17. Access to the brushgear is gained by removal of the cover band after releasing its clip, at each end. The minimum brush length beyond which brushes must not be used is quoted in the relevant Appendix; brushes should be renewed at periods prescribed in the appropriate Servicing Schedule, and whenever examination reveals that they will not remain serviceable for the period that must elapse before the next servicing.

18. Brush spring pressure, measured with a suitable tension gauge, should be within the limits quoted in the relevant Appendix.

Commutator and slip rings

19. The commutator and slip rings should be examined for signs of wear, scoring or burning. If re-surfacing is necessary, it should be noted that the minimum commutator diameter and slip ring diameter are as quoted in the relevant Appendix.

Lubrication

20. Bearings are lubricated by the manufacturer with grease XG-271, which should be used if further lubrication is necessary.

Testing

21. If the serviceability of the inverter is suspect, it may be tested as laid down in Appendix A.

RESTRICTED

Appendix A

STANDARD SERVICEABILITY TEST FOR ROTARY INVERTERS, ROTAX, S3300 SERIES

Introduction

1. The following tests may be applied to the machine before it is put into service, or at any time when its serviceability is suspect.

Test equipment

2. The following test equipment is required:—

- (1) Insulation resistance tester, Type C (Ref. No. 5G/152).
- (2) Inverter tester (Ref. No. 5G/564).
- (3) Variable reactive load (Ref. No. 5G/3273).
- (4) Control panel, Type 26.
- (5) Starting switch, Type 1A, No. 5 (Rotax U2005/1).

Testing

Insulation resistance test

3. The insulation resistance, measured with a 250-volt insulation resistance tester between the following points, should not be less than 50,000 ohms.

Note . . .

Before commencing the test, ensure that the suppression capacitors are isolated from the frame.

- (1) *Between the positive brush box and frame, and between pole B of the 6-pole socket and frame.*
- (2) *Between the stator circuit and (a) frame, (b) the positive brush box, and (c) pole B of the 6-pole socket.*

Performance test

4. The following external connections should be made before the machine is run.

(1) *Control winding circuit.* Using an auxiliary d.c. supply (0-50V), connect positive to pin B (6-pole plug), and connect the negative through a suitable ammeter and variable resistor to pin C (6-pole plug).

Note . . .

With inverters which have a separate shunt field terminal S, this terminal must be connected to the positive of the input supply, or, when a starter is used, to the supply side of the starter.

(2) *Rotor circuit.* Connect a suitable ammeter and variable resistor between pins A and D (6-pole plug).

Note . . .

When starting up switch on the auxiliary supply first, and set the current to 0.4 amp. When shutting down, switch off the auxiliary supply last.

5. Run the machine on full load (115V, 770W, 0.84 p.f. lag; S3302, 276W, 0.8 p.f. lag) at an input of 25 volts, and a speed of 8,000 r.p.m. (or frequency of 400 c/s). At the end of this run:—

- (1) The input current must not exceed 66 amp. (S3302, 34.5 amp.).
- (2) The control current must not be less than 0.125 amp. (S3302, 0.120 amp.).
- (3) The rotor current must be 3.75-4.4 amp. (S3302, 2.25-2.65.).

6. Immediately after the above test, run the machine on no load at an input of 29 volts, with an output voltage of 115 volts and a speed of 8000 r.p.m. Then:—

RESTRICTED

(1) The input current must not be greater than 19 amp. (S3302, 15.5 amp.).

(2) The control current must not exceed 0.370 amp. (S3302, 0.350 amp.).

(3) The rotor current must be 2.2-2.7 amp. (S3302, 1.35-1.7 amp.).

Functioning test

7. The inverter should be started and run in conjunction with a Type 26 control panel, and a starting switch, Type 1A, No. 5 (Rotax U2005/1). For this test the following procedure should be adopted.

(1) Remake the suppression box connections.

(2) Adjust the open-circuit supply voltage to 26 volts, and switch on the inverter with no load across the output.

Note . . .

The open-circuit supply voltage may be increased if the regulation of the supply is poor.

(3) Whilst the inverter is running, switch on full load and re-adjust the supply voltage until the input terminal voltage is 25 volts. The machine should be allowed to run under these conditions for a period of 10 minutes, at the end of which time the output voltage and frequency should be recorded.

(4) Immediately after recording the above values, switch off the load on the output of the machine and increase the input terminal voltage to 28 volts. Record the output voltage and frequency.

8. In each instance, the output line voltage must be between 113 and 117 volts, and the output frequency between 398 and 402 c/s. The unbalance in the line voltages between any pair of lines must not exceed 2 volts.

RESTRICTED

See AP113D-0110-16

Held 'C'

Appendix 1

ROTARY INVERTER, TYPE 112 (ROTAX S3302)

LEADING PARTICULARS

Inverter, Type 112 (Rotax S3302)	Ref. No. 5UB/6505
Input voltage	25-29 volts d.c.
Output—									
Voltage	115V, single-phase a.c.
Frequency	400 c/s
Power (rated)	200W, 0.8 power factor (lagging)
Input brushes—									
Brush grade	PEG11
Spring pressure	6.75-8.25 oz. (192-233 gm.)
Length when new	0.781 ± 0.010 in.
Minimum permissible length	0.437 in.
Output brushes—									
Brush grade	KCEG11
Spring pressure	4.5 oz. (114-141 gm.)
Length when new	0.697 ± 0.010 in.
Minimum permissible length	0.531 in.
Rating	Continuous
Speed	8000 r.p.m.
Rotation (viewed on commutator end)	Clockwise
Cooling	Fan
Temperature range	-65 deg. C. to +70 deg. C.
Electrical connections—									
Input	Two 2 B.A. studs One 2 B.A. screw
Output	2-pole miniature Mk. 4 socket (CZ49217) (Ref. No. Z560230)
Control panel interconnection	6-pole miniature Mk. 4 socket (CZ49223) (Ref. No. Z560260)
Minimum commutator diameter	2.187 in.
Minimum slip ring diameter	0.75 in.
Overall dimensions—									
Length	12.093 in.
Width	6.375 in.
Height	7.718 in.
Weight	23.5 lb.

RESTRICTED

1. The inverter, Type 112 (Rotax S3302) is generally similar in construction to that described in the main chapter. A general view is given in fig. 1, and the internal connections are shown in fig. 2. When used in conjunction with a control panel, Type 26 (Rotax U1504), it will give an output of 115-volts, 400 c/s, single-phase a.c. from a 25-29 volt d.c. input, supplying 200W at a lagging power factor of 0.8. It is used with a starting switch, Type 1A, No. 5 (Rotax U2005/1), and must not be started up on load.

2. Natural cooling is employed for this machine. Cooling air enters through a gauze screen at the d.c. end, and leaves through a gauze outlet at the a.c. end.

3. A combined suppressor and connection box is mounted on top of the machine. At one end are the cable entries for the d.c. supply leads; at the other are fitted the 2-pole a.c. output socket, and the 6-pole socket for interconnection to the control panel. The d.c. input terminals are two 2 B.A. studs and a 2 B.A. screw for the separate shunt field connection (terminal S). This terminal is connected to the input side of the starting switch.

4. The inverter has four fixing holes 0.312 in. dia., with centres 7.240 in. by 5.625 in.

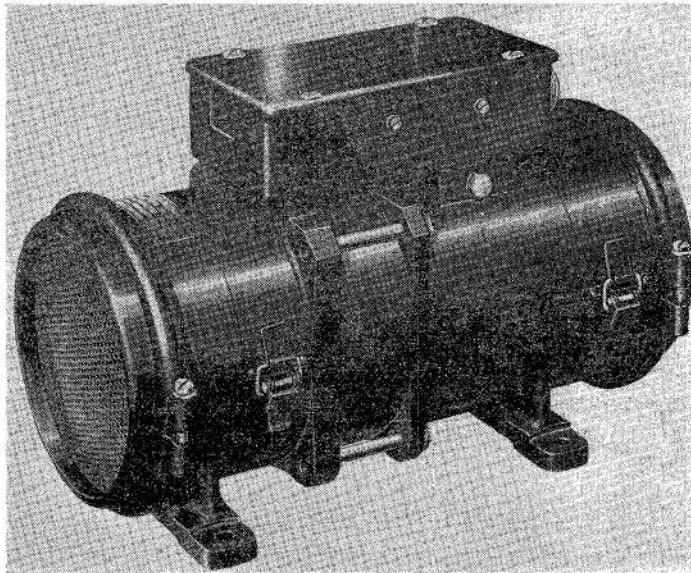

Fig. 1. General view of Type 112 inverter

RESTRICTED

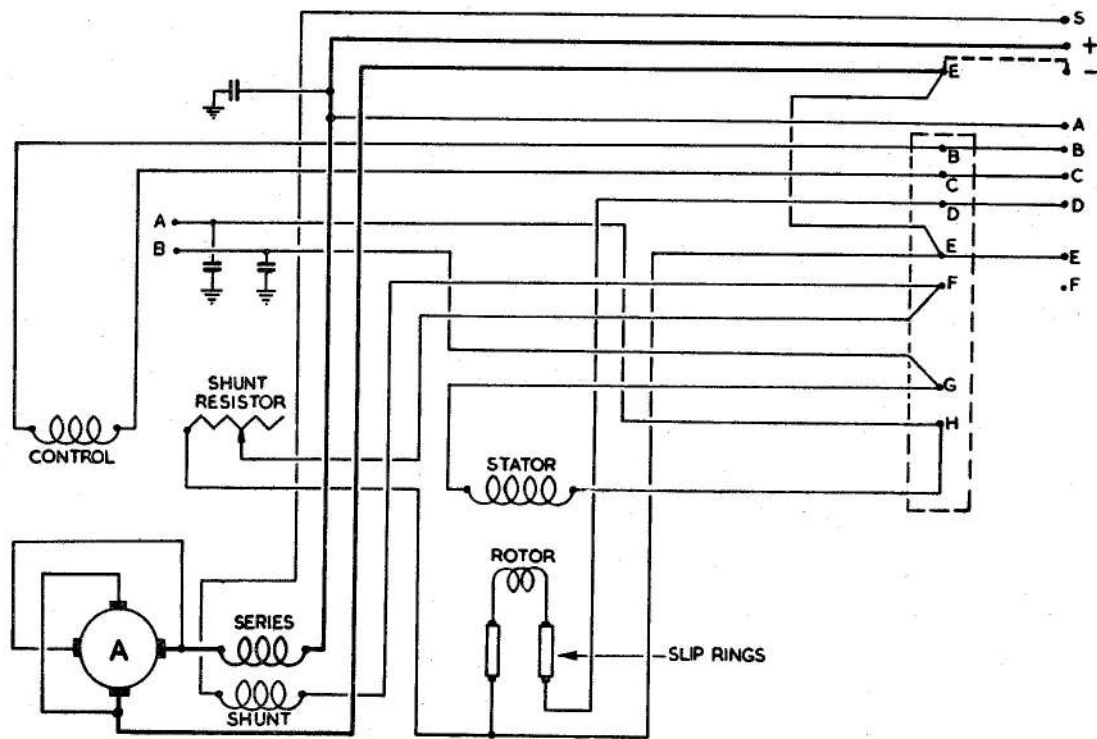

Fig. 2. Diagram of internal connections

RESTRICTED

See AP 113D-0109-16

held 'C'

Appendix 2

ROTARY INVERTER, TYPE 108 (ROTAX S3303/1)

LEADING PARTICULARS

Inverter, Type 108 (Rotax S3303/1)...	Ref. No. 5UB/5953
Input voltage	25-28 volts d.c.
Output—					
Voltage	115V, single-phase a.c.
Frequency	400 c/s
Power (rated)	770W, 1.0-0.84 power factor (lagging) or 650W, 1.0-0.95 power factor (leading)
Input brushes—					
Brush grade	KCEG11
Spring pressure	20-24 oz. (567-680 gm.)
Length when new	0.906 ± 0.010 in.
Minimum permissible length	0.562 in.
Output brushes—					
Brush grade	KCEG11
Spring pressure	4-5 oz. (114-141 gm.)
Length when new	0.697 ± 0.010 in.
Minimum permissible length	0.531 in.
Rating	Continuous
Speed	8000 r.p.m.
Rotation (viewed on commutator end)	Clockwise
Cooling...	Fan to 35,000 ft. Blast to 60,000 ft.
Temperature range	-65 deg. C. to +70 deg. C.
Electrical connections—					
Input	Cable gland nut and sleeve
Output	2-pole miniature Mk. 4 socket (CZ49217) (Ref. No. Z560230)
Control panel interconnection	6-pole miniature Mk. 4 socket (CZ49223) (Ref. No. Z560260)
Minimum commutator diameter	1.875 in.
Minimum slip ring diameter	0.75 in.
Overall dimensions—					
Length	16.625 in.
Width	6.375 in.
Height	7.968 in.
Weight	30.5 lb.

RESTRICTED

1. The inverter, Type 108 (Rotax S3303/1) is generally similar in construction to that described in the main chapter. A sectional view is given in fig. 1, and the internal connections are shown in fig. 2. When used in conjunction with a control panel, Type 26 (Rotax U1504), it will give an output of 115-volts, 400 c/s, single-phase a.c. from a 25-28 volts d.c. input, supplying either (a) 770W at a lagging power factor of between 1.0 and 0.84, or (b) 650W at a leading power factor of between 1.0 and 0.95. It is used with a starting switch, Type 1A, No. 5 (Rotax U2005/1), and must not be started up on load.

2. Natural cooling is employed up to 35,000 ft., and blast cooling for altitudes above that and up to 60,000 ft. The direction

of cooling air is from d.c. to a.c., and the connections may be reversed according to which type of cooling is to be employed; for natural cooling a gauze inlet and piped outlet are used, but for blast cooling a piped inlet and gauze exhaust. The piped connection may be set in any radial position.

3. A combined suppressor and connection box is mounted on top of the machine. At one end is fitted the 2-pole a.c. output socket, and at the other end the 6-pole socket for interconnection to the control panel, and two cable gland entries for the d.c. supply leads.

4. There are four fixing holes 0.312 in. dia., with centres 9.625 in. (axially) by 5.625 in.

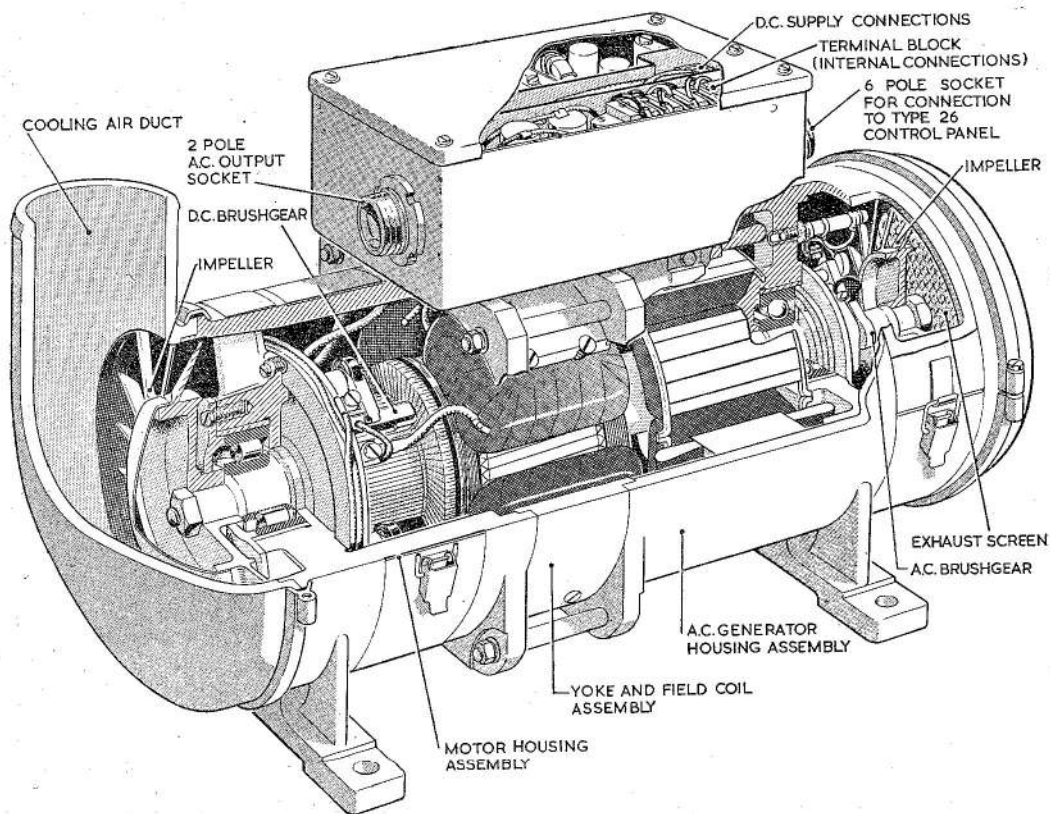

Fig. 1. Sectional view of inverter

RESTRICTED

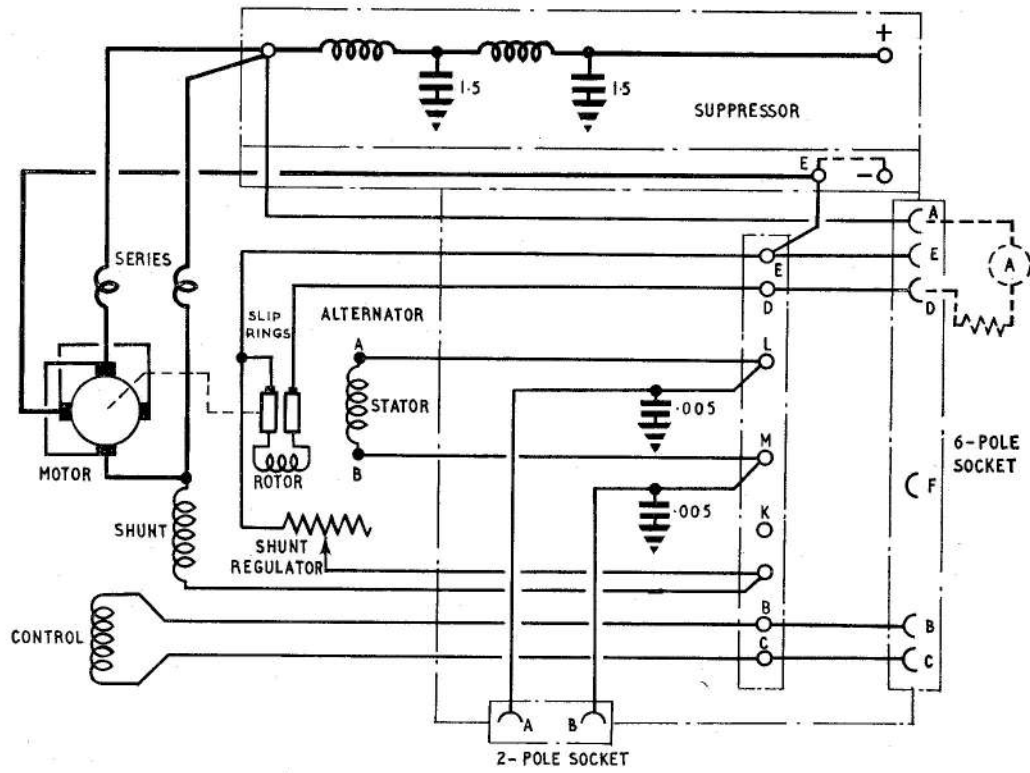

Fig. 2. Circuit diagram

RESTRICTED

See AP 113D-0109-16
held c

Appendix 3

ROTARY INVERTER, TYPE 108A (ROTAX S3304)

LEADING PARTICULARS

Inverter, Type 108A (Rotax S3304)	Ref. No. 5UB/
Input voltage	25-28 volts d.c.
Output—				
Voltage	115V, single-phase a.c.
Frequency	400 c/s
Power (rated)	770W, 1.0-0.84 power factor (lagging) or 650W, 1.0-0.95 power factor (leading)
Input brushes—				
Brush grade	KCEG11
Spring pressure	20-24 oz. (567-680 gm.)
Length when new	0.906 ± 0.010 in.
Minimum permissible length	0.562 in.
Output brushes—				
Brush grade	KCEG11
Spring pressure	4.5 oz. (114-141 gm.)
Length when new	0.697 ± 0.010 in.
Minimum permissible length	0.531 in.
Rating	Continuous
Speed	8000 r.p.m.
Rotation (viewed on commutator end)	Clockwise
Cooling	Fan to 35,000 ft. Blast to 55,000 ft.
Electrical connections—				
Input	Cable gland nut and sleeve
Output	2-pole miniature Mk. 4 socket (CZ49217) (Ref. No. Z560230)
Control panel interconnection	6-pole miniature Mk. 4 socket (CZ49223) (Ref. No. Z560260)
Minimum commutator diameter	1.875 in.
Minimum slip ring diameter	0.75 in.
Overall dimensions—				
Length	16.980 in.
Width	6.375 in.
Height	8.116 in.
Weight	30.5 lb.

1. The inverter, Type 108A (Rotax S3304) is generally similar in construction to that described in the main chapter, but has a separate shunt field input connection to give increased starting torque. The internal connections are shown in fig. 1. When used

in conjunction with a control panel, Type 26 (Rotax U1504), it will give an output of 115-volts, 400 c/s, single-phase a.c. from a 25-28 volts d.c. input, supplying either (a) 770W at a lagging power factor of between 1.0 and 0.84, or (b) 650W at a leading power

RESTRICTED

factor of between 1.0 and 0.95. It is used with a starting switch, Type 1A, No. 5 (Rotax U2005/1), and must not be started up on load.

2. Natural cooling is employed up to 35,000 ft., and blast cooling for altitudes above that and up to 55,000 ft. The direction of cooling air is from d.c. to a.c., and the connections may be reversed according to which type of cooling is to be employed; for natural cooling a gauze inlet and piped outlet are used, but for blast cooling a piped inlet and gauze exhaust. The piped connection may be set in any radial position.

3. A combined suppressor and connection box is mounted on top of the machine. At one end is fitted the 2-pole a.c. output socket, and at the other end the 6-pole socket for interconnection to the control panel, two cable gland entries for the d.c. supply leads, and an additional entry for the lead to the shunt field terminal S. This lead is connected to the input side of the starting switch.

4. Four 0.312 in. dia. holes are provided in the mounting feet; their centres are 9.625 in. (axially) by 5.625 in.

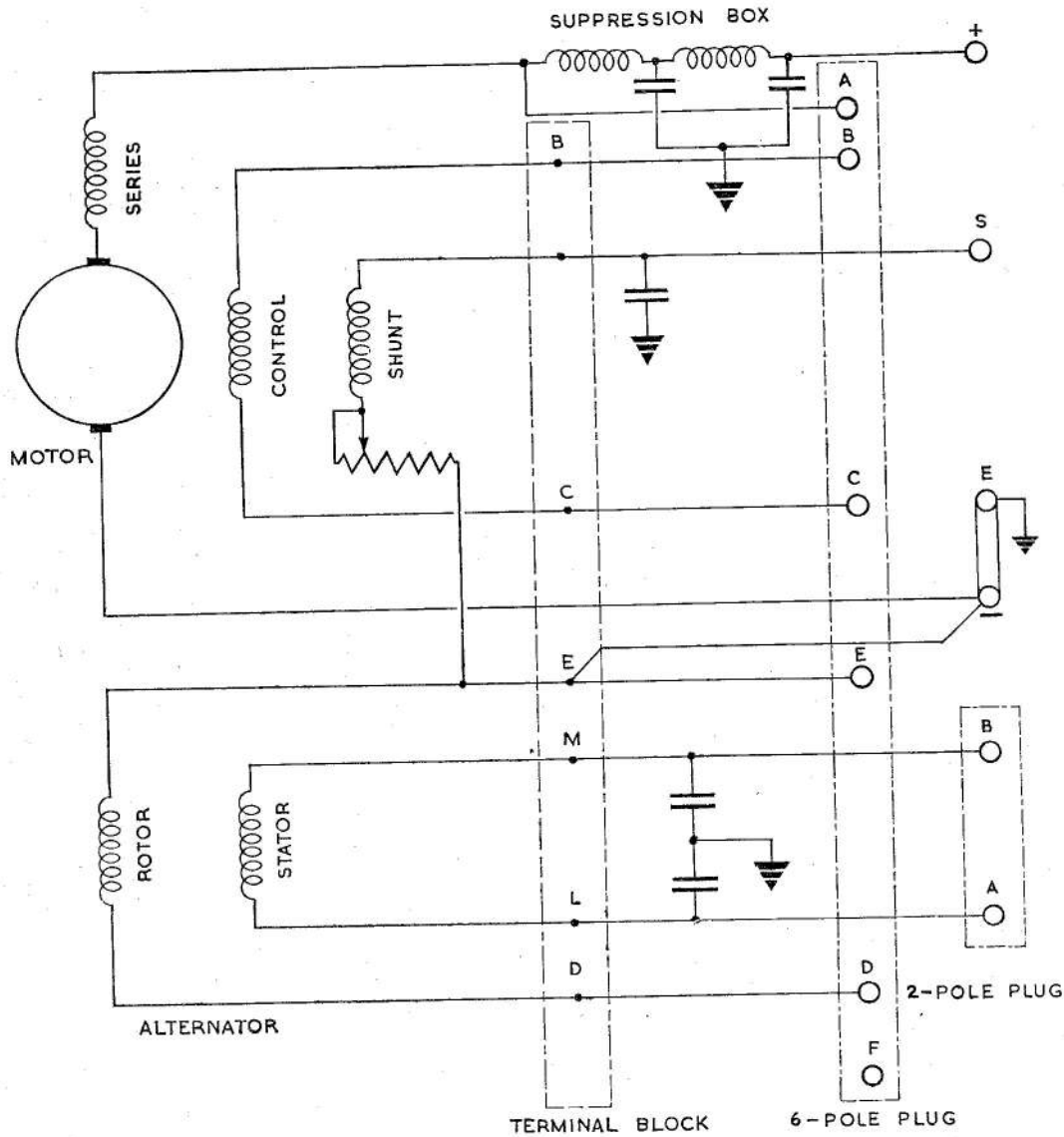

Fig. 1. Diagram of internal connections

RESTRICTED

See AP 113D-0109-16

held 'C'

Appendix 4

ROTARY INVERTER, ROTAX, TYPE S3307

LEADING PARTICULARS

Inverter, Rotax, Type S3307	Ref. No. 5UB/
Input voltage	25-28 volts d.c.
Output—									
Voltage	115V, single-phase a.c.
Frequency	400 c/s
Power (rated)	770W, 1.0-0.84 power factor (lagging) or 650W, 1.0-0.95 power factor (leading)
Input brushes—									
Brush grade	KCEG11
Spring pressure	20-24 oz. (567-680 gm.)
Length when new	0.906 ± 0.010 in.
Minimum permissible length	0.562 in.
Output brushes—									
Brush grade	KCEG11
Spring pressure	4-5 oz. (114-141 gm.)
Length when new	0.697 ± 0.010 in.
Minimum permissible length	0.531 in.
Rating	Continuous
Speed	8000 r.p.m.
Rotation (viewed on commutator end)	Clockwise
Cooling	Fan
Temperature range	-65 deg. C. to +70 deg. C.
Electrical connections—									
Input	Cable gland nut and sleeve
Output	2-pole miniature Mk. 4 socket (CZ49217) (Ref. No. Z560230)
Control panel interconnection	6-pole miniature Mk. 4 socket (CZ49223) (Ref. No. Z560260)
Minimum commutator diameter	1.875 in.
Minimum slip ring diameter	0.75 in.
Overall dimensions—									
Length	16.625 in.
Width	6.375 in.
Height	7.968 in.
Weight	30.5 lb.

RESTRICTED

1. The inverter, Rotax, Type S3307, is generally similar in construction to that described in the main chapter. When used in conjunction with a control panel, Type 26 (Rotax U1504), it will give an output of 115-volts, 400 c/s, single-phase a.c. from a 25-28 volt d.c. input, supplying either (a) 770W at a lagging power factor of between 1.0 and 0.84, or (b) 650W at a leading power factor of between 1.0 and 0.95. It is used with a starting switch, Type 1A, No. 5 (Rotax U2005/1), and must not be started up on load. The internal connections are as shown in fig. 1.

2. Natural cooling is employed for this machine. Cooling air enters through a

gauze screen at the d.c. end, and leaves through a gauze outlet at the a.c. end. Apart from this one feature, the machine is identical with the inverter, Type 108 (Rotax S3303/1).

3. A combined suppressor and connection box is mounted on top of the machine. At one end is fitted the 2-pole a.c. output socket, and at the other end the 6-pole socket for interconnection with the control panel, and two cable gland entries for the d.c. supply leads.

4. There are four fixing holes 0.312 in. diameter, with centres 9.625 in. (axially) by 5.625 in.

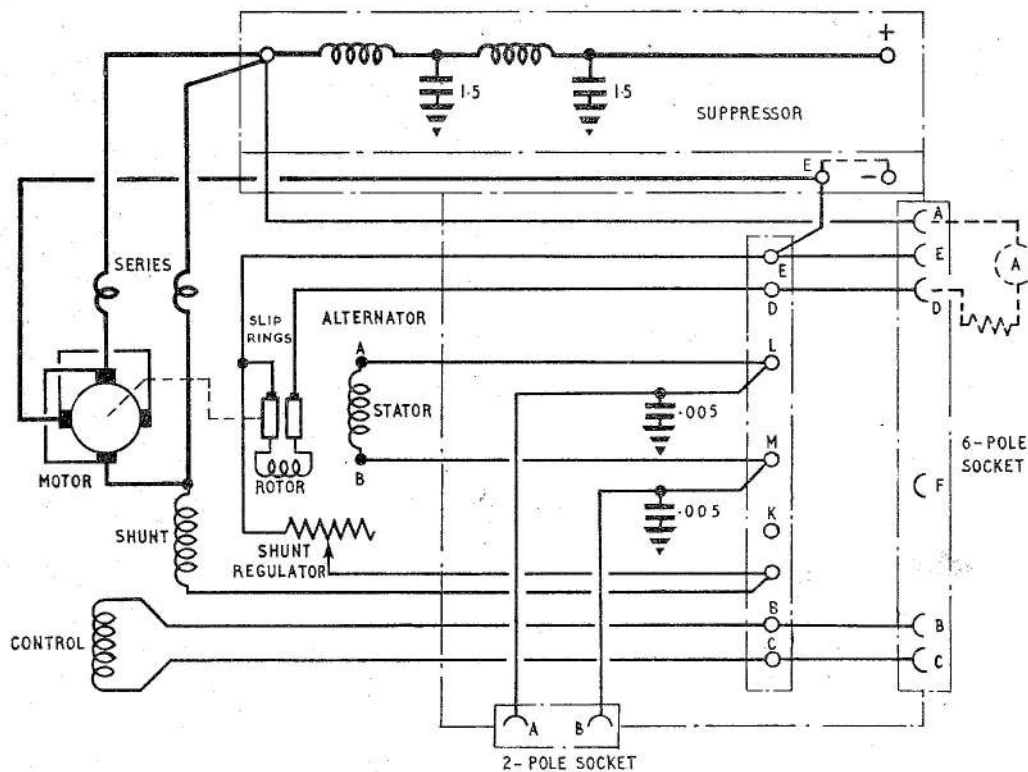

Fig. 1. Diagram of internal connections

RESTRICTED

This file was downloaded
from the RTFM Library.

Link: www.scottbouch.com/rtfm

Please see site for usage terms,
and more aircraft documents.

