

Chapter 2

ROTARY INVERTER, TYPE III

LIST OF CONTENTS

	Para.		Para.
Introduction	1	Servicing	
Description		Brushgear	15
General	4	Commutators and slip rings	18
Blast cooling	5	Bearings	19
Brushgear	6	Final inspection	20
Control box	7	Testing	21
Plug and sockets	8	Governor speed setting	
Inverter unit	9	General	22
Suppressor units	10	To set the value of R_f	25
Governor speed control gear	11	To set the value of R_g	26
Operation	12	Governor inspection	27
Installation	14	Insulation resistance test	28

LIST OF ILLUSTRATIONS

	Fig.		Fig.
General view of inverter with cover removed	1	Installation drawing	4
Sectional view of inverter	2	Simplified circuit diagram of governor speed control	5
Plan view of control box	3	Circuit diagram of inverter and voltage regulator, Type 108	6

LEADING PARTICULARS

Rotary inverter, Type III	Stores Ref. SUB/6307
Inverter speed	8000 r.p.m.
Input voltage and current	25 to 29 volt d.c. 23 amp.
Output	115-volt 3-phase a.c. 0.8 p.f. 400 c.p.s. 250 watts
Rating with blast cooling	Continuous
Brush grade carbon	Nobrac E1 or Morgan E.G.14
Brush spring pressures	
Governor brushes	3.7 oz. to 5.2 oz.
Slip ring a.c. brushes	2.5 oz. to 3.5 oz.
Motor d.c. brushes	8 oz. to 12 oz.
Length of new brush	
Governor brushes	0.68 in.
Slip ring a.c. brushes	0.68 in.
Motor d.c. brushes	0.68 in.
Minimum brush length	
Governor brushes	0.37 in.
Slip ring a.c. brushes	0.37 in.
Governor brushes	0.37 in.
Rotation (viewed from Commutator end)	Clockwise
Winding resistance values	
Motor shunt field	3.0 ohms
Stator winding	5.2 ohms (line to line)
Pre-set resistance R_f	Zero to 2 ohms
Governor resistance	10 ohms (approx.)
Starting resistance	0.2 ohms
Weight of inverter unit	21.8 lb.

(A.L.5, Mar. 58)

F.S./1

B (AL5)

RESTRICTED

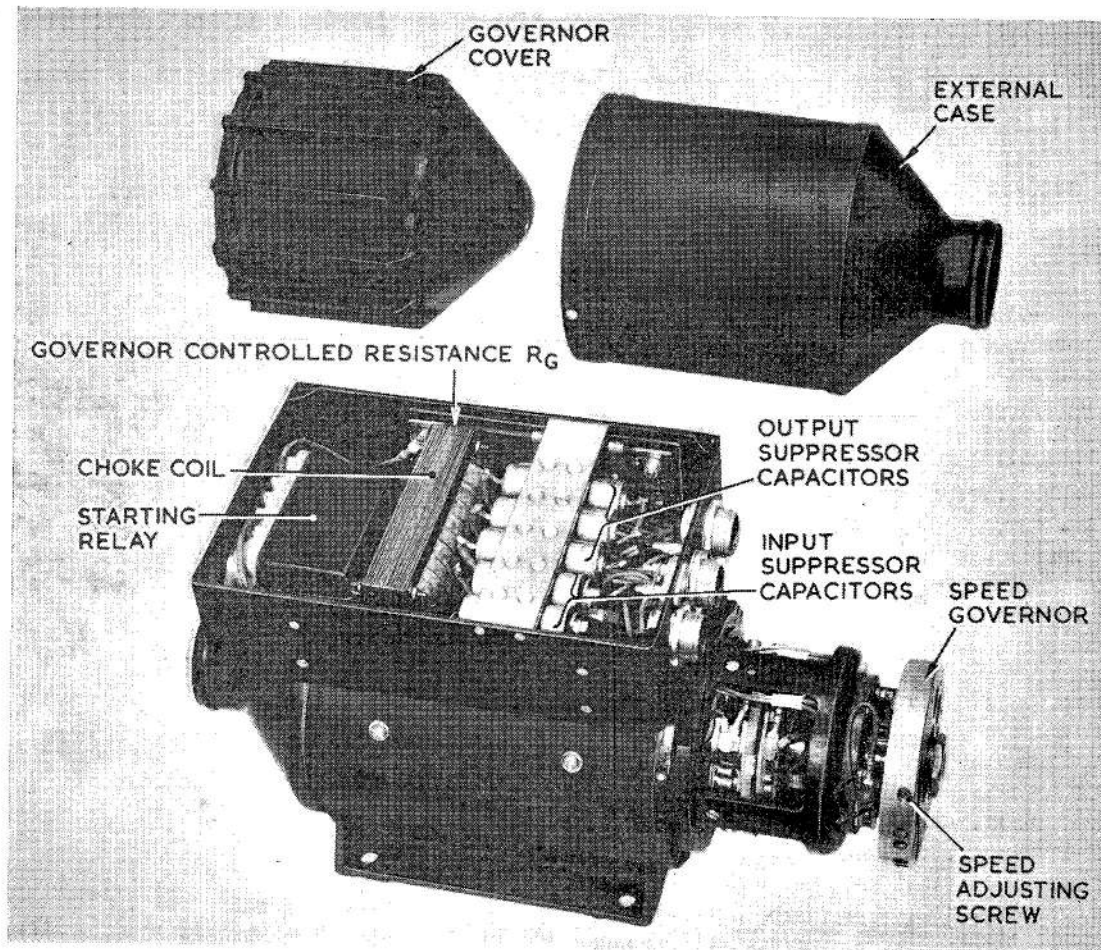

Fig. 1. General view of inverter with cover removed

Introduction

1. The Rotary Inverter, Type 111 is designed to provide an output of 250 watts, at 115-volt, three-phase a.c., with a power factor of 0.8 lagging and a frequency of 400 cycles per second, the speed being 8000 r.p.m. The input current is 23 amperes at 25 to 29 volt d.c.

2. The inverter, which, in this instance is used to provide a power supply for navigational instruments, is designed to operate in conjunction with Newton's carbon pile voltage regulator, Type 108, details of which are contained in Sect. 1 of this publication. This regulator is a separate unit, the connecting leads to the inverter being of specially screened cable.

3. The machine is capable of operation from a fully insulated system, but provision is made by means of a suitable, easily accessible link for earthing internally its negative side.

DESCRIPTION

General

4. The inverter comprises a 25- to 29-volt d.c., four pole, compound wound motor and a 115-volt, three-phase a.c., 400 cycle per second generator. The d.c. armature input windings and the a.c. generator exciting windings are carried on the same shaft and rotate within the influence of the shunt and series d.c. windings and the stator a.c. windings respectively.

RESTRICTED

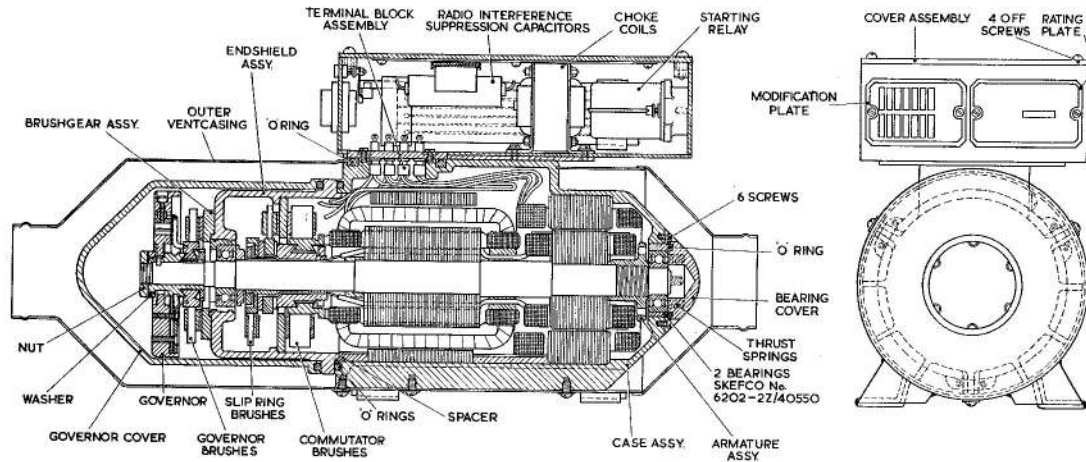

Fig. 2. Sectional view of inverter

Blast cooling

5. The machine is of a totally enclosed design, the inner case being hermetically sealed with 'O' rings. Blast cooling is effected by the introduction of an outer vent casing,

whereby air is drawn through the air inlet, between the inner and outer casings of the machine and through the air outlet, thus keeping the operating temperature within pre-determined limits.

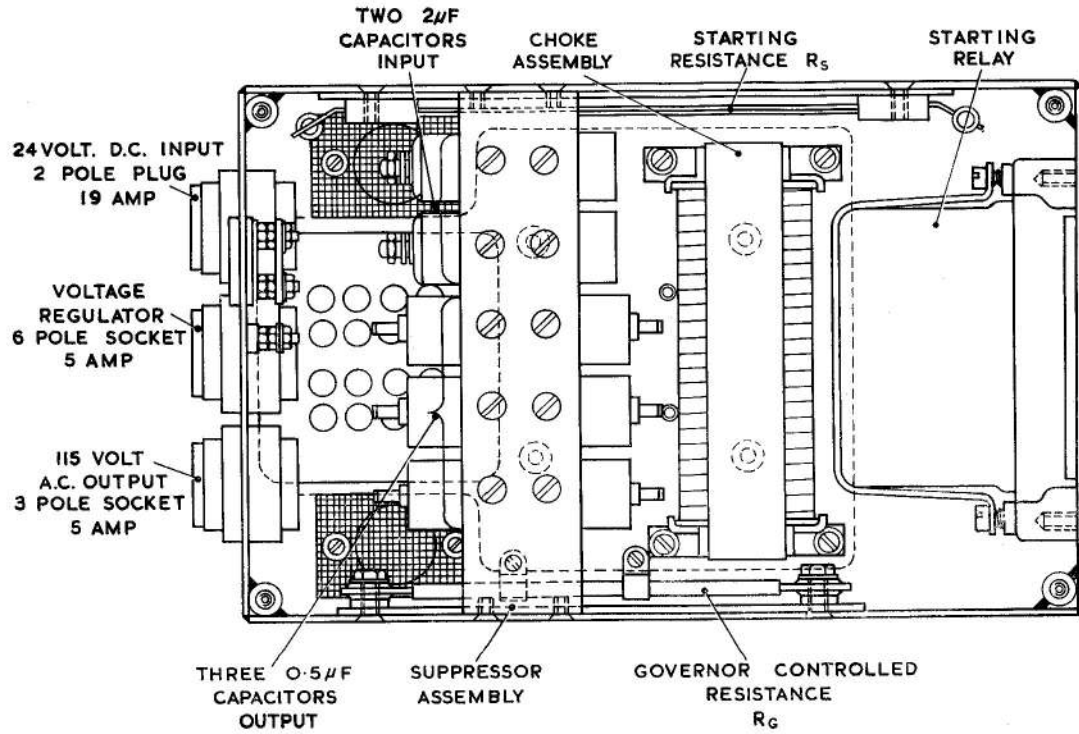

Fig. 3. Plan view of control box

(A.L.5, Mar. 58)

Brushgear

6. The brushgear for the d.c. input, a.c. output and the governor speed control gear is carried on the end shield, providing easy access to the different brush sets, through openings in the end shield, by first removing the outer vent casing and the governor cover.

Control box

7. A control box, which is secured to the inverter by four 2 B.A. by $\frac{3}{8}$ in. screws, carries the control gear, which comprises a starting relay, starting resistance, (shunt field resistance and choke coil in series), governor resistance, earthing link and radio interference suppression capacitors. Two Breeze sockets and one Breeze plug are provided for the electrical connections.

Plug and sockets

8. A 2-pole, 19 amp. Breeze plug is provided for the 25 to 29 volt d.c. input, a 3-pole, 5 amp. Breeze socket for the 115 volt, three phase a.c. output load, and a 6-pole, 5 amp. Breeze socket for the specially screened cable connection to the voltage regulator, Type 108.

Inverter unit

9. The armature shaft, which carries the d.c. and a.c. field windings and governor

speed control assemblies, is supported in ball bearings, located in the inverter case and end shield respectively.

Suppressor units

10. Two radio interference suppressor units are located in the control box. The d.c. input suppressor unit comprises two $2 \mu\text{F}$ capacitors and the a.c. output suppressor unit three $0.5 \mu\text{F}$ capacitors.

Governor speed control gear

11. The governor speed control gear, which is carried on the armature shaft and rotates with it, comprises a six segment commutator, with two brushes and a centrifugal contact switch. Six resistances, four of 35 ohms each and two of 70 ohms each, are connected across the governor commutator segments (*fig. 5*). These resistances tend to stabilize the effect of the reversal of current on each rotation of the armature. A pre-set, field resistance (R_f) is in series with the governor resistance (R_g) and the shunt field, when the governor switch is open. When the governor switch is closed the governor resistance is by-passed, the circuit being through the field resistance and choke coil, across the governor switch, through the shunt field to negative. The values of the different resistances are shown in Leading Particulars.

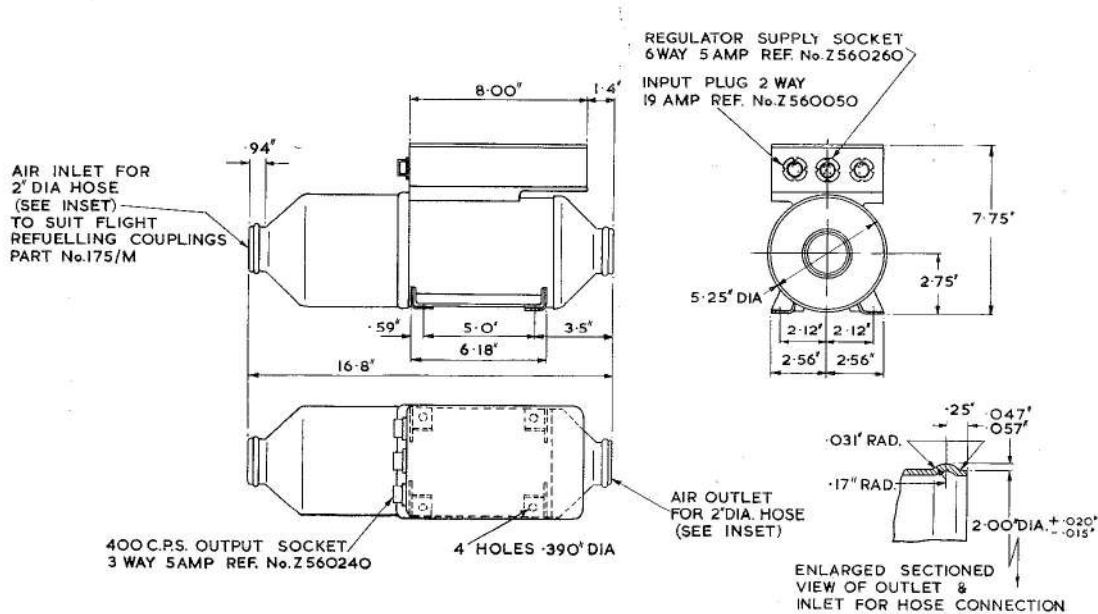

Fig. 4. Installation drawing

RESTRICTED

OPERATION

12. When the inverter is put into operation, there is a circuit through the starting resistance, series field and armature to negative, after a short delay the starting relay is energized, being shunted across the armature. There is also a parallel circuit through the pre-set field resistance and choke coil, governor resistance and shunt field to negative. As the d.c. motor of the inverter speeds up, the starting relay contacts close, cutting out the starting resistance (R_s). Should the motor speed increase above that for which it was designed, centrifugal action closes the governor switch, short-circuiting the governor resistance, thereby strengthening the shunt field and the motor speed decreases. Should the motor speed fall below that for which it was designed, centrifugal action opens the governor switch, which automatically inserts a governor resistance in series with the pre-set field resistance, choke coil and shunt field. The resultant effective shunt field is therefore weakened and the motor speed increases.

13. The voltage of the inverter is controlled by a Newton's carbon pile regulator, Type 108, which is in series with the generator field.

INSTALLATION

14. Four feet, or mounting brackets, which are welded to the inverter, are for securing the machine in its position in the aircraft, and are held down by four $\frac{3}{8}$ in. screws or bolts. To allow for maximum efficiency of the centrifugal governor speed control gear, the inverter should be installed, in a horizontal position. Dimensions of the inverter are shown (*fig. 4*).

SERVICING**Brushgear**

15. The inverter will require little servicing other than attention to the d.c. and a.c. brushgear and the governor speed control brushgear.

16. The d.c. and a.c. brushgear and the governor speed control brushgear are all accessible from the governor end of the machine (*fig. 1*). By removing the blast cooling cover and the governor cover, all brushes are accessible through openings in the end shield.

17. Particular attention must be given to the minimum brush length (see Leading Particulars), and the brushes must be renewed if not sufficiently greater than the minimum permissible. This will entail removing the inverter from the aircraft, in order to fit the new brushes. Carbon dust deposits must be blown out, using dry compressed air. The brushes must slide easily in their boxes, and once bedded, and subsequently removed for examination, must be replaced in their original positions. Measured brush spring pressures and minimum brush lengths must agree with those as given in Leading Particulars. All brush-gear connections must be tight and free from foreign matter, or corrosion.

Commutator and slip rings

18. The d.c. and governor commutators and a.c. slip rings must be examined for signs of wear. The commutator wear may be expected to be 0.015 in. per 1000 hours, and should be re-skimmed when the wear amounts to 0.03 in. (radial), when brush replacements should be made as necessary. New brush lengths are given in Leading Particulars.

Bearings

19. The two ball bearings in which the armature rotates are normally packed with XG-275 by the manufacturers and should require very little attention.

Final inspection

20. Examine 'O' rings for signs of deterioration, and finally, when replacing covers, having ascertained that all internal connections are tight, ensure that all external inverter and installation connections are secure.

Testing

21. At ground level testing, where there is no cooling air, the maximum period of running should be 30 minutes every two hours. Air blast cooling at 50 cubic feet per minute, if available at ground level, will allow the machine to be run continuously if desirable.

GOVERNOR SPEED SETTING**General**

22. Speed control governors are precision instruments and require care in adjustment and maintenance.

(A.L.5, Mar. 58)

Note . . .

The governor speed setting should not be adjusted except by a qualified technician, if it is not considered desirable to return the machine to the manufacturers for adjustment, in the event of the original setting having been altered for any reason.

23. The speed is set to give 400 cycles per second a.c. output, that is a speed of 8,000 r.p.m. The speed is adjusted by a slotted fine thread screw situated on the periphery of the governor and seen (fig. 1).

24. The speed and frequency are held stable notwithstanding load changes of from $\frac{1}{5}$ to full load and 25 to 29 volt d.c. input by the operation of the governor. A simple test to verify that the machine is operating under the control of the governor, apart from watching the frequency meter, as load and input volts are changed, is to connect a telephone and capacitor in series across the resistance R_g , when a crackling noise is to be heard. The values of the resistances of the governor control circuit are not to be altered in any normal circumstances (para. 11). If for any reason they have to be reset, the two following limiting conditions enable the correct values of R_f and R_g to be made.

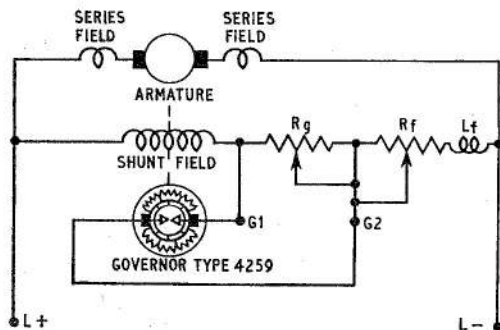

Fig. 5. Simplified circuit diagram of governor speed control

To set the value of R_f

25. Set R_g to 6 ohms, set the input volts to 29, the load to 50 watts and the temperature to its maximum value. Adjust R_f , after half an hour run, to the value where the noise in the telephone receiver connected across the resistance R_g changes from a crackle to a burr noise. This is the value of R_f .

To set the value of R_g

26. Operate the machine at minimum, or, room temperature, 25 volt d.c. input, with 250 watts load. Adjust R_g until the margin is reached where the crackling noise begins. This is the value of R_g .

Governor inspection

27. At regular servicing periods the governor contacts should be cleaned by burnishing the surface, preferable with a diamond loaded burnisher. The contact surfaces should be left substantially smooth and well finished, removing the minimum of contact material. After cleaning of contacts the frequency and speed should be checked as referred to in preceding paragraphs.

Note . . .

It should be noted that the rotating member is dynamically balanced and in maintenance no modification should be made to the distribution of the mass without re-balancing.

Insulation resistance test

28. Using a 250 volt insulation resistance tester, measure the insulation resistance between all live parts and earth; this value must not be less than 2 megohms.

29. After the machine has been installed in the aircraft the insulation resistance value must not be less than 50,000 ohms.

RESTRICTED

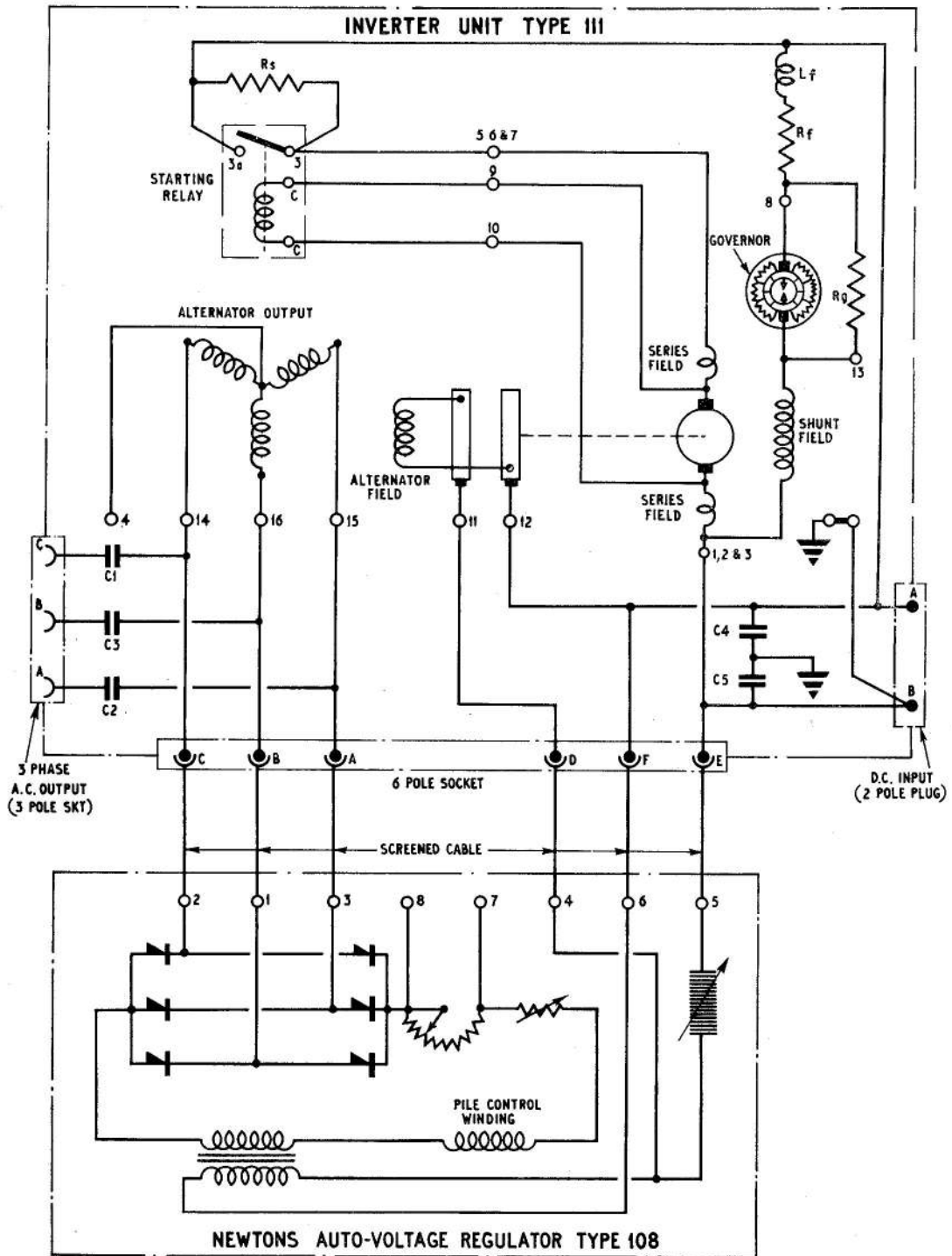

Fig. 6. Circuit diagram of inverter and voltage regulator, Type 108

(A.L.5, Mar. 58)

RESTRICTED

This file was downloaded from the RTFM Library.

Link: www.scottbouch.com/rtfm

Please see site for usage terms, and more aircraft documents.

