

## Chapter 22

## ROTARY INVERTER, TYPE 304

## LIST OF CONTENTS

	Para.		Para.
Introduction ...	1	Operation ...	10
Description		Installation ...	11
General ...	3	Servicing	
Inverter unit ...	6	Brush gear ...	13
Brush gear ...	7	Commutator, slip rings and bearings ...	15
Cooling ...	8	Insulation resistance test ...	17
Suppressor unit ...	9	General ...	18

## LIST OF ILLUSTRATIONS

	Fig.		Fig.
Sectional views of rotary inverter, Type 304 ...	1	Circuit diagram of rotary inverter, Type 304 with carbon pile regulator, Type 69 ...	3
Circuit diagram of rotary inverter, Type 304 ...	2		

## LEADING PARTICULARS

<b>Rotary inverter, Type 304</b> ...	Stores Ref. 5UB/5956
Input ...	18-volt d.c.; 3000 r.p.m.
Output ...	230-volt, 50 cycles; single-phase a.c.; 0.81 amp.
Apparent power ...	187 volt amps.
True power ...	150 watt.
Power factor ...	0.8 lag.
Rating ...	Continuous
Rotation (view at commutator end) ...	Anti-clockwise
<b>Electrical connections</b>	
Input ...	Mk. 4 2-pole plug I.S. No. Z560216
Output ...	Mk. 4 3-pole plug I.S. No. Z560050
<b>Brush grade</b>	
d.c. input ...	H.A.M./C.M.3
a.c. output ...	H.A.M./H.M.6
<b>Brush spring pressure</b>	
d.c. input ...	18 oz.
a.c. output ...	2½ oz.
<b>Minimum brush length</b>	
d.c. input ...	0.375 in.
a.c. output ...	0.375 in.
<b>Minimum commutator diameter</b> ...	1.6 in.
<b>Minimum slip ring diameter</b> ...	1.6 in.
<b>Weight</b> ...	25 lb.
<b>Inverter dimensions</b>	
length ...	12.875 in.
breadth ...	7.625 in.
height ...	7.5625 in.
<b>Capacitors 2 micro-farad</b> ...	Stores Ref. 5CY/3149 (2 off)
<b>Capacitors 0.5 micro-farad</b> ...	ST and C Type 335/64A-1 (2 off)

RESTRICTED

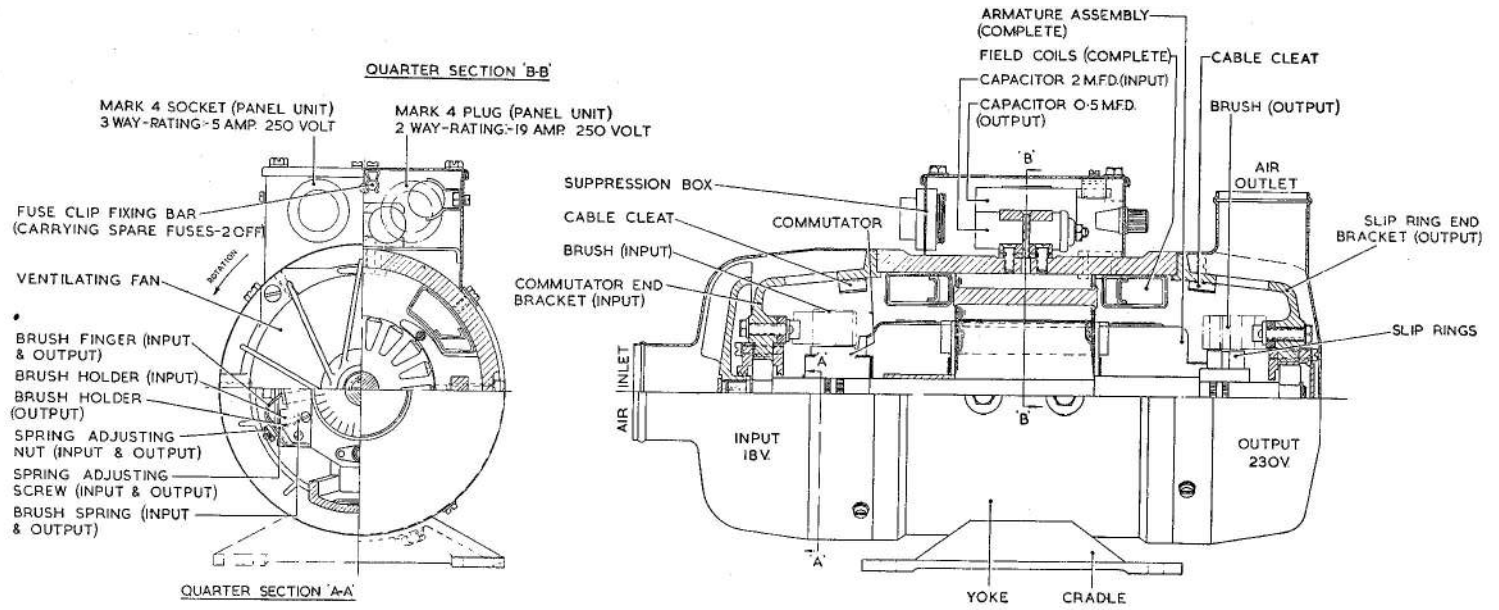

Fig. 1. Sectional view of rotary inverter, Type 304

**Introduction**

1. The rotary inverter Type 304 (fig. 1) is designed to give an output of 150 watts at 0.8 lag, 230-volt, a.c., single-phase at 50 cycles per second, and a nominal current of 0.81 amps, with an input of 18-volt d.c.

2. The machine is designed to operate in conjunction with series regulator Type 69.

**DESCRIPTION**

**General**

3. The inverter comprises a 18-volt d.c., two pole, compound wound motor, driving a 230 volt a.c., 50 cycles per second generator. Both d.c. input and a.c. output windings are carried on a common shaft; the a.c. windings being superimposed on the d.c. windings of the armature.

4. A 2-pole, Mk. 4, coarse thread plug provides the electrical connection for the d.c. motor input, and a 3-pole, Mk. 4, coarse thread socket for the generated output of the inverter.

5. The motor shunt and series coils are wound on two magnet poles, secured to a common yoke, between which the armature, carrying both a.c. and d.c. windings, rotates.

**Inverter unit**

6. The armature shaft carrying the commutator and slip ring assemblies, is held in two Hoffman Type NSF 112 ball bearings; one in each of the commutator and slip ring end frames respectively. Each end frame is secured to the yoke by four 2 B.A.  $\times$   $\frac{3}{4}$  in. ch. hd. screws and shakeproof washers respectively. The air inlet and air outlet covers are each secured to their respective end frames by four 4 B.A.  $\times$   $\frac{1}{4}$  in. ch. hd. screws and shakeproof washers.

**Brush gear**

7. The a.c. and d.c. brush gears are each held to their respective commutator and slip ring end frames by four 2 B.A.  $\times$  1 in. bolts and plain steel washers. Brush grades, brush spring pressures, and minimum brush lengths are listed in leading particulars. There are two d.c. carbon brushes  $\frac{3}{4}$  in.  $\times$   $\frac{3}{8}$  in.  $\times$   $\frac{11}{16}$  in. for the input end, which make contact with the commutator, and 2 carbon brushes  $\frac{3}{8}$  in.  $\times$   $\frac{11}{16}$  in. for the output end, which bear on slip rings.

**Cooling**

8. Cooling of the inverter is effected by a ventilating fan which is keyed to the commutator, or input end of the armature shaft. With the rotation of the armature, air is drawn by the fan, via the air inlet duct, or cover, which encloses the commutator end frame, passes around the armature windings and fixed coils, and is finally expelled through the air outlet duct, or cover, which encloses the slip ring end frame. The air outlet duct can be moved radially, with respect to the machine, in any one of four positions 90 degrees apart, by removing the screws and washers, which hold it to the slip ring end frame, and turning right or left, as required, finally replacing the screws and washers. Air pipe unions, connected to the air inlet and air outlet ducts, enable the machine to draw its air from another source free from petrol vapour if necessary.

**Suppressor unit**

9. A suppressor box is mounted on the top of the inverter yoke, and contains the suppressor unit, which comprises two 2 micro-farad capacitors, and two 0.5 micro-farad capacitors, the former being in the input circuit, and the latter in the output circuit of the inverter. Two 1 amp fuses found in the box, are protection for the output load, whilst two spare fuses are secured to the underside of the suppressor box cover.

**OPERATION**

10. The current is supplied at 18 volt d.c. (nominal) to the motor, via the series regulator Type 69. The input voltage to the series regulator may vary over the range 21.6

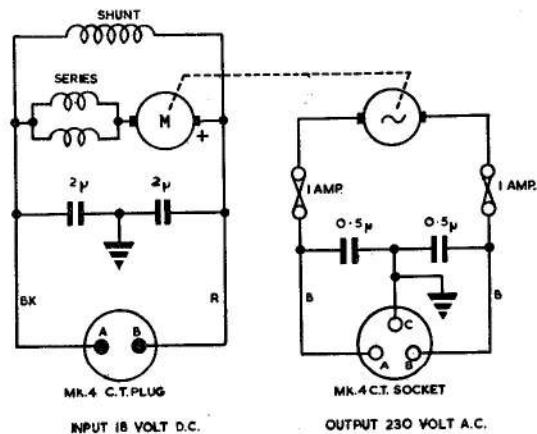

Fig. 2. Circuit diagram of rotary inverter, Type 304

(A.L.I, Sep. 57)

volts to 29 volts (no load to full load). The operating coil of the series regulator is connected via associated rectifiers, and ballast resistors across the a.c. output. The carbon pile of the series regulator is connected in the positive line of the d.c. input. Variation of output voltage, due to change in input voltage, or load variation (no load to full load), causes a change in carbon pile resistance, such that the input voltage at the inverter terminals is brought to such a value to restore the output voltage to 230-volt, a.c.  $\pm 2\frac{1}{2}$  per cent. with the frequency 50 cycles per second  $\pm 10$  per cent. at the rated input voltage of 18 volts d.c.

#### INSTALLATION

11. The inverter is secured at the yoke to a cradle, or mounting bracket, by 2 locking plates and four 0 B.A. hex. hd.  $\times \frac{1}{2}$  in. screws. Four slotted holes  $\frac{3}{16}$  in. wide are provided in the cradle for securing the inverter to the aircraft. The slots allow a small degree of lateral movement to obtain exact position for final installation.

12. Provision for adequate circulation of air, in and around the unit must be made before final installation.

#### SERVICING

##### Brush gear

13. The inverter will require little servicing other than attention to the a.c. and d.c. brush gear.

14. The a.c. and d.c. brush gears become easily accessible by removing the air inlet and air outlet ducts, thus exposing the commutator and slip ring endframes, which carry the brush gear assemblies. Particular attention must be given to the minimum brush length (see leading particulars), and the brushes must be renewed, if not sufficiently greater than the

minimum permissible. This will entail removing the inverter from the aircraft, in order to bed the brushes to the contour of the commutator efficiently. Carbon dust deposits must be blown away, using dry compressed air. The brushes must slide easily in their boxes, and once, bedded, and subsequently removed for examination, must be replaced in their original positions. Replacing them incorrectly by turning them  $180^\circ$ , may effect the future efficiency of the machine. Brush spring pressures when measured with a spring balance, must be as shown in leading particulars. For d.c. brushes, use a spring balance Stores Ref. 1H/59 and for the a.c. brushes, a spring balance Stores Ref. 1H/97. All brush gear connections must be tight and free from corrosion.

##### Commutator, slip rings and bearings

15. The commutator and slip rings must be examined for signs of wear. If there is any serious scoring, or burning, then the inverter complete, must be removed for repair.

16. The two ball bearings in which the armature shaft rotates are normally packed with grease, through Telecalemite lubricator Type AGS 554, which are fitted on both input and output end brackets. The bearings should require very little attention.

##### Insulation resistance test

17. Using a 250-volts insulation resistance tester, the insulation resistance must not be less than 2 megohms.

##### General

18. The suppressor boss should be examined to ensure that the suppressor unit connections are tight, and free from corrosion. Finally replace suppressor box, and brush gear covers, and ensure that all external nuts, bolts and screws are properly home.

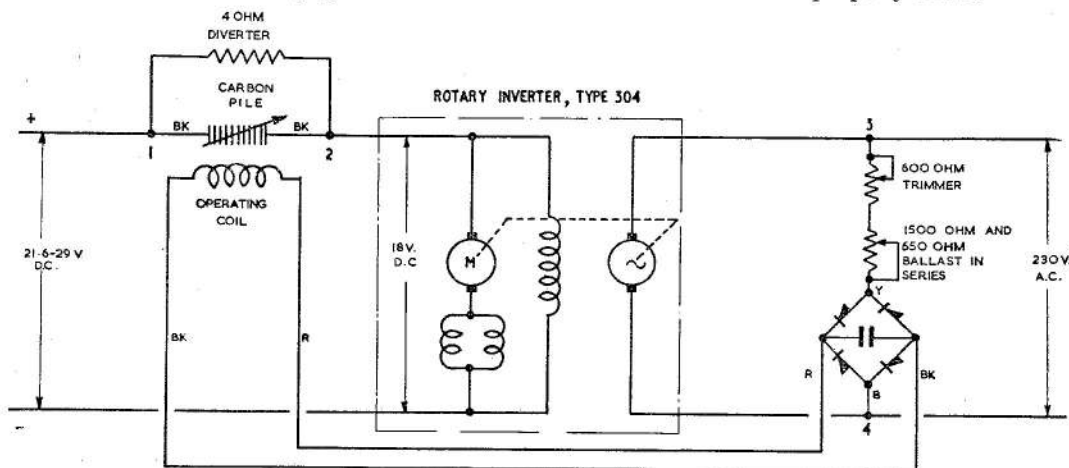

Fig. 3. Circuit diagram of rotary inverter, Type 304, with carbon pile regulator, Type 69

RESTRICTED

This file was downloaded  
from the RTFM Library.  
Link: [www.scottbouch.com/rtfm](http://www.scottbouch.com/rtfm)

Please see site for usage terms,  
and more aircraft documents.

