

Chapter 30

ROTARY INVERTERS, TYPE 117

LIST OF CONTENTS

	<i>Para.</i>		<i>Para.</i>
<i>Introduction</i>	1	<i>Permanent magnet (P.M.) alternator</i>	42
Description		<i>Armature and commutator end (C.E.)</i>	
<i>General</i>	2	<i>housing</i>	44
<i>Motor alternator</i>	3	<i>Input (d.c.) brushgear</i>	46
<i>Control box</i>	11	<i>Slipring end (S.E.) housing</i>	47
Operation		<i>Output (a.c.) brushgear</i>	49
<i>Starting</i>	15	<i>Contactors</i>	50
<i>Voltage control</i>	16	Cleaning and inspection	51
<i>Frequency control</i>	18	Assembling	
<i>Protection</i>	21	<i>Adjustment of brush forces</i>	53
<i>Cooling</i>	22	<i>Slipring end (S.E.) housing</i>	57
Installation		<i>Commutator end housing and arma-</i>	
<i>Servicing</i>	26	<i>ture</i>	59
<i>Trimming</i>	27	<i>Brushes</i>	62
<i>Brushgear</i>	28	<i>Frequency regulator (P.N.) alternator</i>	64
<i>Bearings</i>	29	<i>Freedom of armature</i>	65
<i>Contactors</i>	30	<i>Contactors</i>	67
<i>Armature</i>	31	<i>Covers</i>	68
<i>Field and magnet assembly</i>	35	Testing	
<i>Covers</i>	36	<i>General</i>	71
<i>Carbon pile regulator</i>	37	<i>Test equipment</i>	72
Dismantling		<i>Starting and brush bedding</i>	73
<i>Covers</i>	38	<i>Set commutation</i>	76
<i>Brushes</i>	41	<i>Performance test</i>	79

LIST OF TABLES

	<i>Table</i>
<i>Fault-finding chart</i>	1

LIST OF ILLUSTRATIONS

	<i>Fig.</i>		<i>Fig.</i>
<i>General view</i>	1	<i>Exploded view of inner control box</i>	
<i>Exploded view of motor alternator</i> ...	2	<i>compartments</i>	5
<i>Exploded view of end cover and trans-</i>		<i>Circuit diagram</i>	6
<i>istor assembly</i>	3	<i>Exploded view of input brushgear</i> ...	7
<i>Exploded view of outer control box</i>		<i>Exploded view of output brushgear</i>	8
<i>compartment</i>	4	<i>Arrangement of connections to output</i>	
		<i>brushgear</i>	9

RESTRICTED

LEADING PARTICULARS

Inverter, Plessey 502-1-00445	Ref. No. 5WB/7886
Input voltage range	22-28.5V d.c. (20V for 5 mins)
Nominal working voltage	28V d.c.
Output voltage	208V r.m.s. line-to-line 2 phase
	±4 per cent for 22/28.5V d.c. input
	+4 -15 per cent, 20V d.c. input
Output frequency	400 c.p.s. ± 4 per cent
Power rating	500 volt-amperes at 0.8 lagging to
	0.9 leading power factor
Generator windings	Star-connected, available neutral
Time rating	Continuous
Ambient temperature range	-40 to +80 deg. C.
Altitude ceiling	10,000 ft, self-cooled (max. ambient 30 deg. C.)
	or 50,000 ft, blast cooled
Shaft speed	12,000 r.p.m.
Rotation (viewed from input end)	Clockwise
Commutator brushes	P.E.G.14
New length	0.860 in.
Min. length	0.450 in.
Spring tension	21-22.5 oz. with 0.030 in. protruding
	(594-637 gm.)
Slipping brushes	P.E.G.14
New length	0.560 in.
Min. length	0.300 in.
Spring tension	5.5-6.5 oz with 0.093 in. protruding
	(156-183 gm.)
Commutator minimum worn diameter	1.375 in.
may be skimmed to	1.395 in.
Concentricity	0.0005 in. T.I.R.
Maximum recessing of micas	0.030 in. deep
Slipping minimum worn diameter may be skimmed to	1.531 in.
	1.541 in.
Concentricity	0.0005 in.
Input (d.c.) end bearing	Skefco 6201/C2
Fit in journal	0.0003 in. interference to
	0.0002 in. clearance
Fit in housing	Size-to-size to 0.001 in. clearance
Output (a.c.) end bearing	Skefco 6202/C2
Fit on journal	0.0003 in. interference to
	0.0003 in. clearance
Fit in housing	0.0005 in. interference to
	0.0009 in. clearance
Weight	30 lb.

Introduction

1. The type 117 rotary inverter, shown in Fig. 1, provides a regulated and filtered three phase 208V, 400 c/s supply for aircraft electronic instruments when operated from the battery or any other nominal 28V d.c. supply. It is entirely self-contained.

DESCRIPTION

General

2. The machine comprises a motor alter-

nator surmounted by a box containing starting and control equipment and radio interference filters. Voltage is controlled by a carbon pile regulator and frequency by silicon transistor circuitry. A permanent magnet alternator is used as the sensor of frequency variations.

Motor alternator

3. Refer to Fig. 2, the motor alternator consists of a four pole stationary-field alternator with star-connected three

RESTRICTED

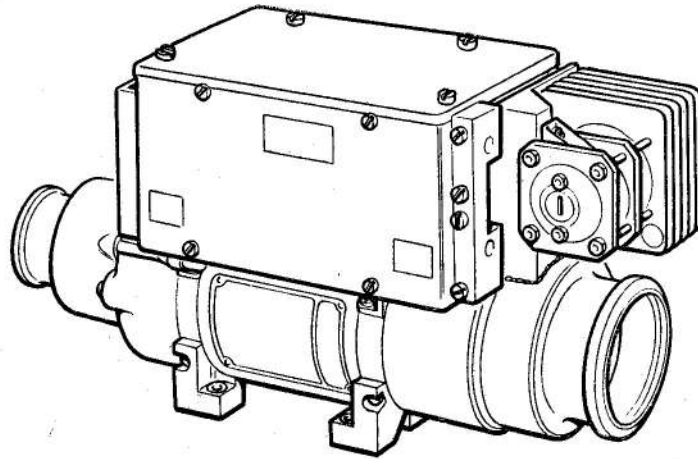

623

Fig. 1. General view

phase rotor, sharing a common housing and shaft with a four-pole compound wound d.c. motor. The alternator phases and the neutral point are made available by means of sliprings and the whole electrical system is isolated from the frame of the machine.

4. Four equi-spaced laminated pole pieces are bolted inside each end of the casing centre section (field magnet assembly) and these carry the field coils for the motor and alternator respectively with the centre section serving as the magnetic yoke. The machine anchorage is by means of two fixing bolts and two locating pegs and the fittings for these, together with the brackets for mounting the control box, are secured to the casing centre section.

5. End housings which carry the input d.c. (motor) and the output (a.c. (alternator) brushgear are bolted at the appropriate ends of the centre section and each is located by a spigot and dowel pin. Both have a moulded-in steel bearing liner to house an armature journal bearing.

6. The input d.c. brushgear comprises four solid brass brush holders secured to an insulating mounting ring, each brush being loaded by a spiral spring held in an adjustable arbor. The assembly can be

rotated in the end housing through an arc, to permit optimum commutation to be obtained for the motor.

7. The output a.c. brushgear consists of four brass half rings, each having two integral brush holders, stacked alternately on each side of a fixed metal mounting plate on ceramic spacing brushes. The brushes in each pair of brush holders subtend an arc of 68 deg. to the corresponding slipring. Spiral springs and triggers mounted on adjustable arbors provide the brush forces. The brushes are accessible in the end housing under two slide-off inspection plates.

8. The motor armature and the alternator rotor are built on the same shaft, the lamination stack for the alternator three phase windings being skewed. The motor commutator and the alternator sliprings are at opposite ends of the shaft and the assembly is supported by grease-lubricated bearings.

9. The magnet of the frequency regulator sensor alternator is carried at the slipring end of the shaft outboard of the bearing. It runs within a wound stator in a housing bolted to the slipring end housing and these parts together form a permanent magnet single phase alternator. The air outlet cover

RESTRICTED

RESTRICTED

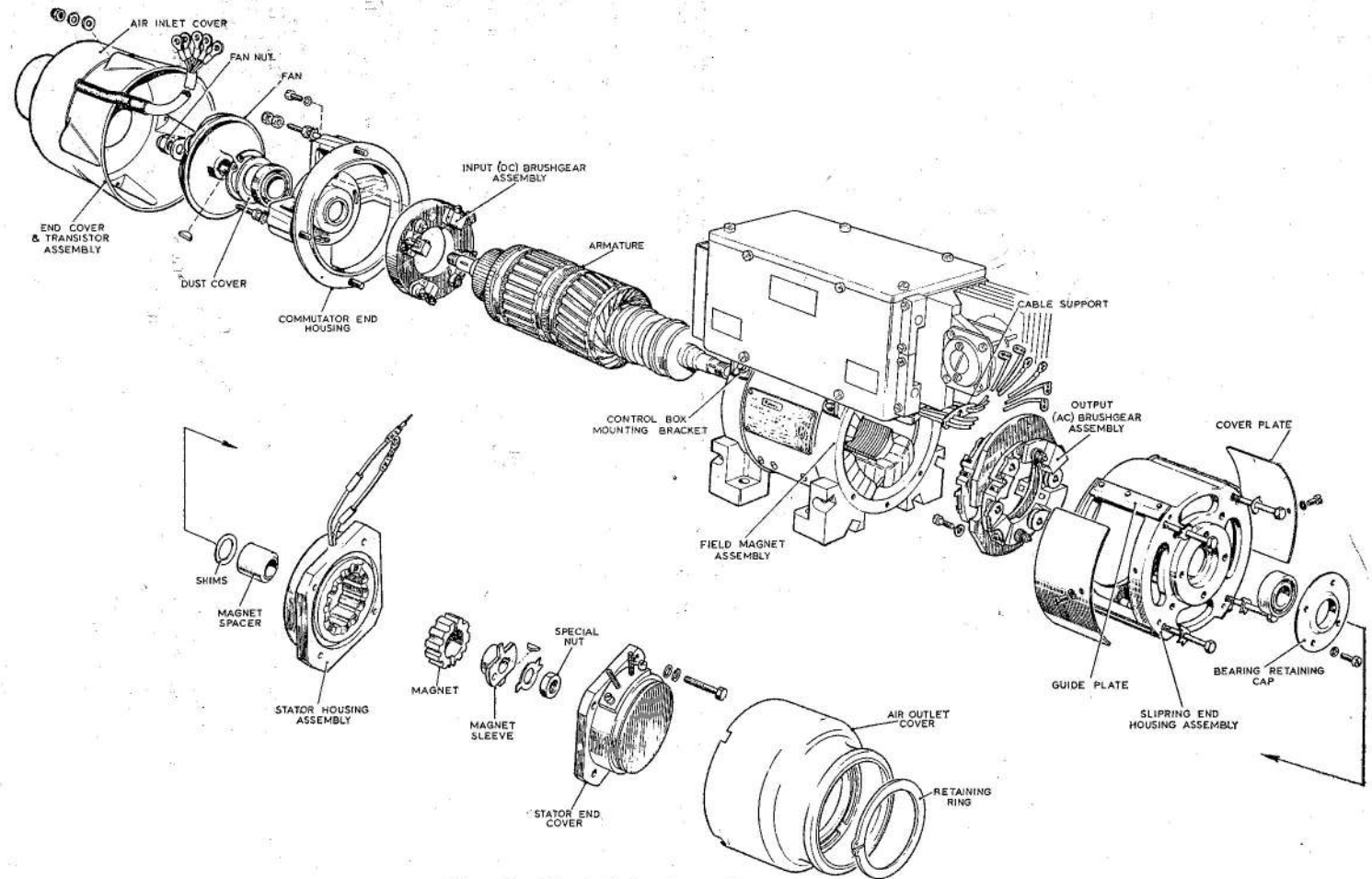

Fig. 2. Exploded view of motor alternator

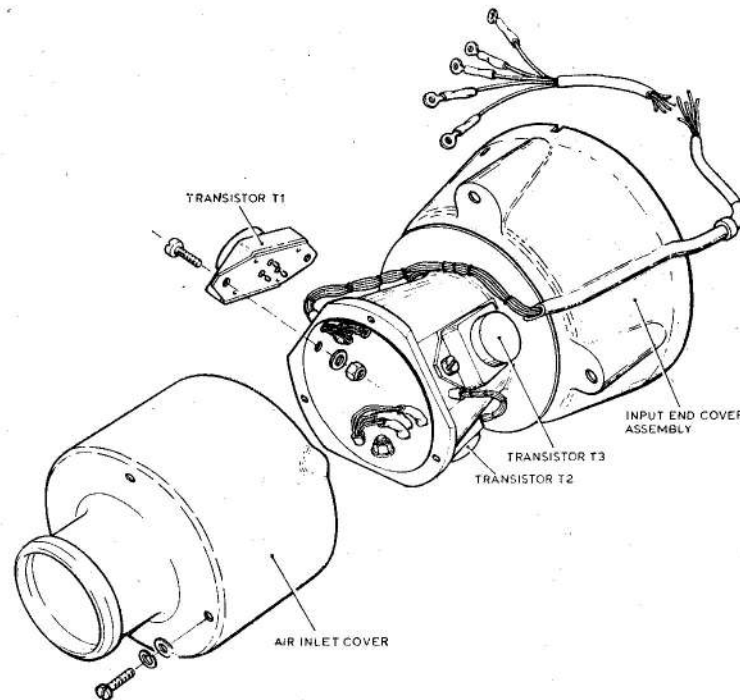

Fig. 3. Exploded view of end cover and transistor assembly

encloses this alternator and is supported by the stator housing.

10. The armature shaft extends beyond the housing at the commutator end and an impeller-type fan is keyed to it. The fan is encased in a close-fitting cowling which is a part of the end cover and also encloses the motor brushgear. The inlet orifice of this cowling serves as a heat sink for three resin-potted transistors mounted on it, which constitute the power stage of the frequency regulator as illustrated in Fig. 3. A second cover fits over the inlet orifice/transistor assembly and this cover reduces to a short pipe, sized and shaped to accept standard aircraft trunking.

Control box

11. The control box is divided into an outer and two inner compartments. It is louvred for ventilation and has a top cover and a removable front plate which covers the outer compartment and gives access to the machine input and output terminal blocks ITB and OTB. The trimmers for

voltage and frequency (R4 and P2) are adjustable through holes in this plate. ITB terminal nuts are threaded $\frac{1}{4}$ in. UNF; those on OTB are 4BA and terminal 2 is not used. An epoxy resin block containing the error detector circuitry for the frequency regulator is mounted externally under a metal shield on one end panel and a pair of nylon blocks, which clamp the supply cables to and from the machine, are screwed to the opposite end panel.

12. The outer compartment, illustrated at Fig. 4, is separated from the inner compartments by a detachable partition. Besides the terminal blocks and the trimmers this compartment holds the input suppression components (RFI filter) consisting of C6, C7 and L3, two silicon diodes MR7 and MR8 which protect the frequency regulator power transistors T1, T2, T3 and the diverter resistor for these transistors (R5).

13. One inner compartment (Fig. 5) holds the starting contactor (CON) and the re-

RESTRICTED

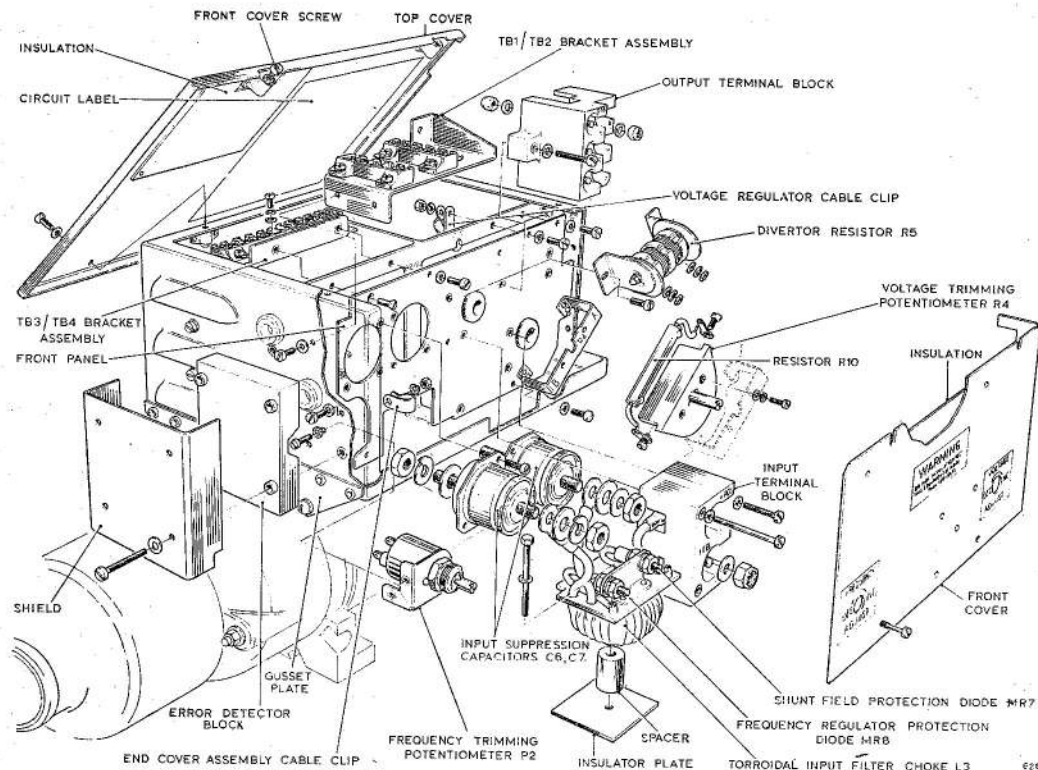

Fig. 4. Exploded view of outer control box compartment

sistor plate assembly on which are mounted the power transistor emitter resistors R6, R7, R8 and R9. The other inner compartment holds the output suppression components (RFI filter) consisting of C2, C3, C4, C5, L1 and L2, the error detector circuit smoothing capacitors (C8, C9 and C10), and the upper mounting assembly to which are mounted; the frequency coarse trimmer P1, the voltage regulator rectifier bridge MR1 to 6 and the padding resistors R1, R2 and R3. Driver transistor T4 is mounted on the wall between the compartments.

14. The Newton carbon pile voltage regulator is mounted on a bracket which is cantilevered on the outside of the control box at the alternator end, adjacent to the cable clamps. Four rubber grommets are fitted to this bracket and they fit over the fixing bushes to serve as anti-vibration mountings.

OPERATION

Starting

15. Refer to Fig. 6. The machine is

started by joining terminal 1 on the output terminal block (OTB) to the +ve of a d.c. supply by means of a suitable switch. This action energizes the starting contactor which then closes to complete the supply to the machine.

Voltage control

16. Control of the machine output voltage is secured by adjusting the alternator field excitation by means of a carbon pile regulator. This excitation is obtained from the d.c. supply via the carbon pile the resistance of which is arranged to be dependant upon the potential in the regulator coil. This coil potential is derived—suitably tailored by resistors R1, 2 and 3 and rectified by full-wave bridge MR1—6 from the machine output. The state of the output voltage is thus reflected into the alternator field by the action of the voltage regulator, which varies the excitation current in such a way as to stabilize the former despite load variations.

17. Trimming potentiometer R4 in series with the regulator coil, provides the means

RESTRICTED

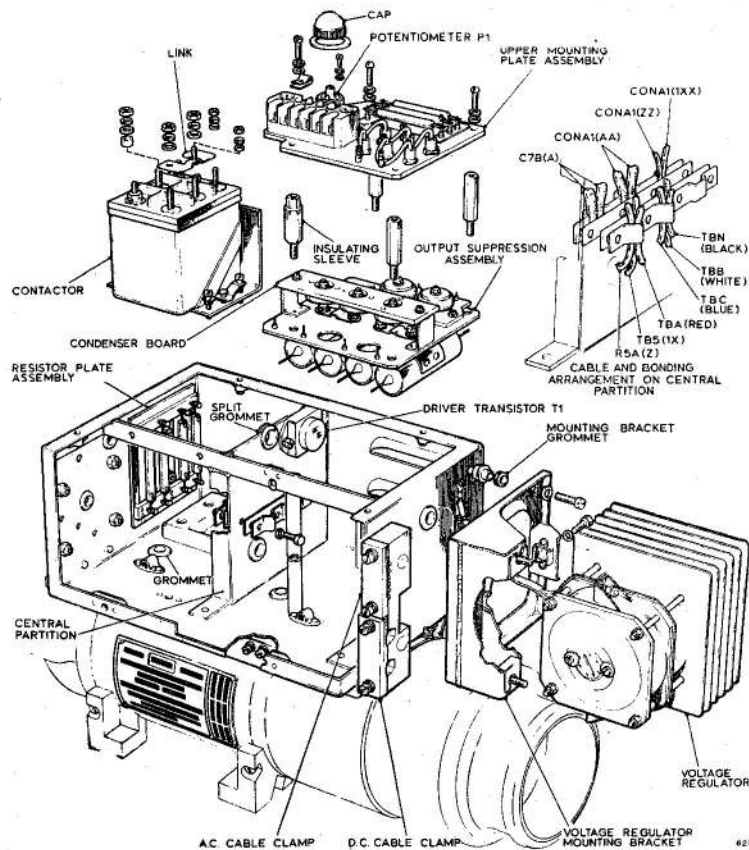

Fig. 5. Exploded view of inner control box compartments

of adjusting a.c. output voltage over an adequate range.

Frequency control

18. Output frequency is directly related to machine speed and is controlled by varying the motor shunt field by means of a transistor series regulator. The input to this regulator is derived from the permanent magnet alternator mounted on the armature shaft. This produces a single phase voltage—directly proportional to machine speed—which is rectified, smoothed, attenuated, to a suitable magnitude by potentiometers P2 and P1, and presented across the input terminals of the error detector unit.

19. The error detector unit is a pair of transistors arranged as an emitter coupled comparator. This comparator measures

the input signal against a reference potential derived from a temperature—compensating pair of Zener diodes and produces a difference signal which varies about a chosen norm—the magnitude of this norm being determined by the circuit parameters. The error signal is amplified by driver transistor T4 and used to vary the conductance of the output stage, direct coupling being employed.

20. The output stage consists of three paralleled power transistors T1, 2, 3 in series with the motor shunt field. An increase in the error signal causes an increase in drive current into their common base and therefore a decrease in their collector-to-emitter resistance. So that the shunt field current will rise and cause the armature speed to slacken. Conversely, a decrease in armature speed will cause a re-

RESTRICTED

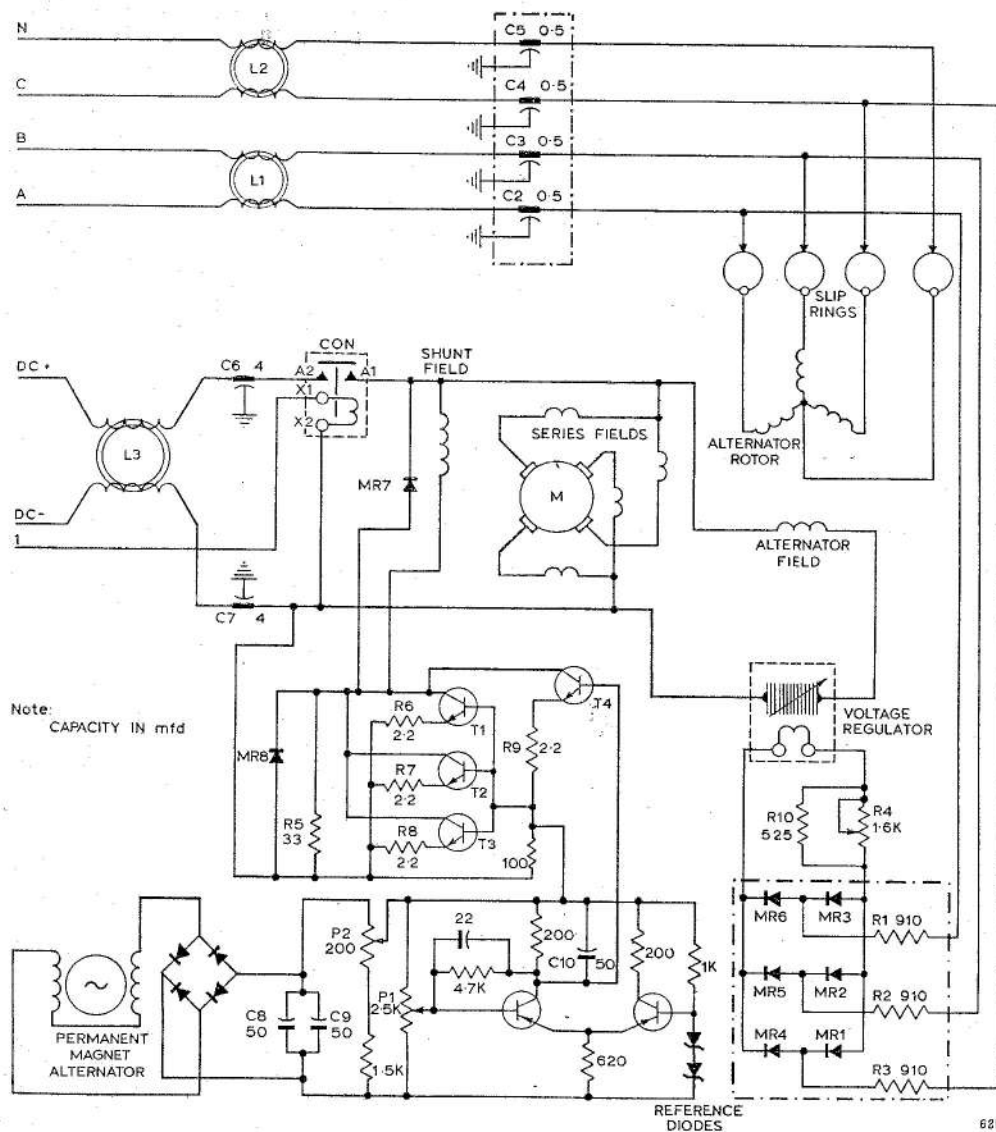

Fig. 6. Circuit diagram

duction in the error signal and the resulting increase in output stage resistance will throttle the shunt field current and the speed will increase. Diverter resistor R5 is connected across the output stage to share the dissipation.

Protection

21. Diode MR7 is connected across the shunt field to protect the output stage by by-passing the inductive surge of reverse polarity which occurs at the instant of switch-off. Likewise diode MR8 is con-

nected across the output stage to catch any negative-going spikes which exceed the line voltage in amplitude.

Cooling

22. The fan on the armature shaft blows air through the inverter from commutator to slipping end. Below 10,000 feet the machine is self-cooled. Above this altitude the fan circulation is augmented by forced air in the input trunking, derived from elsewhere in the aircraft.

RESTRICTED

INSTALLATION

23. Unpack with the minimum of disturbance to permit possible re-use of the materials. Detach bag containing spare plug blocks and return it to stores.

24. Take-off the control box front panel by removing the two lower screws and loosening the two upper ones, then remove the outer halves of the cable clamps. Slide

the inverter on to the mounting tray, open side outwards, engage the two locating pins and secure by bolting the two exposed feet. Join the aircraft trunking to the inlet pipe.

25. Connect - up appropriate aircraft cables to the input and output terminal blocks, secure by means of the cable clamps and replace front panel.

TABLE 1**Fault finding chart**

Fault	Action
Machine fails to start	Check : (1) Supply to input terminal block. (2) brushes are down on commutator (3) armature for open circuit (com. sections) (4) for mechanical stall or seizure (5) contactor coil for open circuit
Excessive noise	Look for : (1) defective bearings (2) high bars on commutator (3) loose banding on armature (4) fouling between fan and end cover
No output	Check : (1) brushes are down on sliprings (2) continuity of voltage regulator pile.
Low voltage output	Check : (1) setting of voltage trimmer (2) adjustment of voltage regulator
Fluctuating voltage output	Check for : (1) low brush forces : brushes 'hanging up' (2) burnt sliprings (3) faulty voltage regulator
Missing/unbalanced phases	Check for cracked or 'hung up' slipring brushes
Frequency too low	Check (1) input voltage low (2) output short circuited or overloaded (3) setting of frequency trimmer
Frequency too high	Check : (1) setting of frequency trimmer.

If the actions described in this table fail to clear the fault, return the machine to base.

RESTRICTED

SERVICING

26. The instructions in this Chapter apply to servicing performed:—

- (a) in accordance with the relevant Servicing Schedule.
- (b) because of unsatisfactory performance

Compatible fault finding instructions are given in Table 1. Refer to para. 38 to 50 for dismantling instructions.

Trimming

27. If the frequency and/or voltage are found to be outside the limits quoted in Leading Particulars, trim back to nominal performance figures using the controls provided, with the machine operating on normal supply and load.

Brushgear

28. Fit a new set of brushes at each service period and compare the brush forces with the values quoted in Leading Particulars. Re-set any brush force found to be outside limits, changing the spring if the correct value cannot be secured. Instructions for fitting and bedding replacement brushes and for re-setting brush forces are given later in this Chapter.

Bearings

29. Lubricate bearings and/or fit replacement at the intervals specified in the relevant Servicing Schedule, maintaining the limitations on fits set out in Leading Particulars. To re-lubricate, first wash the bearing in clean white spirit or lead-free fuel and blow dry without rotating. Pack one third full with XG-275 grease and rotate by hand until the distribution is even. Instructions for gaining access to the bearings are given later in this Chapter.

Contactors

30. Terminals X1 and X2 are connected to the coil; the contacts are brought out to terminals A1 and A2. At the interval laid down in the Service Schedule, disconnect the leads to A1 and A2 and measure the millivolt drop across the contacts. Fit a replacement if the value obtained exceeds 30 mV with the contacts carrying 15 amp. The contactor must also be rejected for an open-circuit coil.

Armature

31. The insulation resistance, measured at 500 V d.c. must equal or exceed 0.5 megohm. Attempt to improve an unacceptably low insulation resistance by blowing out brush dust from the overhangs with clean, dry, compressed air then drying the armature in a ventilated oven for four hours at 135 deg.C. Re-test and if still unsatisfactory, wash the armature liberally with white spirit using a stiff brush (immerse if convenient) then repeat the drying out process, extending the period to eight hours.

32. If the insulation resistance is improved to an acceptable value, varnish windings and lamination stacks with Epihard 480 varnish, mixed in the ratio of three parts by volume of 480/1 (Ref. No. 33B/1516) resin to one part of 480/2 accelerator (Ref. No. 33B/1517). Use a separate measure for each constituent and avoid contaminating one with the other.

33. If the surface of the commutator or sliprings is marked or excessively grooved, skim on a lathe just sufficiently to remove the damage, using a diamond tipped tool. Maintain the limits for dimensions listed in Leading Particulars. If the depth of undercutting of the commutator mica segments is less than 0.015 in. after skimming, re-cut to the dimensions specified. After skimming, or if the serviceability of the armature is suspect, a millivolt drop test must be performed between adjacent commutator bars with the armature suitably excited. All readings must be substantially equal, or the armature must be rejected.

34. When either commutator or slipring have been reduced to the minimum worn diameter, or if the armature is in any way electrically unsound, a new armature must be fitted. Check the commutation by measuring the shunt field current and adjusting the input (d.c.) brushgear to obtain the correct value. Instructions for setting the commutation are given in Testing, para. 76.

Field and magnet assembly

35. If the insulation resistance of the wound field is low, attempt to improve it by blowing out the brush dust and stoving the assembly complete with control box for twelve hours at a temperature not exceeding 60 deg.C. If this operation fails the machine must be returned to base.

RESTRICTED

Caution . . .

The insulation resistance must not be measured at more than 100V d.c. or certain components in the control box will be destroyed.

Covers

36. Change any cover which is damaged beyond repair. The procedures are obvious.

Carbon pile regulator

37. Because it is mounted externally, this regulator is fully accessible for adjustment or servicing without any dismantling of the control box. General instructions for servicing carbon pile regulators of similar type are to be found in A.P.4343B, Vol. 1, Sect. 1, Chap. 1.

DISMANTLING**Covers**

38. Refer to Fig. 2. Take off the front plate of the control box by loosening the two upper screws and unscrewing the lower ones, which are captive. Remove the top cover screws and lift off top cover.

39. Remove the terminal screws from TB1 to disconnect the leads to the end cover and transistor assembly then remove the screws holding the error detector block, collect the shield and move the block to one side to expose the screw securing the cable clamp for these leads. Take out this screw and collect the nut and washers, remove the stiff nuts holding the end cover assembly and pull this off, feeding the leads through the bottom of the control box.

40. Remove the bevelled retaining ring and take off the air outlet cover: take out the fixing screws for the output brushgear cover plates and slide these clear of the guide plate.

Brushes

41. Remove the screws holding the input (d.c.) and output (a.c.) brushes and lift out each brush, controlling the springs or triggers. Lower these gently into the brush holders when the brushes are clear.

Permanent magnet (P.M.) alternator

42. Disconnect the two leads to the ter-

minal block, take out the fixing screws and remove the stator end cover. Remove the special nut and tabwasher from the end of the armature shaft and take off magnet, magnet sleeve and stator assembly; collect the key. Slide off the magnet spacer and shims and keep together.

43. Store magnet in the stator, which will act as a keeper. Handle it with care and protect it from contamination by swarf and other metallic debris.

Armature and commutator end (C.E.)**Housing**

44. Unscrew the fan nut, pull off the fan and collect the Woodruff key. Remove the cover studs and tabwashers holding the C.E. housing then drift out the armature complete with the housing, using a pad to protect the end of the shaft. Separate the armature from the C.E. housing with a suitable arbor press.

45. Take out the fixing screws and washers and lift out the input (d.c.) brushgear assembly. Remove the retaining ring and collect the bearing dust cover; heat the housing to about 100 deg.C. and remove the bearing.

Note . . .

Ensure that the position of the brushgear is marked by a scribed line embracing the moulded mounting plate and the end housing so as to preserve the setting for optimum commutation.

Input (d.c.) brushgear

46. Prise out the insulating washers covering the brush holder fixing screws, unscrew and remove each brush holder.

Note . . .

It is only necessary to dismount a brush holder if adjustment of the spring tension is required.

Slipping end (S.E.) housing

47. Insert a long-bladed screwdriver into the field magnet assembly tunnel and remove the screw holding the cable loom support. Remove the S.E. housing securing bolts and separate the housing from the machine, feeding the leads through.

RESTRICTED

48. Remove the output (a.c.) brushgear assembly fixing screws, turn the brushgear assembly through 90 deg. and manoeuvre it from the housing. Take off the bearing retaining cap, heat the housing to about 100 deg.C. and remove the bearing.

Output (a.c.) brushgear

49. Remove the fixing nuts, washers and outer ceramic insulators from the fixing studs, take off the outer brush holder plates and repeat, marking each brush holder as it is removed to facilitate re-assembly.

Note . . .

It is only necessary to remove a brush holder if adjustment of the spring tension is necessary.

Contactors

50. To remove a faulty contactor, disconnect all the cables and collect the spacer from terminal A2 and the link from terminals A1 and B1. Unscrew the four captive fixing screws and lift out the contactor, as shown in Fig. 5.

CLEANING AND INSPECTION

51. Clean the exterior of the machine with a swab or stiff brush and blow away the dust from the control box, wound assemblies and brushgears with clean dry compressed air. In the case of heavy soiling, brush-on white spirit sparingly to loosen, then blow away and blot with clean rag. C.E. and S.E. housings can be washed in white spirit: leads and cables can be wiped with a rag moistened with white spirit.

52. Discard all brushes and tabwashers and any single coil spring washer which has become flattened. Scrutinize the exterior of the machine for damage and corrosion and the interior of the control box generally for signs of burring, perishing and any other visual indications of unserviceability: reject if present. Look for any insecurity amongst components and terminal connections not dismantled: correct if possible otherwise reject.

ASSEMBLING

Adjustment of brush forces

53. Refer to Fig. 7 shewing details of

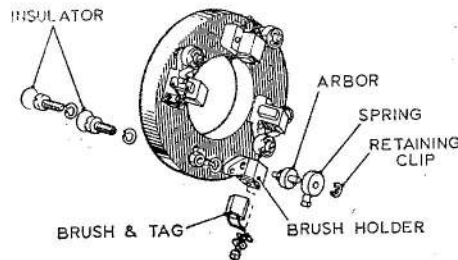

Fig. 7. Exploded view of input brushgear

the input (d.c.) brushgear. Unwind the spring on the faulty brush holder to release the tension and remove the arbor fixing nut and spring washer. Note the position of the square shank in the star-hole in the brush holder, then eject the arbor complete with spring, turn it one notch in the required direction (usually to increase force), and re-assemble to brush holder. Wind the free end of the spring back to the brush holder aperture to restore the tension and re-check the force. If the existing spring cannot be re-set within the limits shewn in the Leading Particulars, remove the circlip from the arbor, fit a new spring and set the force as described.

54. Assemble the brush holders to the mounting plate, secure with screws and spring washers and stick new insulators over the screw leads with Epihard 480 varnish.

55. Refer to Fig. 8 shewing details of the output (a.c.) brushgear. Remove the nut and spring washer securing the arbor of the faulty assembly to the brush holder.

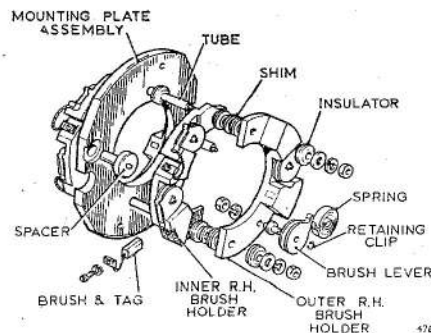

Fig. 8. Exploded view of output brushgear

RESTRICTED

Insert a short screwdriver into the spring slot then ease the square shank of the arbor clear of the star-shaped hole in the brush holder plate with the finger of one hand whilst holding the tension of the spring by means of the screwdriver; turn one notch in the required direction with the screwdriver then use it to re-insert the arbor and trigger assembly into the star hole. Secure with nut and spring washer and check force. Fit a new spring if the existing one will not re-set within limits.

56. Re-assemble each brush holder in turn to the mounting plate, fitting the insulators as shewn in the illustration and paying attention to the identification marks.

Slipring end (S.E.) housing

57. Heat the housing to about 100 deg.C., insert the bearing and secure it by means of the retaining cap, screws and spring washers. Manoeuvre the output brushgear into the housing, chamfered edge of the mounting plate downwards, rotate it into position and secure it with screws and spring washers.

58. Position the assembled housing in correct relationship to the partly assembled machine and feed the brushgear and permanent magnet alternator leads through to their respective situations as shewn in Fig. 9. Secure the cable support to the S.E. housing, inserting the screw and washer by way of the field and magnet assembly tunnel, then bolt the housing to the machine.

Commutator end housing and armature

59. Heat the housing to about 100 deg. C. and insert the bearing. Fit the brushgear to the housing, line-up the commutation positioning marks and secure with screws, plain and spring washers. Degrease the commutator with trichlorethylene or any approved degreasing agent then support the bearing inner race and press the armature home into the C.E. housing, using a suitable arbor press.

60. Stand the partly assembled machine on end, supported on the S.E. bearing inner race, under the arbor press then degrease the sliprings and lower the armature into the tunnel until the bearing is encountered. Line-up the end housing locating pin then force home the armature.

61. Stand the machine on its feet and secure the C.E. housing by means of the cover studs and tabwashers. Place the dust cover over the bearing and fit the retaining ring. Fit the Woodruff key to the armature shaft, push on the fan and secure it with the fan nut and washer.

Brushes

62. Position the d.c. field tags to line-up with the fixing holes in the input brush holders, then fit a new brush in each holder and secure with screws and spring washers, clamping a field tag between each brush holder and brush tag. Lift the brushes clear of the commutator and use the springs to latch them against the sides of the brush holder.

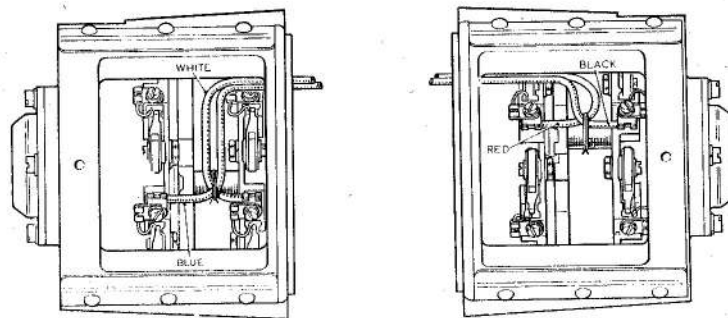

Fig. 9. Arrangement of connections to output brushgear

RESTRICTED

Note . . .

Hold all brush tags in an attitude which allows the pigtails a free run, whilst tightening the fixing screws and spring washers.

63. Insert two new brushes into each output brush holder and secure with screws and spring washers, clamping the lead tags between the brush holders and the brush tags, in the positions shewn in Fig. 9. Lift brushes clear of the sliprings and latch them against the side of the brush holders with the triggers.

Frequency regulator (P.M.) alternator

64. Assemble the shims and magnet spacer against the bearing at the S.E. and fit the Woodruff key to the shaft. Mount the stator housing assembly on the spigot on the S.E. housing with the leads at the top, then slide the magnet on to the magnet sleeve and carefully insert the assembly into the stator, locating the key in the keyway. Secure with the special nut and tabwasher, tightening to a torque load of 5 to 8 lb in. Fit the stator end cover, secure it with screws, plain and spring washers and make the connections to the terminal block, connecting both PM1 leads to one terminal by means of Nyloc nut and washer and both PM2 leads to the other.

Freedom of armature

65. Spin the armature by means of the fan and check that it runs smoothly and silently. If there is any signs of sluggishness settle the bearings by striking the side of the machine two or three times with a heavy soft-faced mallet.

66. Free all brushes from their position and lower them gently on to the commutator and sliprings. Dress the pigtails in smooth loops clear of any part of the frame and check that they can flow smoothly into the brush apertures. Perform the preliminary brush bedding operation at this stage, in accordance with the

procedure detailed in A.P.4343, Vol. 1, Sect. 1, Chap. 2.

Contactors

67. Position a replacement contactor so that the thinner terminal studs (coded X1 and X2) are at the rear and mount it on the platform on the control box floor by means of the four captive screws. Fit the spacer on terminal A2 and the link on the terminals A1 and B1 then re-make all connections in accordance with the coding, using nuts, spring and plain washers.

Covers

68. Fit the end cover and transistor assembly on to the cover studs and secure by means of stiff nuts and washers. Feed the leads through the aperture in the floor of the control box, secure the cable clamp to the side of the control box by means of the screw, washers and nut, and re-connect the tags to TB1. Line-up the error detector block, fit the shield and secure both with screws and washers. Re-fit the air inlet cover.

69. Slide the output brushgear cover plates into the guides and secure with screws and spring washers. Fit the air outlet cover and the retaining ring.

70. Fit the control box top cover and secure with screws and washers. Loosen the two front screws on this cover then assemble the front cover plate to the machine, clamping it behind the washers on these screws and securing it by means of the captive (lower) screws.

TESTING

General

71. Commutation setting applies only if a new armature has been fitted. The remaining tests are applicable each time a machine is serviced.

Test equipment

72. The following test equipment or suitable equivalents are required to perform the tests detailed below :—

Ref. No.	Description	Qty.
(1) 5G/564	Inverter tester	1
(2) 5QP/17447	Multimeter, Type 12889	1
(3) 5CW/6430	Single pole 5A switch	1
(4) 1H/96	Tension gauge, 0 - 2 lb	1
(5) 1H/59	Tension gauge, 50 - 250 gm.	1

RESTRICTED

Starting and brush bedding

73. Connect the machine input and output terminals to the appropriate terminals on the inverter tester and set the d.c. voltmeter range selector to 0-30, the d.c. ammeter to 0-50 and the a.c. voltmeter to 0-300: switch the a.c. voltmeter to phase A. Connect the switch between terminal 1 on the machine output terminal block (OTB) and the 30V d.c. +ve terminal on the inverter tester. Closing this switch will start the machine if the supply is on.

74. Adjust the input voltage to 28V d.c. start the machine on no-load and check that the output is a nominal 208V a.c. for each phase at a nominal frequency of 400 c.p.s. Use the machine trimmers P2 and R4 to obtain these settings if necessary.

75. To finally bed-in the brushes (refer to para. 66 for pre-bedding instructions) connect the machine to half load (balanced, 3 phase, 250 watts) on a 28V d.c. input. Trim to 208V and 400 c.p.s. as before if necessary and run continuously until the input (d.c.) brushes are in contact with the commutator over the full area of their faces and the output (a.c.) brushes have more than half their area in contact with the sliprings. The machine must be kept under observation at regular intervals and the voltage and frequency trimmed as necessary, especially during the early stages when any defects are likely to emerge. Blow away brush dust accumulation in both end housings with dry air, after bedding is complete.

Set commutation

76. If a new armature has been fitted, the position of the input brushgear may need adjusting to secure optimum commutation. To set up for this, detach the two metal braided CON A1 leads from the terminal on the contactor link and the metal braided/heavier gauge R5A lead from diverter resistor R5. Establish continuity between one of the CON A1 leads and the R5A lead; reconnect the other one to the link. Mark the identified lead ZZ (shunt field +ve), join it to the -ve terminal of the multimeter and supply a

short temporary return from the meter +ve terminal to the link terminal. Re-make the R5A connection to R5. Set the multimeter, which will monitor the shunt field current on the 0-5A range. Remove the end cover and transistor assembly and fold it to one side—still connected. Take off the fan and collect the fan key.

77. Run the machine on 28.5V d.c. input, no load and an output frequency of 400 c.p.s. (trim with P2 if necessary). Observe the shunt field current then stop the machine and loosen the four fixing screws just sufficiently to permit the input brushgear to be rotated. Set the commutation by adjusting the position of the input brushgear to secure a shunt field current of 3.8-4.0A whilst maintaining the frequency at 400 c.p.s. by means of frequency trimmer P2.

Caution . . .

Allow the machine to come to rest before adjusting brushgear and always tighten screws before starting up. Beware of the exposed end of the armature shaft.

78. Mark the commutation position on the edge of the brushgear mounting plate and the end housing, deleting traces of any previous marking. Refit the fan and key and the end cover and transistor assembly. Take the shunt field meter out of circuit, re-make CON A1 connection to the contactor link and fit the control box covers.

Performance test

79. Set the input voltage to 25V d.c. run the machine on a 3 phase balanced load of 500 watts and trim the frequency and voltage to exactly 400 c.p.s. and 208V r.m.s. line-to-line, using P2 and R4. Raise the input to 28V d.c. and run the machine for half an hour; all covers fitted. At the end of this time vary the running conditions as follows:—

- (1) Start on no-load at 28.5V d.c. input.
- (2) Adjust input to 25V d.c. and introduce a 500 watt load, unity power factor.

Throughout these conditions the machine

RESTRICTED

must perform within the following limits:—

Output voltage 205-211V r.m.s. with a line-to-line deviation not exceeding 2.5V r.m.s.
Frequency 396-404 c.p.s.
Input current 50 amp. maximum.

If the machine exceeds any limit re-trim voltage and/or frequency and repeat the performance test. If a voltage deviation which is outside the range of trimmer R4 is encountered, attempt to correct this by adjusting the voltage regulator as de-

scribed in A.P.4343B, Vol. 1, Sect. 1, Chap. 1.

80. If a new armature has been fitted the commutation must be checked visually with the machine running on load at its working temperature. Immediately after the successful completion of Performance test (2), take off the end cover and transistor assembly and turn it to one side clear of the fan (do not disconnect). Start the machine on the same input and load and observe any sparking at the commutator. If sparking is of a yellow flash nature the commutation must be re-set and all tests repeated.

RESTRICTED

Appendix A
STANDARD SERVICEABILITY TEST
FOR
ROTARY INVERTER, TYPE 117

Introduction

1. Apply the tests detailed in this Appendix before a machine is put into service, or if at any time its serviceability becomes suspect.

TEST EQUIPMENT

2. The following test equipment, or suitable equivalents, will be required to perform the tests detailed in this Appendix:—

- (1) Inverter tester, Ref. No. 5G/564.
- (2) 5 amp single pole switch, Ref. No. 5CW/6430.

TEST PROCEDURE

Functional test

3. Connect the machine input and output terminals to the appropriate terminals on the inverter tester and connect the switch between terminal 1 on the machine OTB and the 30V d.c. +ve terminal on the inverter tester. Closing this switch will start the machine if the supply is on.

4. Remove the end cover and transistor assembly and turn it to one side, clear of the fan without disconnecting it. Adjust the input to 28.5V d.c. then start the machine on no-load and check that:—

- (a) The output voltage is 205-211V r.m.s. with a line-to-line deviation not exceeding 2.5V r.m.s.
- (b) The frequency falls within the limits 396-404 c.p.s.
- (c) The input current does not exceed 18 amp.

If these requirements are met perform two more starts. They must be free from excessive sparking and the control system should latch-on without noticeable delay.

5. Adjust the input to 22V d.c. introduce a load of 500 watts and repeat the previous tests. The input current must not exceed 50 amp.

6. Re-fit the end cover and transistor assembly.

RESTRICTED

This file was downloaded
from the RTFM Library.

Link: www.scottbouch.com/rtfm

Please see site for usage terms,
and more aircraft documents.

