

Chapter 5

ROTARY INVERTER, TYPE RC8 SERIES

LIST OF CONTENTS

	Para.		Para.
Introduction	1	Bearings	7
Description	2	Brush gear	8
Servicing	6	Testing	10

LIST OF ILLUSTRATIONS

	Fig.		Fig.
Rotary inverter, Type RC8A	1	Dismantled view of inverter	3
Sectional view of inverter	2	Circuit diagram	4

LIST OF APPENDICES

Rotary inverter, Type RC8B	App.	1
-----------------------------------	------	---

LEADING PARTICULARS

Rotary inverter, Type RC8A (Rotax S2701/1)		Ref. No. SUB/4795
Input	19.5 amp., 27 volts d.c.	
Output	1.81 amp., 115 volts, a.c., 3-phase, 400 c/s	
Speed	8,000 r.p.m.	
Brushes, grade F2C—		
Input		Ref. No. SUB/6091
Output		Ref. No. SUB/6092
or Brushes, grade KCEG11—		
Input		Ref. No. SUB/6093
Output		Ref. No. SUB/6094
Brush spring pressure—		
Input		7.5 to 9 oz.
Output		1.7 to 2.1 oz.
◀ Rotor resistance		0.68 ohms per phase
Field resistance values (at 20 deg. C.)—		
Shunt		15.0 ohms
Series		0.0155 ohms
Commutator diameter (new)		1.942 in.
Commutator diameter (minimum permissible)		1.780 in.
Slip-ring diameter (new)		1.250 in.
Slip-ring diameter (minimum permissible)		1.230 in. ▶
Fixing centres		4.5 in. × 2 in.
Weight		13 lb. 5 oz.

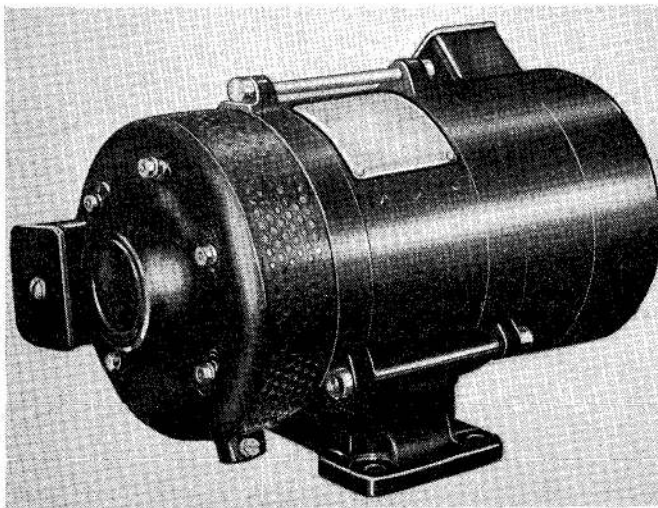

Fig. 1. Rotary inverter, Type RC8A

RESTRICTED

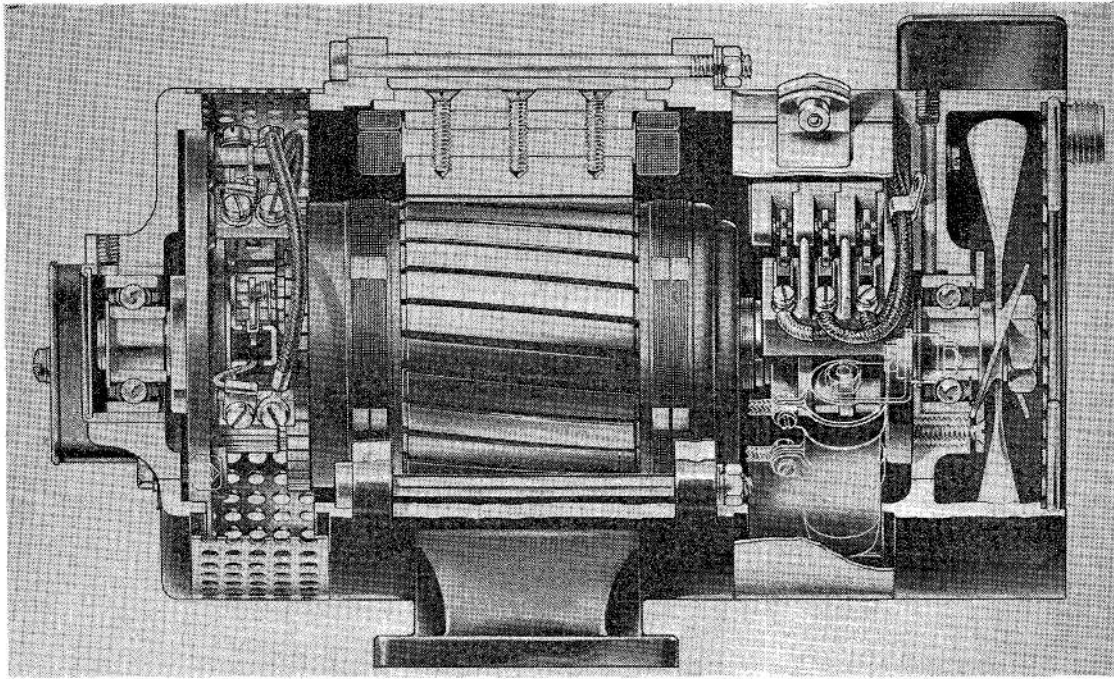

Fig. 2. Sectional view of inverter

Introduction

1. The rotary inverter, Type RCSA (*fig. 1*), is a six-pole, compound-wound machine, primarily intended to supply three-phase alternating current for flight instruments. With an input of 27 volts d.c., the machine gives an output of 115 volts, 400 c/s, 3-phase a.c., 360 VA, 0.8 power factor. It is suitable for continuous operation at altitudes up to 35,000 ft.; above this height, however, there will be slightly reduced output and a tendency to overheat.

DESCRIPTION

2. A sectional view of the inverter is given in *fig. 2*, and a dismantled view in *fig. 3*. Each pole piece is held in position in the bore of the yoke by three countersunk-headed screws. Both shunt and series field windings are carried on the pole pieces, the latter being fitted next to the yoke. A variable resistance connected in series with the shunt field, and located under the output end housing, enables the speed to be adjusted to give an output frequency of 400 c/s.

3. Both input and output windings are carried in common slots in the rotor and are secured by wire banding. The shaft rotates in ball bearings, one being located in the

slip-ring end frame and the other in the commutator end frame. The end frames are spigoted to the yoke and held in position by three through-bolts and hexagon nuts.

4. A plain cover band at the output end allows access to the slip-rings and brushes, a perforated band at the opposite end of the machine giving access to the four L.T. brushes and the commutator. The cooling fan is accessible through a removable cover-plate at the a.c. output end of the machine, and is held in position by a hexagon nut and circlip. Brush pressure is maintained by spring-loaded brush fingers, and the d.c. brush position adjusted by loosening the six hexagonal headed nuts securing the insulating disc on which the brush boxes are mounted.

5. A four-hole fixing bracket bolted to the underside of the yoke enables the machine to be mounted in any desired position.

SERVICING

6. General information on the servicing of inverters is given in A.P.4343, Vol. 1, Sect. 8.

Bearings

7. The bearings are lubricated with grease XG-271 (*Ref. No. 34B/9100510*) during

RESTRICTED

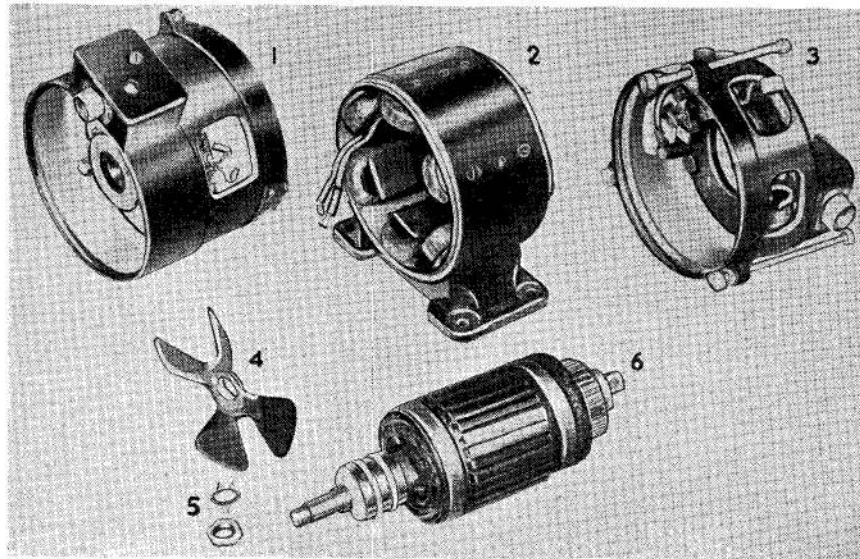

Fig. 3. Dismantled view of inverter

manufacture, and should not require attention between major servicing periods.

Brush gear

8. Brushes should be renewed before the minimum permissible length is reached; for the a.c. brushes the minimum length is 0.300 in., and for the d.c. brushes 0.375 in. Details of the brush grade and correct spring pressure are given under Leading Particulars.

9. Brush spring pressure should be measured with a suitable tension gauge (such as Stores

Ref. 1H/86, 100-500 gm. for the d.c. side, and Stores Ref. 1H/58, 10-80 gm. for the a.c. side). Measurements should be taken as the eye of the spring leaves the top of the brush, care being taken to ensure no movement of the brush itself.

Testing

10. Before subjecting the inverter to any tests, check that the a.c. brushes are connected to external terminals of the same colour marking. Operate the inverter to ensure that the phase sequence is red, blue, green.

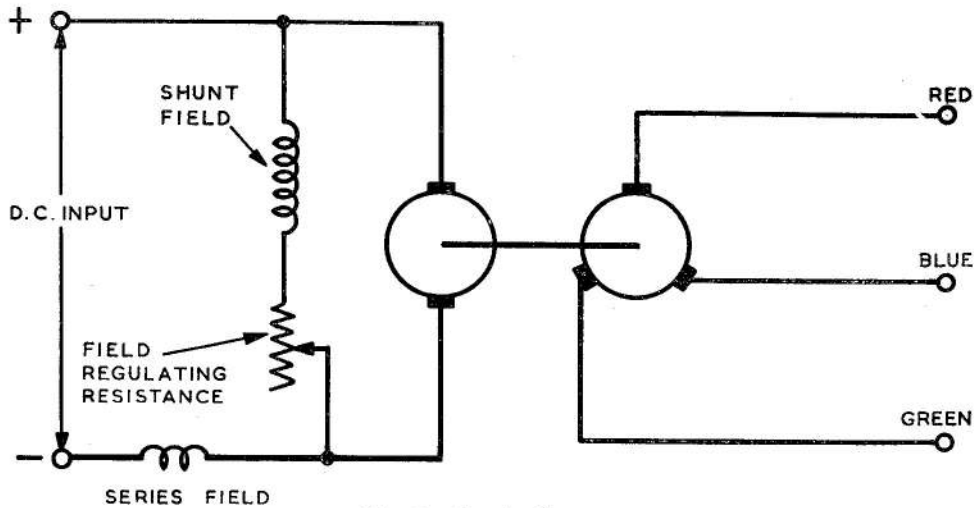

Fig. 4. Circuit diagram

RESTRICTED

(A.L.I, Sep. 57)

11. Run the machine continuously for a period of $1\frac{1}{2}$ hours with an input voltage of 27 volts d.c. and an output of 360 VA, 288 watts, 0.8 power factor lagging. It is essential that during this run, the load across each pair of lines should be equal (both resistive and reactive), to give equal currents in each line.

12. At the beginning of each run, set the d.c. brushes to give sparkless commutation as judged visually. The speed should be set by means of the built-in regulating resistance. While still hot after this run, the inverter must be subjected to the following tests.

13. With an input of 27 volts d.c., the output current should be set to 1.81 amp. in each line, with a power factor of 0.8 lagging. The output voltage must now lie between 110 and 120 volts, and the speed between 7,680 r.p.m. and 8,320 r.p.m. If necessary, adjust the speed by means of the shunt field resistor.

14. With 27 volts d.c. input, set the load to give a balanced output of 90 VA, 72 watts, at 0.8 power factor lagging. With this load, the output voltage must not exceed 112 per cent of the voltage delivered at 360 VA, 0.8 power factor (*para.* 13). The speed must not exceed 108 per cent of its value when delivering 360 VA at 0.8 power factor.

RESTRICTED

Appendix 1

ROTARY INVERTER, TYPE RC8B

LEADING PARTICULARS

Rotary inverter, Type RC8B	Ref. No. 5UB/6854
Input—									
Voltage	27V d.c.
Current	19.5 amp.
Output—									
Voltage	115V, 3-phase a.c.
Frequency	400 c/s
Power (rated)	288W, 0.8 power factor (lagging)
Phase sequence	Red, blue, green
Input brushes—									
Brush grade	F2C (Ref. No. 5UB/6091) or KCEG11 (Ref. No. 5UB/6093)
Spring pressure	7.5 to 9 oz. (213 to 255 gm.)
Output brushes—									
Brush grade	F2C (Ref. No. 5UB/6092) or KCEG11 (Ref. No. 5UB/6094)
Spring pressure	1.7 to 2.1 oz. (48.2 to 59.5 gm.)
Speed	8,000 r.p.m.
Rotor resistance	0.68 ohms per phase
Field resistance at 20 deg. C—									
Shunt	3.0 to 3.7 ohms
Series	0.0155 ohms
Commutator diameter (new)	1.942 in.
Commutator diameter (minimum permissible)	1.780 in.
Slip ring diameter (new)	1.250 in.
Slip ring diameter (minimum permissible)	1.230 in.
Fixing centres	4.5 in. × 2 in.
Weight	13 lb. 5 oz.

RESTRICTED

1. The rotary inverter, Type RC8B is a modified version of the RC8A inverter described in the main chapter. The modification was introduced to reduce output frequency variation, which in the RC8A is caused by the changes of shunt field resistance due to temperature changes within the machines.

2. In the Type RC8B inverter, the ratio of ballast to shunt field resistance has been increased. This has been achieved by reconnecting the shunt field coil in series parallel, and replacing the existing internal shunt field ballast resistance by a larger one mounted externally to the machine. A circuit diagram is given in fig. 1.

Testing

Before installation

3. (1) With the d.c. brushes lifted, check that the shunt field resistance, measured between the positive brush anchor post and the field anchor post, lies between 3.0 and 3.7 ohms.
- (2) With the d.c. brushes replaced, check for continuity between the ends of the two Unifersilmet 14 input cables.
- (3) Check that the insulation resistance measured between the positive brush anchor post and the frame is not less than 2 megohms.
- (4) Check for continuity between the metal braid and the four Unifersilmet cables from the machine input terminal box and the frame.
- (5) Connect a suitable 5-ohm resistance between the two Unifersilmet 22 cables from the input terminal block. The

machine should then be run on a suitable 27-volt d.c. supply with a load of 290 watts at unity power factor, with the brushes in the mid-position. At the end of $1\frac{1}{2}$ hours, the brushes should be set to the mean non-spark position. The output voltage throughout the run should be between 110 and 120 volts and the frequency between 300 and 450 c/s.

After installation

4. The following procedure should be adopted after installation in aircraft, with the inverter connected to an external ballast and regulating resistor, to obtain an output frequency between 380 and 420 c/s during flight. It is assumed that the pre-installation tests (para. 3) have been satisfactory.

- (1) Remove the cooling air connections from the inverter.
- (2) Set the shunt field ballast and regulating resistor to approximately 6 ohms.
- (3) Check that the phase sequence of the machine is correct (i.e. red, blue, green) and then run the inverter against the normal No. 1 inverter load (i.e. MRG and other instruments) for 30 minutes, with a bus bar set at 28 volts.
- (4) Measure the bay temperature.
- (5) Adjust the output frequency of the machine by means of the shunt field ballast and regulating resistor to the value indicated by Curve A in fig. 2 for the bay temperature measured in (4) above.

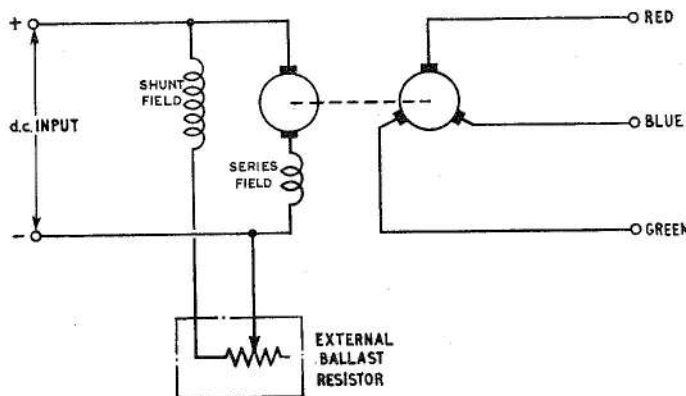

Fig. 1. Circuit diagram

RESTRICTED

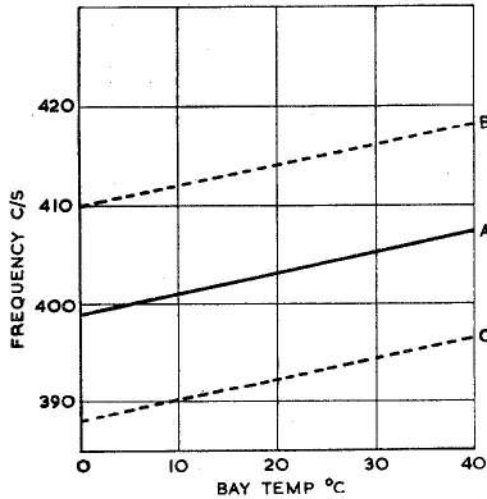

Fig. 2. Frequency/bay temperature characteristics

- (6) Increase the bus bar voltage to 29 volts, and then decrease to 27 volts. In both instances the output frequency, assuming

the same bay temperature, should be within the limits given by Curves B and C in fig. 2, and the output voltage should be within the limits of 105 and 122 volts.

- (7) If the frequency is outside either of the limits given in sub-para. (6), the shunt field ballast and regulating resistor should be adjusted to ensure that the variation of frequency lies within these limits.
- (8) If the voltage is outside the limits given in sub-para. (6), the inverter should be checked for correct brush position (*para. 3, sub-para. (5)*).

Note . . .

During the above tests, both inverters should be running. This will allow one inverter to act as a stand-by and to take over the instrument loads while the other has been stopped for any necessary adjustment to the shunt field ballast and regulating resistance. The M R G will therefore be supplied continuously.

RESTRICTED

This file was downloaded
from the RTFM Library.
Link: www.scottbouch.com/rtfm
Please see site for usage terms,
and more aircraft documents.

